



# KE8980MR

4K Quad-Display KVM over IP  
Multi-View Receiver  
User Manual

## Compliance Statements

### FEDERAL COMMUNICATIONS COMMISSION INTERFERENCE STATEMENT

This equipment has been tested and found to comply with the limits for a Class A digital device, pursuant to Part 15 of the FCC Rules. These limits are designed to provide reasonable protection against harmful interference when the equipment is operated in a commercial environment. This equipment generates, uses, and can radiate radio frequency energy and, if not installed and used in accordance with the instruction manual, may cause harmful interference to radio communications. Operation of this equipment in a residential area is likely to cause harmful interference in which case the user will be required to correct the interference at his own expense.

The device complies with Part 15 of the FCC Rules. Operation is subject to the following two conditions: (1) this device may not cause harmful interference, and (2) this device must accept any interference received, including interference that may cause undesired operation.

#### FCC Caution

Any changes or modifications not expressly approved by the party responsible for compliance could void the user's authority to operate this equipment.

#### Warning

Operation of this equipment in a residential environment could cause radio interference.

#### Achtung

Der Gebrauch dieses Geräts in Wohnumgebung kann Funkstörungen verursachen.



#### KCC Statement

유선 제품용 / A 급 기기 (업무용 방송 통신 기기)  
 이 기기는 업무용 (A 급) 전자파적합기기로서 판매자 또는 사용자는 이  
 점을 주의하시기 바라며, 가정 외의 지역에서 사용하는 것을 목적으로  
 합니다.

### **Industry Canada Statement**

This Class A digital apparatus complies with Canadian ICES-003.

## **CAN ICES-003 (A) / NMB-003 (A)**

### **HDMI Trademark Statement**

The terms HDMI, HDMI High-Definition Multimedia Interface, HDMI trade dress and the HDMI Logos are trademarks or registered trademarks of HDMI Licensing Administrator, Inc.



### **RoHS**

This product is RoHS compliant.

---

## User Information

---

### Online Registration

Be sure to register your product at our online support center:

---

International	<a href="http://eservice.aten.com">http://eservice.aten.com</a>
---------------	---

---

### Telephone Support

For telephone support, call this number:

---

International	886-2-8692-6959
China	86-400-810-0-810
Japan	81-3-5615-5811
Korea	82-2-467-6789
North America	1-888-999-ATEN ext 4988 1-949-428-1111

---

### User Notice

All information, documentation, and specifications contained in this manual are subject to change without prior notification by the manufacturer. The manufacturer makes no representations or warranties, either expressed or implied, with respect to the contents hereof and specifically disclaims any warranties as to merchantability or fitness for any particular purpose. Any of the manufacturer's software described in this manual is sold or licensed *as is*. Should the programs prove defective following their purchase, the buyer (and not the manufacturer, its distributor, or its dealer), assumes the entire cost of all necessary servicing, repair and any incidental or consequential damages resulting from any defect in the software.

The manufacturer of this system is not responsible for any radio and/or TV interference caused by unauthorized modifications to this device. It is the responsibility of the user to correct such interference.

The manufacturer is not responsible for any damage incurred in the operation of this system if the correct operational voltage setting was not selected prior to operation. **PLEASE VERIFY THAT THE VOLTAGE SETTING IS CORRECT BEFORE USE.**

## Product Information

---

For information about all ATEN products and how they can help you connect without limits, visit ATEN on the Web or contact an ATEN Authorized Reseller. Visit ATEN on the Web for a list of locations and telephone numbers:

International	<a href="http://www.aten.com">http://www.aten.com</a>
North America	<a href="http://www.aten-usa.com">http://www.aten-usa.com</a>

## **Package Contents**

---

Check to make sure that all the components are in working order. If you encounter any problem, please contact your dealer.

The KE8980MR package consists of:

- 1 KE8980MR 4K Quad-Display KVM over IP Multi-View Receiver
- 1 power adapter and power cord
- 1 user instructions

# Contents

---

Compliance Statements . . . . .	ii
User Information . . . . .	iv
Online Registration . . . . .	iv
Telephone Support . . . . .	iv
User Notice . . . . .	iv
Product Information . . . . .	v
Package Contents . . . . .	vi
Contents . . . . .	vii
About This Manual . . . . .	x
Conventions . . . . .	xi
<b>Chapter 1.Introduction</b>	
Overview . . . . .	1
Features . . . . .	2
Advanced Features* . . . . .	2
Hardware. . . . .	3
Management . . . . .	3
Security . . . . .	4
Virtual Media . . . . .	4
Requirements . . . . .	5
Operating System . . . . .	5
Console . . . . .	5
Cables . . . . .	5
Components . . . . .	6
<b>Chapter 2.Hardware Setup</b>	
KE8980MR Installation . . . . .	10
Installation Diagram . . . . .	11
Things to Note . . . . .	12
Network Configuration . . . . .	13
Exit OSD . . . . .	14
Default IP Addresses . . . . .	14
KE I/O Ports . . . . .	15
LED Display . . . . .	16
CCKM KVM over IP Matrix Manager . . . . .	16
<b>Chapter 3.OSD Operation</b>	
Overview . . . . .	17
Invoking the OSD . . . . .	17
Touch Screen Calibration . . . . .	17
OSD Interface . . . . .	18
User Preference Tab . . . . .	20
Receiver Tab . . . . .	21
System Settings . . . . .	21
Device Information . . . . .	22

Shutdown & Reboot	23
User Sta. Password	24
Properties Settings	25
General	26
RS-232 Settings	27
Properties	28
Manage Address	29
USB Mode	30
Network	32
Terminal Tab	33
About Tab	34
OSD Matrix Mode	35
Toolbar	35
Operation Mode Toolbar	37
Connection List	39
Multi-view Mode List	39
Operation Mode List	40
Array Mode	40
Push Content	42
Pull Content	43

## **Chapter 4. Firmware Upgrade Utility**

Preparation	45
Starting the Upgrade	46
Upgrade Succeeded	48
Firmware Upgrade Recovery	49

## **Appendix**

Safety Instructions	51
General	51
Rack Mount	53
Technical Support	54
International	54
North America	54
Specifications	55
KE8980MR	55
IP Installer	56
RS-232 Pin Assignments	57
Transmitter Front RS-232 Port	57
Keys to Network Performance	58
Build a Network Diagram	58
Other Factors	58
Choose a High Performance Switch	60
Layer 2 or Layer 3 Switches	60
Considerations	60
Number of ports	60
Stackable verse Standalone	60

What Stackable Switches Can do: .....	61
Switch Specifications. ....	61
Configuring Switches and KE Devices .....	62
KE transmitter Settings: .....	62
Recommended Network Switches .....	62
Additional Mouse Synchronization Procedures .....	63
Windows: .....	63
Sun / Linux .....	64
Virtual Media Support .....	65
WinClient ActiveX Viewer / WinClient AP .....	65
Java Applet Viewer / Java Client AP .....	65
Setup CCKM Server IP address on Windows .....	66
ATEN Warranty Policy .....	67

## About This Manual

---

This manual is provided to help you get the most out of your KVM over IP Matrix System. It covers all aspects of the device and system, including installation, configuration, and operation.

The KVM over IP Extender models covered in this user manuals are:

Models	Product Names
KE8980MR	4K Quad-Display KVM over IP Multi-View Receiver

An overview of the information found in the manual is provided below.

**Chapter 1, Introduction**, introduces you to the KVM over IP Matrix System, its purpose, features, and benefits, with its front and back panel components described.

**Chapter 2, Hardware Setup**, provides step-by-step instructions for setting up your installation, and explains some basic operation procedures.

**Chapter 3, OSD Operation**, explains the fundamental concepts involved in operating the KE8980MR, and provides a complete description of the On Screen Displays (OSDs) and the functions contained.

**Chapter 4, Firmware Upgrade Utility**, explains how to download and use the Firmware Upgrade Utility for upgrading the firmware of the devices connected.

**Appendix**, provides the technical and troubleshooting information of KE devices at the end of the manual.

---

### Note:

- ◆ Read this manual thoroughly and follow the installation and operation procedures carefully to prevent any damage to the unit or connected devices.
  - ◆ The product may be updated, with features and functions added, improved or removed since the release of this manual. For an up-to-date user manual, visit <http://www.aten.com/global/en/>
-

## **Conventions**

This manual uses the following conventions:

- |   |  |
|---|--|
| Monospaced  | Indicates text that you should key in.   |
| [ ]   | Indicates keys you should press. For example, [Enter] means to press the <b>Enter</b> key. If keys need to be chorded, they appear together in the same bracket with a plus sign between them: [Ctrl+Alt]. |
| 1.  | Numbered lists represent procedures with sequential steps.   |
| ◆   | Bullet lists provide information, but do not involve sequential steps.   |
| >   | Indicates selecting consecutive options (such as on a menu or dialog box). For example, Start > Run means to open the <i>Start</i> menu, and then select <i>Run</i> .                                      |
|  | Indicates critical information.  |

This Page Intentionally Left Blank

# Chapter 1

## Introduction

### Overview

---

The ATEN KE8980MR is a high-performance KVM over IP Multi-View receiver specifically engineered to empower operators in demanding, mission-critical control room environments. It supports quad-display output (2 HDMI and 2 DisplayPort), each capable of 4096 x 2160 @ 60Hz, providing an expansive and detailed operational view.

To maximize operational agility, the KE8980MR features two powerful modes tailored for mission-critical workflows. In Multi-view mode, it can display and control up to 16 video sources across up to 4 screens simultaneously, using flexible layouts, optimizing situational awareness and workflow efficiency. In Operation mode, it delivers ultra-low latency control with real-time Panel Array monitoring, instant one-click Push and Pull content sharing, and flexible source access through a Virtual Transmitter that streams video, audio, USB, and serial independently.

Seamlessly bridging physical and virtual resources, the KE8980MR offers native support for RDP and VNC protocols. This allows for direct, hardware-free access to virtual machines hosted on VMware®, Microsoft®, and Citrix™ platforms, alongside flexible switching to traditional KE Transmitters. The system's ultra-low latency operation ensures real-time interaction and immediate visual feedback, which is paramount for critical decision-making. Furthermore, its operation mode enables the monitoring of up to 108 screens, offering extensive scalability for large-scale operations.

The KE8980MR integrates seamlessly with ATEN's KE/KX transmitter series and the KVM over IP Matrix Manager (CCKM), offering flexible deployment options including point-to-point, point-to-multipoint, and multipoint-to-multipoint configurations. It also supports operator session recording when paired with ATEN's CCVSR (Control Center Video Session Recording) system, capturing a comprehensive record of user activity.

The KE8980MR is the ideal solution for extending high-resolution KVM control from multiple sources over IP across significant distances. The KE8980MR delivers seamless connectivity and centralized management, making it an indispensable solution for mission-critical control centers, collaborative conference rooms, and large-scale digital signage networks with multi-monitor configurations.

## Features

---

### **Advanced Features\***

- ◆ Provides versatile viewing and control modes: Multi-view mode and Operation mode

For Multi-view mode:

- ◆ Multi-view console controls up to 16 video sources on one screen with display modes
- ◆ Workspace: Allows saving multiple configuration profiles and switching screen layouts and connection states across four displays via hotkeys
- ◆ Connection List Panel: Includes source preview functionality and supports intuitive drag-and-drop to assign sources freely

For Operation mode:

- ◆ Features ultra-low latency operation, enabling simultaneous monitoring of up to 108 screens
- ◆ "Push" and "Pull" — shares content instantly to / from a single Rx or video wall by just one click
- ◆ Virtual transmitter — independently streams video, audio, USB, and serial sources from different Tx
- ◆ Virtual Machine connectivity: VMware®, Microsoft®, and Citrix™ by using RDP and VNC
- ◆ Easily switching to any Virtual Machine or KE Transmitter
- ◆ Boundless Switching MX — allowing real-time switching between systems simply by moving the mouse freely across displays and windows
- ◆ Flexible connections — allows multiple extender and matrix connections for multi-display installations
- ◆ Advanced Scheduling — improves efficiency and saves costs by allowing media playback to be set based on time and date
- ◆ Internal and external authentication support — supports LDAP, Active Directory, RADIUS and TACACS+ external authentications
- ◆ Advanced User Authorization Settings — administrators can set four access modes of permissions on Tx devices for collaboration or to avoid interference among users
- ◆ Configurable user and group permissions for access and control of KVM over IP extenders

- ◆ Rx access control — users at the Tx local console can enable / disable Rx access by simply pressing a control button

---

**Note:** These advanced functions are supported when the KE transmitters are paired with KE receivers and managed by CCKM.

---

## **Hardware**

- ◆ Features a purpose-designed architecture that combines high performance with energy efficiency — delivering advanced functionality while minimizing power usage
- ◆ Optimized power-performance balance — providing enterprise-grade functionality with reduced energy demands
- ◆ The housing meets IEC 60945 standards for maritime control room use and has passed environmental tests
- ◆ Supports Quad-Display Output — 2 HDMI and 2 DisplayPort outputs, each resolution up to 4096 x 2160 @ 60Hz
- ◆ Network failover — 2 RJ-45 ports for network failover to ensure constant availability for mission-critical applications
- ◆ DisplayPort 1.2 compliant
- ◆ High speed USB Storage Transmission support
- ◆ Auto-MDIX — automatically detects cable type
- ◆ Built-in 8KV/15KV ESD protection and 1KV surge protection

## **Management**

- ◆ Centralized management software — KVM over IP Matrix Manager (CCKM) allows users to easily administrator all KE devices with an intuitive web-based GUI
- ◆ Supports recording of remotely-accessed computer operations using CCVSR
- ◆ OSD (On Screen Display) on the Receiver configures both units
- ◆ EDID Expert™ — selects optimum EDID settings for smooth power-up and highest quality display
- ◆ Four selectable access modes for multiple simultaneous access (Exclusive/Occupy/Share/View only mode) – administrators can select access modes of permissions on Tx devices to boost collaboration or to avoid interference among users
- ◆ RS-232 serial port — allow users to connect to a serial terminal for TextMenu, or serial devices such as touch screens and barcode scanners

- ◆ Supports Hotkey Commands
- ◆ Video Compression Level — allow users to increase / decrease the video quality to adjust for appropriate network bandwidth
- ◆ Compatible with all KE devices

## **Security**

- ◆ Dedicated LAN port for KE direct connections — can be isolated from the corporate network
- ◆ Supports industry standard Transport Layer Security (TLS) protocol

## **Virtual Media**

- ◆ USB storage transmission mode enhances data transmission performance, ideally for file transfers, OS patching, software installations and diagnostic testing
- ◆ Supports USB 2.0 DVD / CD drives, USB mass storage devices, PC hard drives and ISO images
- ◆ Supports smart card / CAC reader

## Requirements

---

### Operating System

KE8980MR is compatible with the following operating systems:

OS		Versions
Windows	32-bit	XP / 7 / 8
	64-bit	XP / 7 / 8 / 8.1 / 10 / Server 2008 R2 / Server 2012 / Server 2016 / Server 2019
Linux		<ul style="list-style-type: none"> <li>◆ CentOS</li> <li>◆ Ubuntu</li> <li>◆ openSUSE</li> <li>◆ Red Hat</li> </ul>

- ◆ Mac OS
- ◆ Oracle Solaris

### Console

- ◆ Two DisplayPort compatible monitor capable of the highest possible resolution
- ◆ Two HDMI compatible monitor capable of the highest possible resolution
- ◆ A USB mouse
- ◆ A USB keyboard
- ◆ A headphone

### Cables

- ◆ For optimal signal integrity and to simplify the setup, we strongly recommend that you only use the high quality custom USB KVM Cable.

## Components

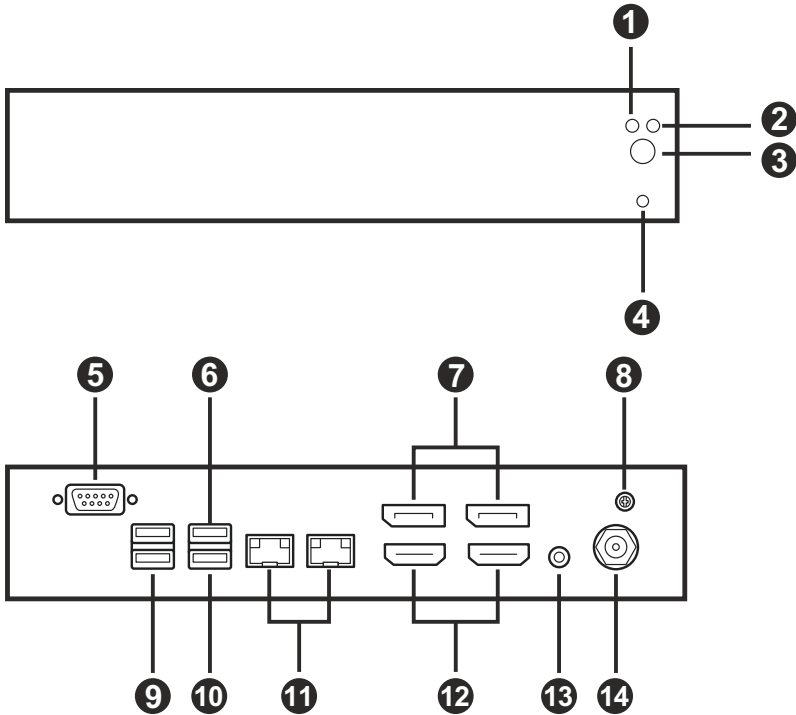

No.	Component	Description
1	storage LED	Lights orange to indicate the unit is turned on.
2	power LED	Lights blue to indicate the unit is turned on.
3	power button	Press to power on the unit.

No.	Component	Description
4	reset button	<p>This button must be pushed with a thin object, such as the end of a paper clip.</p> <ul style="list-style-type: none"> <li>◆ Press and release to reboot the device.</li> <li>◆ Power off, hold reset then power on the device while pressing reset to recover from a firmware upgrade failure.</li> <li>◆ Press and hold it in for more than three seconds resets the unit back to its factory default settings*.</li> </ul> <p>The Reset to Factory Default function resets everything but the login information (username/ password) to the factory default settings. To reset the login information, refer to <i>RS-232 Pin Assignments</i> on page 57.</p>
5	RS-232 serial port	This RS-232 serial port is for connecting to the computer for serial control.
6	USB Type-A port (keyboard)	<p>The unit's USB keyboard plugs into this port.</p> <p><b>Note:</b> When using a keyboard or mouse with special functions, see <i>USB Mode</i>, page 108.</p>
7	DisplayPort output port	The cables from the local DisplayPort monitors plug in here.
8	grounding terminal	The wire used to ground the unit connects here.
9	USB Type-A ports (peripheral)	<p>Use this port for virtual media or a USB peripheral device.</p> <p><b>Note:</b></p> <ol style="list-style-type: none"> <li>1. When using a USB disk plugged into this port, see <i>USB Mode</i>, page 108.</li> <li>2. This USB port does not support isochronous endpoints, therefore USB peripherals that stream audio or video data, such as speakers or webcams, will not work.</li> </ol>
10	USB Type-A port (mouse)	<p>The unit's USB mouse plugs into this port.</p> <p><b>Note:</b> When using a keyboard or mouse with special functions, see <i>USB Mode</i>, page 108.</p>
11	RJ-45 ports (LAN 1 / LAN 2)	The cables that connect the unit to the LAN plugs in here.
12	HDMI output port	The cables from the local HDMI monitors plug in here.
13	audio port	This mini stereo port is for headphone.
14	power jack	The cable from the DC power adapter connects here.

This Page Intentionally Left Blank

## Chapter 2

# Hardware Setup



1. Important safety information regard the placement of this device is found on. Please review it before proceeding.
2. Make sure that the power of all devices to be connected is turned off. You must unplug the power of any computers with Keyboard Power-on function.
3. Please operate the device with caution when under high environmental temperatures, as the surface of the device may become overheated under such conditions. For instance, the surface temperature of the device may reach 70 °C (158 °F) or higher when the environmental temperature reaches close to 50 °C 122 °F.

## KE8980MR Installation

---

Make sure that all equipment is powered off. Refer to the installation diagrams on the next page and do the following:

1. Use a grounding wire to ground the unit by connecting one end to the grounding terminal and the other end to a suitable grounded object.

---

**Note:** Do not omit this step. Proper grounding helps prevent damage to the unit from power surges or static electricity.

---

2. Connect the unit's DisplayPort and HDMI output ports to two DisplayPort and two HDMI monitors.
3. Connect the unit's audio port to a headphone.
4. Connect the unit's USB Type-A ports (keyboard / mouse / peripheral) to a USB keyboard, a USB mouse, and up to two USB flash drives.
5. Connect the unit's RS-232 serial port to a serial console device.
6. The KE8980MR is equipped with two RJ-45 ports. For extending control from an ATEN KE transmitter to a KE8980MR, it can be established using Cat 5e/6/6a cables through one of the following methods.
  - ◆ For high bandwidth, connect the unit's RJ-45 port (LAN 1) with KE6940AiT (example) to the same network via Cat 5e/6/6a cable.
  - ◆ For low bandwidth, connect the unit's RJ-45 (LAN 2) with KE6940AiT (example) to the same network via Cat 5e/6/6a cable.

---

**Note:** All the KE transmitter and receiver installed within the same network can be managed using CCKM, ATEN's dedicated KVM over IP Matrix Manager.

---

7. Connect the unit to power, thereby turning it on, by plugging the power adapter provided into an AC power source and plugging its cable into the unit's DC power jack.
8. For more information on how to setup the KE6940AiT (example), please refer to its QSG or user manual.

---

**Note:** A keyboard or mouse with special functions may be required to be connected using the USB ports for the functions to work (see *USB Mode*, page 108).

---

# Installation Diagram

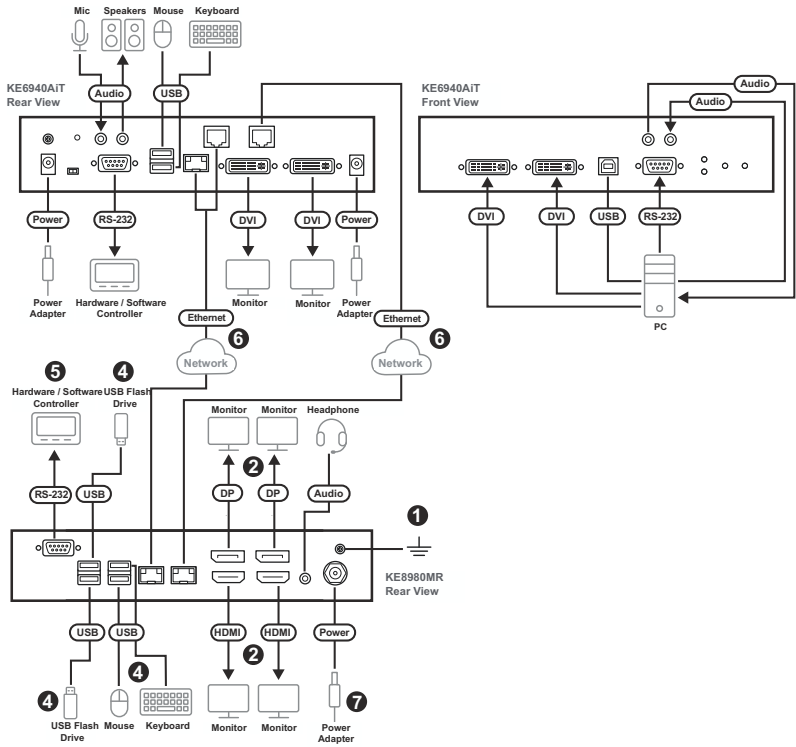

## **Things to Note**

Setting up the units on a network allows multipoint-to-multipoint computer to console operation by connecting multiple KE8980MR devices on the same TCP/IP LAN. Prior to the setup, we recommend laying out the plans for your KE installation using our performance guide (see *Keys to Network Performance*, page 58).

A few points to note during your setup:

- ◆ The units are preconfigured with factory-default network settings. If you install only one set of KE Series units, you do not need to change these default network settings. See *Default IP Addresses*, page 14, for further details.
- ◆ In a network setup with multiple units, each Transmitter and Receiver must be configured with a unique IP address. See *Network Configuration*, page 13, for further details.
- ◆ We recommend using 1000-Mbps Gigabit Ethernet switches (wire speeds, non-blocking with 1 Gbps / 1.5 Mpps performance per port) between KE Series devices installed on different LAN segments under a same office network environment. 10/100 Mbps switches might cause poor performance.
- ◆ In multipoint configurations, the IGMP and flow control function of your network switches/hubs must be enabled to avoid the deterioration of data throughput. To ensure functionality use a layer 3 switch that supports IGMP queries.
- ◆ If your network uses cascaded switches, please check to ensure the data throughput is sufficient.
- ◆ To get the best performance, we suggest creating a private network for KE devices, as they are bandwidth-intensive devices.
- ◆ Make sure that all equipment is powered off.

---

## Network Configuration

---

This section provides instructions to configure the network settings with a fixed IP address, subnet mask, and default gateway. To use the **IP Installer** to configure the IP address, see *IP Installer*, page 56.

- 
- Note:**
1. Both devices are preconfigured with factory-default network settings. If you install only one set of KE8980MR with the KE Series transmitter unit, you do not need to change these default network settings. See *Default IP Addresses*, page 14, for further details.
  2. In a network setup with multiple units, each transmitter and receiver must be configured with a unique IP address. See *Network Configuration*, page 13, for further details.
  3. We recommend using 1000-Mbps Gigabit Ethernet switches (wire speeds, non-blocking with 1 Gbps / 1.5 Mpps performance per port) between devices installed on different LAN segments under a same office network environment. 10/100 Mbps switches might cause poor performance.
  4. In multipoint configurations, the IGMP and flow control function of your network switches/hubs must be enabled to avoid the deterioration of data throughput. To ensure functionality use a layer 3 switch that supports IGMP queries.
  5. If your network uses cascaded switches, please check to ensure the data throughput is sufficient.
  6. To get the best performance, we suggest creating a private network for KE device, as they are bandwidth-intensive devices.
- 

To configure the network settings, do the following:

1. Set up the hardware and connect the transmitter and receiver to the local area network.
2. From the receiver, tap **[Scroll Lock]** twice to invoke the OSD.
3. Select the *Receiver* or *Transmitter* from the sidebar menu.
4. Enter the password and click **Configure**.  
The default password is: `password`.
5. From the *Network* tab, select **Set IP address manually** and enter the following:

- ◆ *IP Address* — sets the IP address for the KE device. Key in a valid unique IP address.

---

**Note:** See *Default IP Addresses*, page 14, for the preconfigured factory-default settings.

---

- ◆ *Subnet Mask* — sets the subnet mask for the KE device. Key in a valid subnet mask value.

---

**Note:** The default setting is 255.255.255.0

---

- ◆ *Default Gateway* — sets the default gateway for the KE device. Key in a valid default gateway.

6. Click **Save**.

## **Exit OSD**

To exit the OSD, press **[Esc]** on the keyboard, click **Logout**; tap **[Scroll Lock]** twice, or return to the OSD main page and press the front panel OSD pushbutton (receiver only).

At this point, the receiver can connect to the transmitter to access the remote computer (see *OSD Matrix Mode*, page 35 for instructions).

## **Default IP Addresses**

---

The preconfigured factory-default IP addresses for the KE Series devices are as follows:

Transmitters – 192.168.0.61

Receivers – 192.168.0.60

## KE I/O Ports

The following table provides the I/O port use of KE Series devices.

Device	Port	Number
KVM over IP Matrix Manager (TCP)	HTTP	8080
	HTTPS	8443
	Device TCP	9110
	Redundancy	9120
	Database Service	1527
KVM over IP Matrix Manager (UDP)	Port	9110
	Broadcast	9000
KE TX/RX Device (TCP)	Manager	9110
	Service	9000
	Telnet	23
	SSH	22
KE TX Device (TCP)	VM	9001
	vUSB	9002
	Serial	9003
	USB Access Mode	9009
KE TX/RX Device (UDP)	Manager	9110
	Service	9000
	Array Mode	9120
	Video	0xFE00(65024) - 0xFE03(65027)
	Audio	0xFE04(65028) - 0xFE05(65029)

## LED Display

---

Both the Transmitter and Receiver have front panel LEDs to indicate their operating and power status, as explained in the table below:

LED	Indication
LAN	<p>This LED indicates the network status.</p> <ul style="list-style-type: none"><li>◆ Lights when connected to the LAN and blinks when the Ethernet connection is active:<ul style="list-style-type: none"><li>◆ Orange: 10 Mbps</li><li>◆ Orange + Green: 100 Mbps</li><li>◆ Green: 1000 Mbps</li></ul></li><li>◆ Off when not connected to the LAN.</li></ul>
Power	<ul style="list-style-type: none"><li>◆ Lights blue when the unit is powered on.</li><li>◆ OFF when power is off.</li></ul>
Storage	<ul style="list-style-type: none"><li>◆ Lights orange when there is a flash drive connected to the unit and is operating.</li><li>◆ OFF there is no flash drive connected to the unit.</li></ul>

## CCKM KVM over IP Matrix Manager

---

The *CCKM KVM over IP Matrix Manager* is a browser based GUI that provides management of KE Series devices over a network. You can download the KVM over IP Matrix Manager for free and manage up to 8 KE devices, or purchase a license for the KVM over IP Matrix Manager.

- ◆ To purchase a license, contact your local authorized ATEN dealer.
- ◆ To download and install the free KVM over IP Matrix Manager, and how to access and operate the software, please refer to the *ke-series-cckm-user-manual*.

# Chapter 3

## OSD Operation

### Overview

---

This chapter provides instructions to configure and operate KE8980MR using the local On Screen Display (OSD). To configure the network settings with the OSD, see *Network Configuration*, page 13.

### Invoking the OSD

---

The On Screen Display (OSD) is a keyboard/mouse-driven application on the receiver used to configure the transmitter and receiver settings. Once the receiver has discovered the transmitter over a network\* or Ethernet cable connection, you can use the OSD on the receiver to configure the transmitter.

To invoke the OSD, from the keyboard tap the **Scroll Lock** key twice. The *OSD* main page will appear (see *OSD Interface*, page 18).

To exit the OSD, press **[Esc]** on the keyboard; click **Logout**; tap the **Scroll Lock** key twice. The OSD disappears and the computer desktop screen or the System Login prompt is displayed.

- 
- Note:** 1. For the Receiver to discover the Transmitter over a network, both must be on the same subnet of the LAN.
2. If the keyboard/mouse won't work when the OSD is invoked, see *USB Mode*, page 108.
- 

### Touch Screen Calibration

If you're using a touch screen monitor and the OSD appears off center, you can use the blinking **+** at each corner to adjust the position of the OSD.

## OSD Interface

---

After you invoke the OSD, the main page appears:

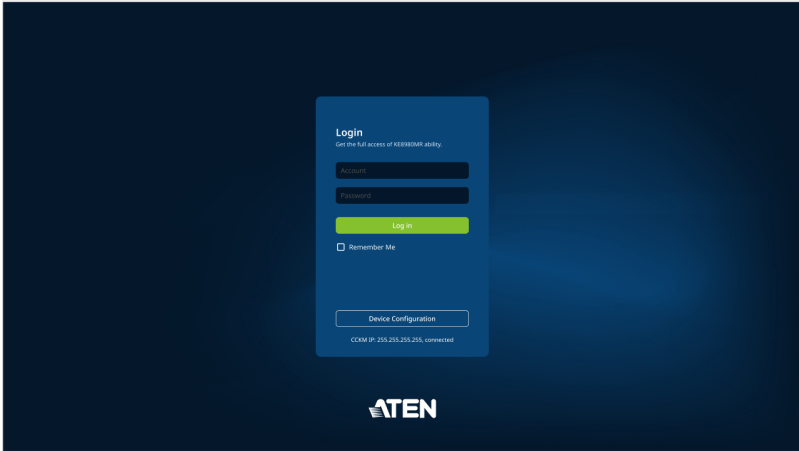

Click to Device Configuration to make system changes to the KE8980MR.

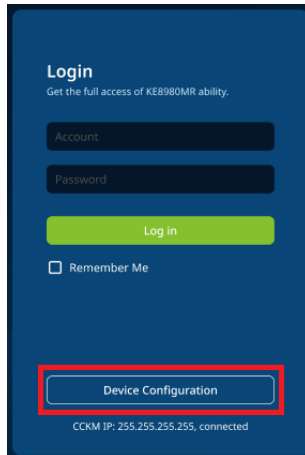

From the Device Configuration login page, enter the correct password.

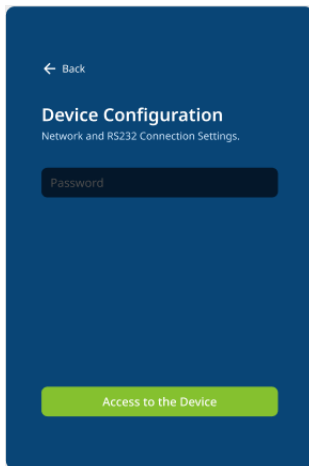

**Note:** A password is required to enter the OSD. The default password is: *password*. For security purposes, the system will prompt you to change the password.

Once you have successfully entered to the Device Configuration page, the following page appears.

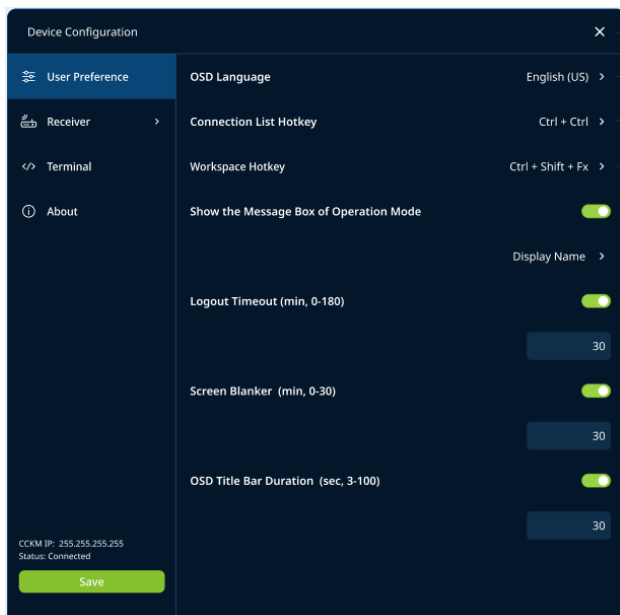

## User Preference Tab

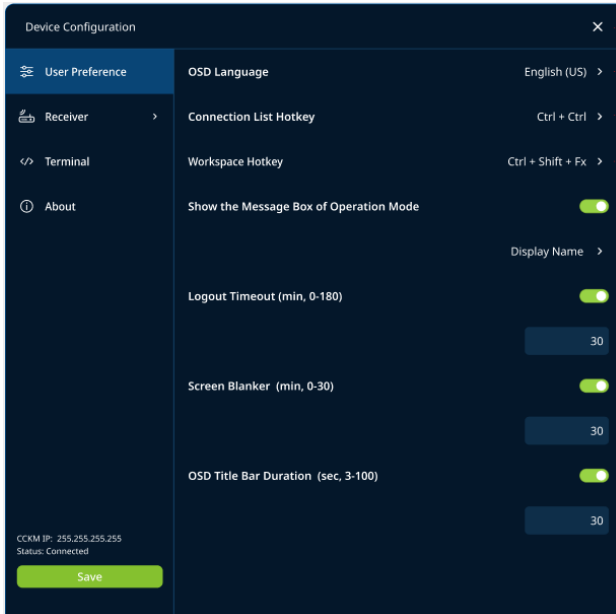

The components are described in the table below:

Item	Description
OSD Language	Click the drop-down menu to select the language you want to use for OSD sessions. Choices are: English, Chinese (Simplified), Chinese (Traditional), Japanese, Korean, Dutch, French, Spanish, Portuguese, and Russian.
Connection List Hotkey	Click the drop-down menu to select a connection list hotkey you want to use for OSD sessions.
Workspace Hotkey	Click the drop-down menu to select a workspace hotkey you want to use for OSD sessions.
Show the Message Box of Operation Mode	Enable / disable the message box of operation mode.
Logout Timeout (min, 0-180)	Enable / disable the logout timeout. When enabled, specify when to automatically log out a user if there is no user input for the amount of time set.
Screen Blanker (min, 0-30)	Enable / disable the screen blanker. When enabled, specify a time frame that the OSD waits when a session is idle before turning off the display.
OSD Title Bar Duration (sec, 3-100)	Enable / disable the OSD title bar duration. When enabled, specify a duration for the OSD title bar.

When you have made your choices, Click **Save**.

## Receiver Tab

Click on the Receiver drop-down menu and the receiver tab appears:

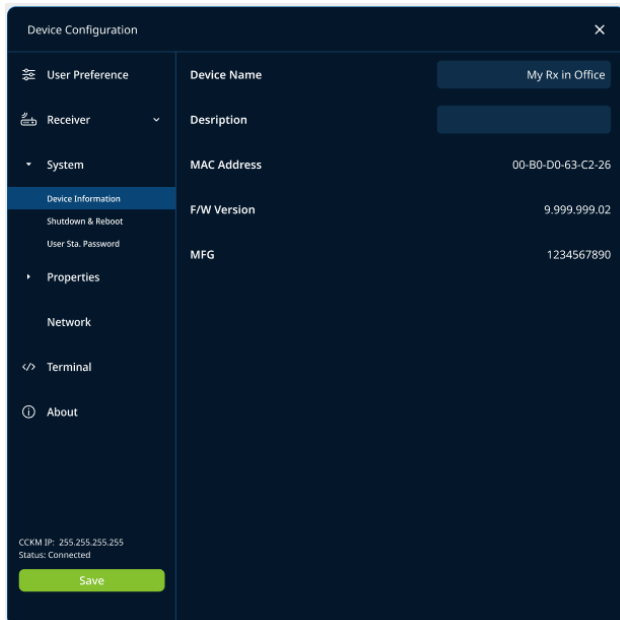

## System Settings

In the System Settings, Device Information, Shutdown & Reboot, and User Sta. Password are available for configurations or actions.

Device Information: See *Device Information*, page 22.

Shutdown & Reboot: See *Shutdown & Reboot*, page 23.

User Sta. Password: See *User Sta. Password*, page 24.

## Device Information

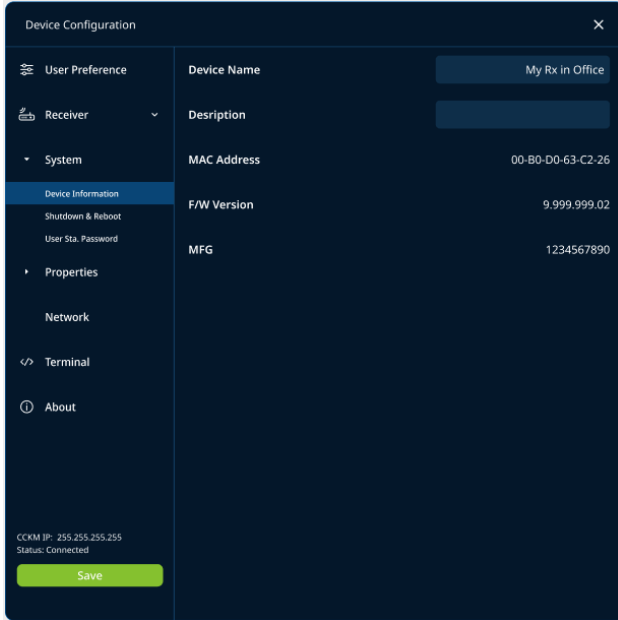

The components are described in the table below:

Item	Description
Device Name	Sets a device name for this device.
Description	Sets a device description for this device.
MAC Address	Shows the MAC address for this device.
F/W Version	Shows the firmware version for this device.
MFG	Shows the MFG information for this device.

When you have made your choices, Click **Save**.

## Shutdown & Reboot

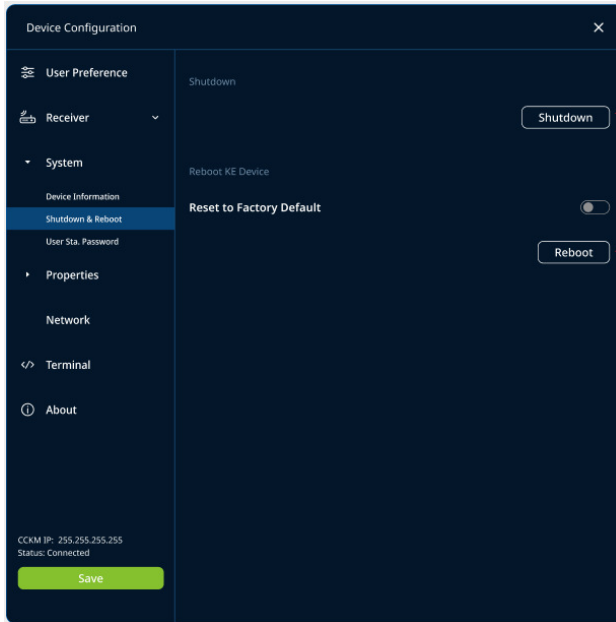

The components are described in the table below:

Item	Description
Shutdown	Click shutdown to shutdown the device.
Reboot KE Device	<ul style="list-style-type: none"> <li>◆ To reset the device, enable Reset to Factory Default and click Reboot.</li> <li>◆ To reboot the device, simply click Reboot.</li> </ul>

## User Sta. Password

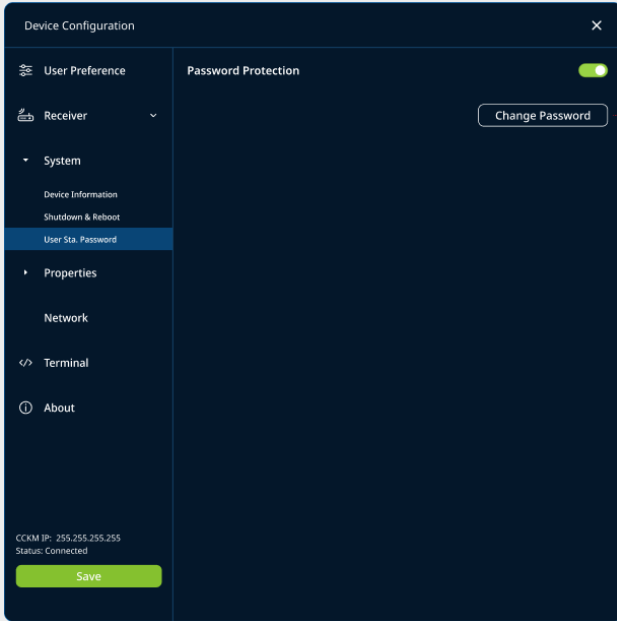

The components are described in the table below:

Item	Description
Password Protection	<ul style="list-style-type: none"> <li>◆ To enhance password protection, enable Password Protection and click Change Password.</li> <li>◆ To change password, simply click Change Password.</li> </ul>

When you have made your choices, Click **Save**.

## **Properties Settings**

In the Properties Settings, General, RS-232 Settings, Properties, Manage Address, USB Mode, and Network are available for configurations.

General: See *General*, page 26.

RS-232 Settings: See *RS-232 Settings*, page 27.

Properties: See *Properties*, page 28.

Manage Address: See *Manage Address*, page 29.

USB Mode: See *USB Mode*, page 30.

Network: See *Network*, page 32.

## General

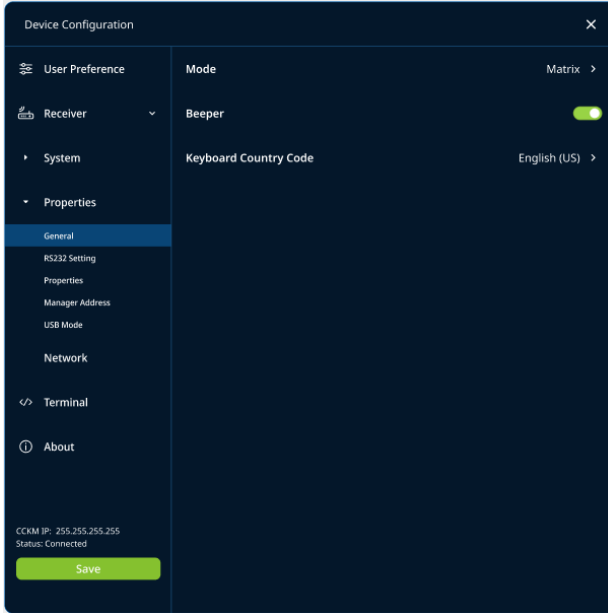

The components are described in the table below:

Item	Description
Mode	Select <b>Matrix</b> mode to manage devices and connections from the KVM over IP Matrix Manager web GUI. This mode is for advanced administration of Transmitter to Receiver connections (see <i>Browser / Telnet Operation</i> , page 63).
Beeper	Enable / disable the beeper, this allow the Receiver to beep when configuration changes are made to it.
Keyboard Country Code	Use the drop-down menu to select the Receiver's language keyboard for use in the OSD.

When you have made your choices, Click **Save**.

## RS-232 Settings

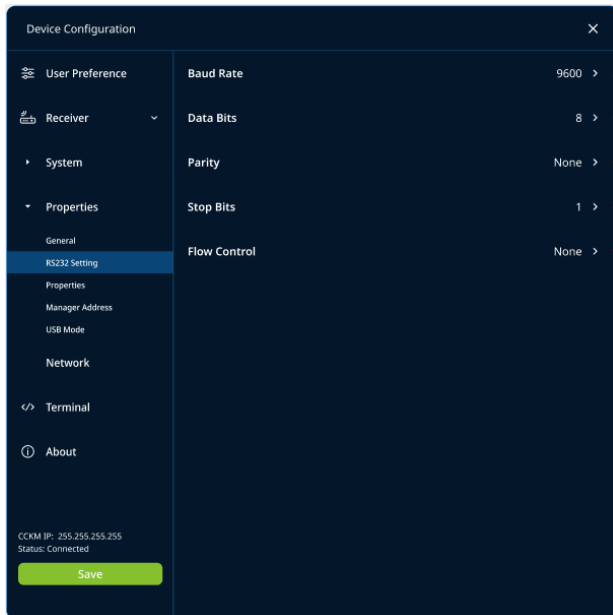

The components are described in the table below:

Item	Description
Baud Rate	Configure the serial device settings for the Receiver. The default settings are: Baud Rate: 9600 Parity: None Data Bits: 8 bits Stop bits: 1 bit Flow Control: None
Data Bits	
Parity	
Stop Bits	
Flow Control	

When you have made your choices, Click **Save**.

## Properties

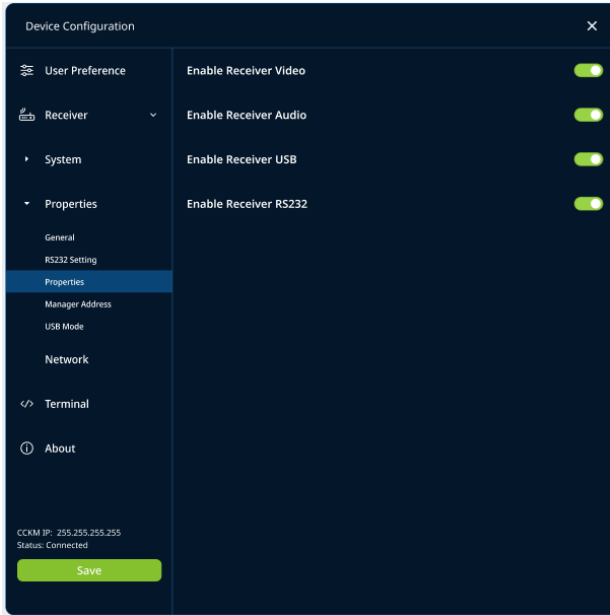

The components are described in the table below:

Item	Description
Enable Receiver Video	Enable / disable the receiver video source signal.
Enable Receiver Audio	Enable / disable the receiver audio source signal.
Enable Receiver USB	Enable / disable the receiver USB source signal.
Enable Receiver RS-232	Enable / disable the receiver RS-232 source signal.

When you have made your choices, Click **Save**.

## Manage Address

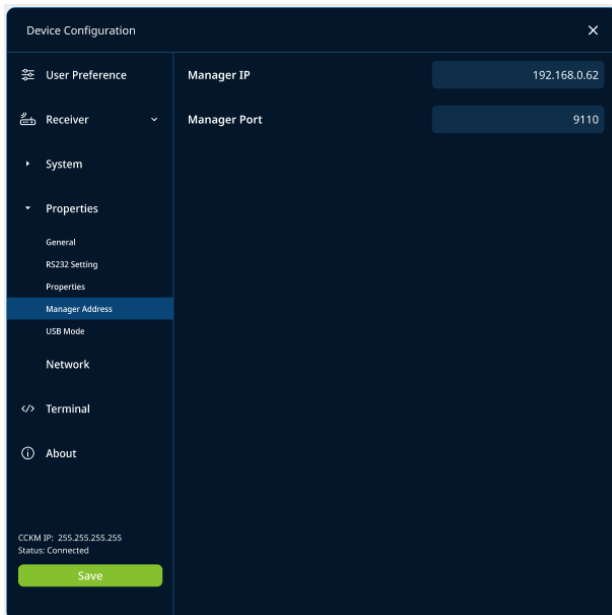

The components are described in the table below:

Item	Description
Manager IP	Set the IP address and port number of the computer running the KVM over IP Matrix Manager. The default port number is 9110.
Manager Port	

When you have made your choices, Click **Save**.

## USB Mode

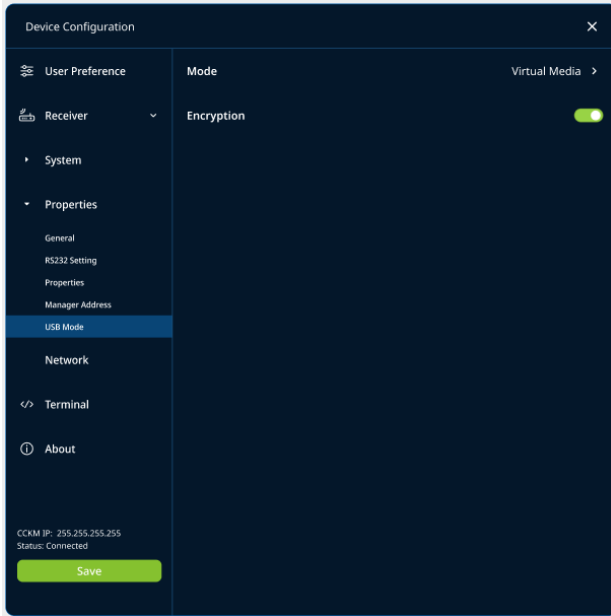

The components are described in the table below:

Item	Description
Mode	Select the type of USB device you will connect to the USB ports:
Encryption	<p><b>Virtual Media:</b> Only select this option if you are plugging a USB flash drive into the USB ports. This will give you the highest data transfer speeds but cannot work with other USB devices. When Receivers mount or unmount USB flash drives, the keyboard and mouse operations will experience a brief delay. Each Transmitter and Receiver can respectively support up to 12 and 3 virtual media connections at the same time (including Tx local console USB keyboard and mouse).</p> <p><b>vUSB (generic USB device):</b> Use this option to plug USB peripherals into the USB ports.</p> <p><b>Note:</b> The USB option also allows a keyboard and mouse with special functions to be plugged into the USB ports for console use. Use this only if the special functions of the keyboard or mouse are required but do not work when plugged into the console ports. When the keyboard and mouse are plugged into the USB ports, they will not work within the OSD menus. To work within the OSD menus, the keyboard and mouse must be plugged into the console ports.</p> <p><b>Encryption:</b> Enable / disable the encryption to encrypt USB drives plugged into the USB ports.</p>

When you have made your choices, Click **Save**.

## Network

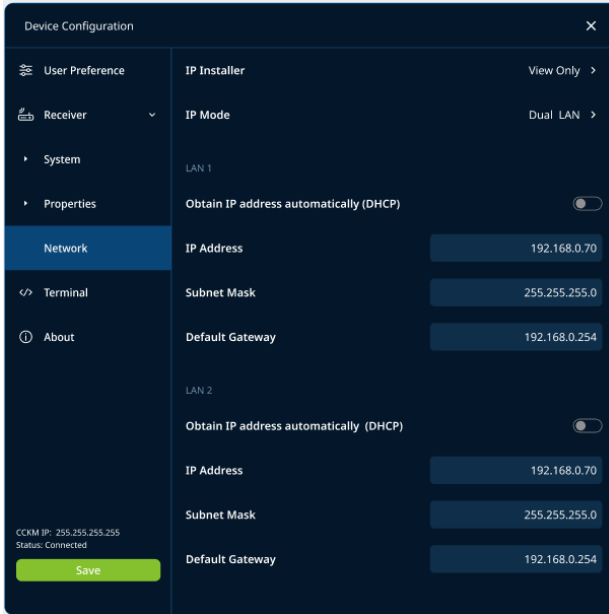

The components are described in the table below:

Item	Description
IP Installer	The IP Installer is an external Windows-based utility for assigning an IP address to the device. Click to select <b>Enable</b> , <b>View Only</b> , or <b>Disable</b> for the IP Installer utility. See <i>IP Installer</i> , page 56 for instructions. <b>Note:</b> For security, we strongly recommend that you set this to <i>View Only</i> or <i>Disable</i> after each use.
IP Mode	Click to select <b>Dual LAN</b> or <b>Redundancy</b> for the IP mode.
LAN 1 / LAN 2	
Obtain IP Address Automatically (DHCP)	For dynamic IP address assignment (DHCP), enable the <b>Obtain IP address automatically (DHCP)</b> .
IP Address	To specify a fixed <i>IP Address</i> , <i>Subnet Mask</i> , and <i>Default Gateway</i> disable the <b>Obtain IP address automatically (DHCP)</b> and fill in the fields with values appropriate for your network.
Subnet Mask	
Default Gateway	<b>Note:</b> For help configuring network settings with the OSD, see <i>Network Configuration</i> , page 13.

When you have made your choices, Click **Save**.

## Terminal Tab

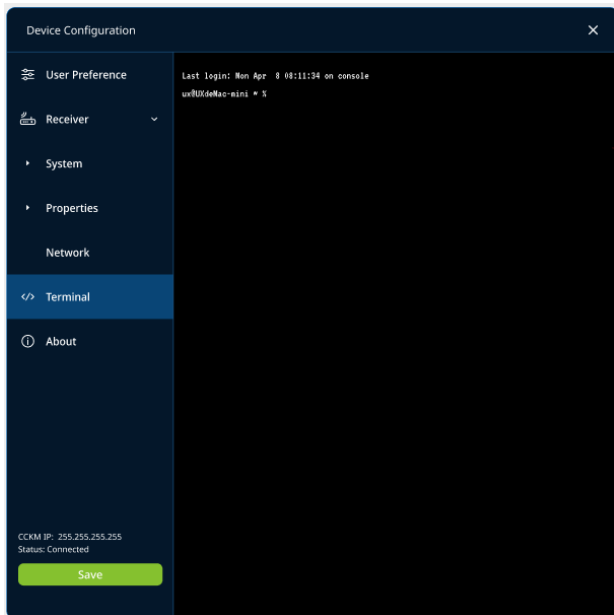

The KE980MR can be operated and configured via a terminal session.

## About Tab

---

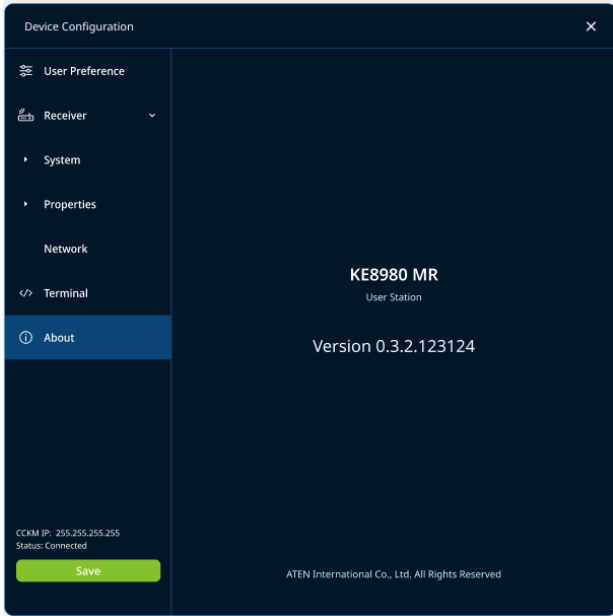

Shows the device and firmware version of the KE8980MR.

## OSD Matrix Mode

If you set the system to Matrix mode (in Properties > General), you will see the *System Login* screen when you enter the invoke the OSD, which provides access to the *Connection Page* by entering a username and password:

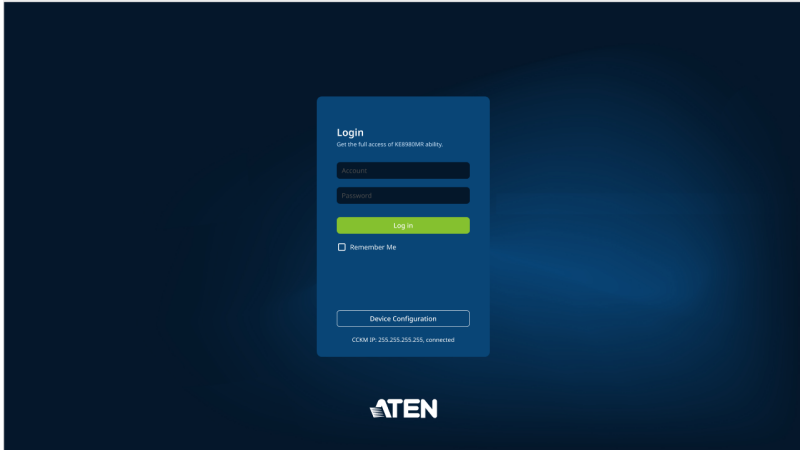











After you login the *Connection Page* appears, as shown on the next page.





### Toolbar

#### Multi-view Mode Toolbar



The functions are described in the table below.

Icon	Function
	This is a toggle. Click to make the Control Panel persistent – i.e., it always displays on top of other screen elements. Click again to have it display normally.
	Show / hide the connection list. See <i>Multi-view Mode List</i> , page 39.
	Create a new window.
	This is a toggle. Click to lock / unlock the current window.
	Choose a different layout or use the drop-down menu to show a list of layouts.
	
	
	
	
	





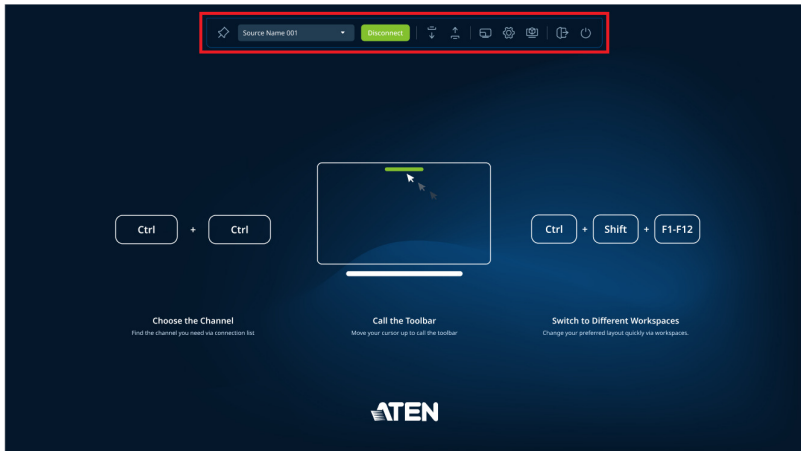

	Click to go to operation mode.
	Click to go to device configuration page.
	Reserved for future expansion.
	Click to logout.
	Click to shutdown or reboot the device.

## Operation Mode Toolbar



The functions are described in the table below.

Icon	Function
	This is a toggle. Click to make the Control Panel persistent – i.e., it always displays on top of other screen elements. Click again to have it display normally.



<div style="background-color: #2c3e50; color: white; padding: 2px; border: 1px solid #2c3e50;">Source Name 001 ▾</div>	<p>Show the connection list. See <i>Operation Mode List</i>, page 40.</p>
	<p>Pull content. See <i>Pull Content</i>, page 43.</p>
	<p>Push content. See <i>Push Content</i>, page 42.</p>
	<p>Click to go to multi-view mode.</p>
	<p>Click to go to device configuration page.</p>
	<p>Reserved for future expansion.</p>
	<p>Click to logout.</p>
	<p>Click to shutdown or reboot the device.</p>

## Connection List

### Multi-view Mode List



The *Connection Page* components are described in the table below:

Item	Description
Search	Search for transmitters based on the keyword(s) entered.
	Click to show only the favorite connection list.
	Click to show the connection list in a list view.
	Click to show the connection list in a panel view. This is only available when the list-view is selected.

## Operation Mode List





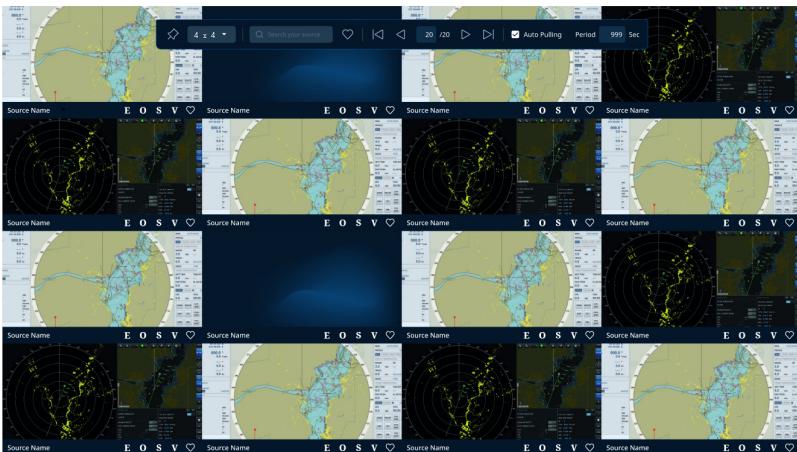

Use the drop-down menu to select a different source device.

## Array Mode

In *Array Mode* the screen is divided into a grid of panels, with each panel showing the video display of a particular Channel. Right-click a panel and select a mode to connect: **E**: Exclusive, **O**: Occupy, **S**: Share, **V**: View Only, **X**: Exit. While the mouse cursor hovers over a panel displaying video, if audio is being sent from that Transmitter, it can be heard at the Receiver.

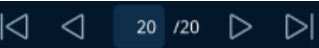

Item	Description
	<p>This is a toggle. Click to make the Control Panel persistent – i.e., it always displays on top of other screen elements. Click again to have it display normally.</p>
	<p>Select a range for how many Channels you want to display. Options are: 4x4, 5x5, and 6x6.</p>
	<p>Click <b>Favorites</b> to list only the Channels marked as favorites. Click <b>All</b> to list all Channels.</p> <p>To add/remove a Favorite, go to List Mode, select a Channel and then right click with the mouse to select <b>Add to Favorite</b> or <b>Remove from Favorite</b>.</p> <p><b>Note:</b> A maximum of 50 channels can be marked as <i>Favorites</i>.</p>
	<ul style="list-style-type: none"> <li>◆ Use these two buttons to navigate to the next page or to the end of the list if there are more Channels available than can be seen on the page.</li> <li>◆ Use these two buttons to navigate to the previous page or to the beginning of the list if there are more Channels available than can be seen on the page.</li> </ul>
	<p>Enable and set a period in seconds for auto pulling.</p>

## Push Content

*Push Content* allows you to push the Receiver's computer connection to another Receiver's console, allowing both to access to the computer. Click the *Push* icon from the Toolbar and the following screen appears:



The *Push Content Page* components are described in the table, below:

No.	Item	Description
1	Receiver Name	Lists the Receivers that can be selected to push the local Receiver's computer connection to.
2	Description	The field provides a description of the Receiver that was entered when it was created.
3	Connect	Click <b>Push Content</b> to push the local Receiver's computer connection to the selected Receiver's console. The local Receiver's computer connection will appear on the Receiver that it was pushed to and both will share access to the computer. The access mode selected at the local Receiver will determine how access is shared.

## Pull Content

*Pull Content* allows you to pull a Receiver's computer connection to the local Receiver's console, allowing both to access to the computer. Click the *Pull* icon from the Toolbar and the following screen appears:

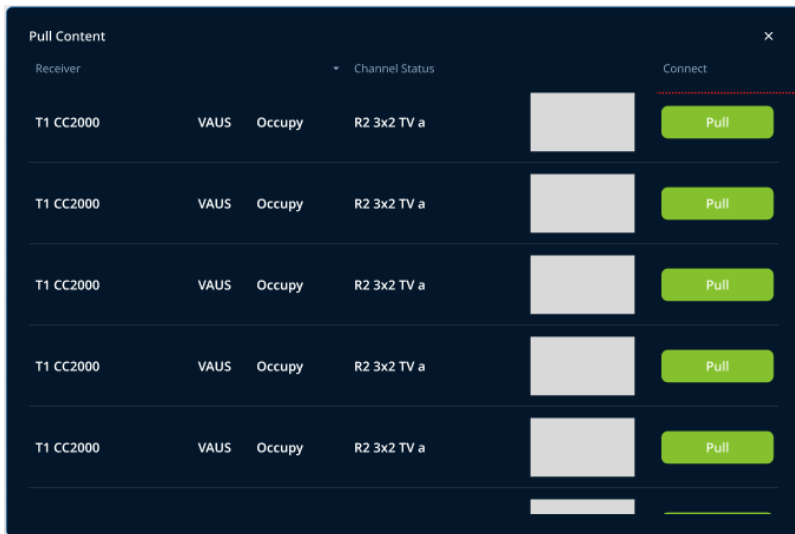

The *Pull Content Page* components are described in the table, below:

No.	Item	Description
1	Receiver Name	Lists the Receiver names currently connected to the Channel listed under <i>Channel Status</i> .
2	Channel Status	Lists the name, description and access type of each available Channel connection.
3	Connect	Click <b>Pull Content</b> and the Receiver will pull the Channel connection to the local console using the access mode displayed under Channel Status.

This Page Intentionally Left Blank

## Chapter 4

# Firmware Upgrade Utility

The Windows-based Firmware Upgrade Utility (FWUpgrade.exe) provides a smooth, automated process for upgrading the firmware. The Utility comes as part of a Firmware Upgrade Package that is specific for each device. New firmware upgrade packages are posted on our web site as new firmware revisions become available. Check the web site regularly to find the latest packages and information relating to them:

<http://www.aten.com>

For browser based firmware upgrade, please refer to *FW Upgrade* on page 154.

### Preparation

---

1. From a computer that is not part of your installation go to our Internet support site and choose the model name that relates to your KE device to get a list of available Firmware Upgrade Packages.
2. Choose the Firmware Upgrade Package you want to install (usually the most recent), and download it to your computer.
3. Be sure that the computer is connected to the same LAN segment as the KE devices.

## Starting the Upgrade

To upgrade your firmware:

1. Run the downloaded Firmware Upgrade Package file - either by double clicking the file icon, or by opening a command line and entering the full path to it. The Firmware Upgrade Utility Welcome screen appears:

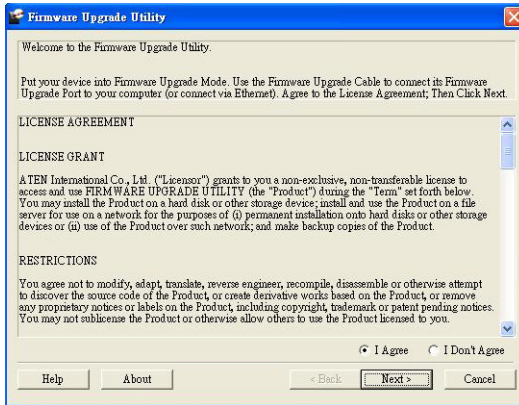

**Note:** The screens shown in this section are for reference only.

2. Read the License Agreement (enable the *I Agree* radio button).
3. Click **Next**. The Firmware Upgrade Utility main screen appears:

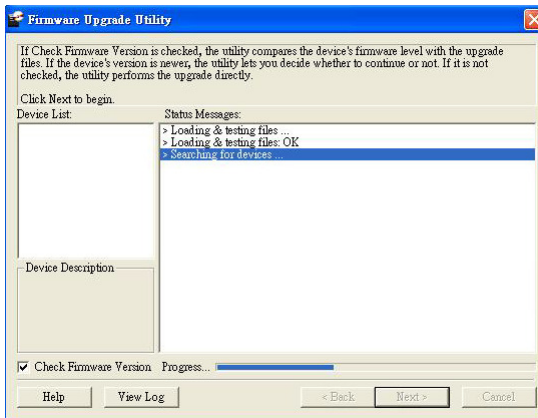

- The Utility inspects your installation. All the devices capable of being upgraded by the package are listed in the *Select Master Device* list.

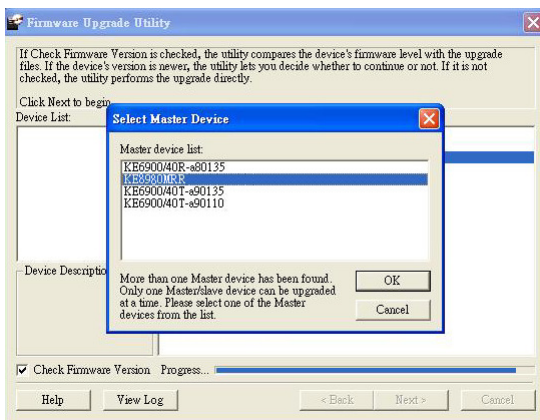

- After you have made your device selection, Click **OK** and then **Next** to begin the upgrade.

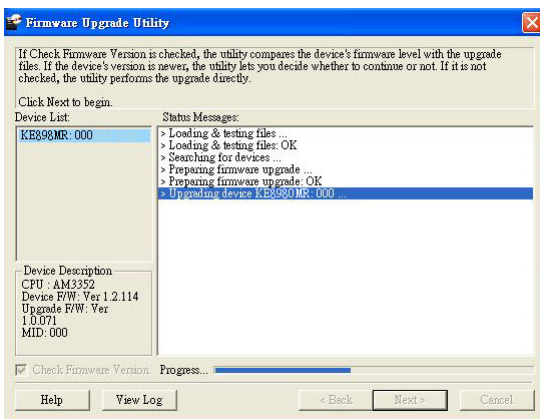

If you enabled *Check Firmware Version*, the Utility compares the device's firmware level with that of the upgrade files. If it finds that the device's version is higher than the upgrade version, it brings up a dialog box informing you of the situation and gives you the option to **Continue** or **Cancel**.

If you didn't enable *Check Firmware Version*, the Utility installs the upgrade files without checking whether they are a higher level, or not.

As the Upgrade proceeds status messages appear in the Status Messages panel, and the progress toward completion is shown on the *Progress* bar.

## Upgrade Succeeded

After the upgrade has completed, a screen appears to inform you that the procedure was successful:

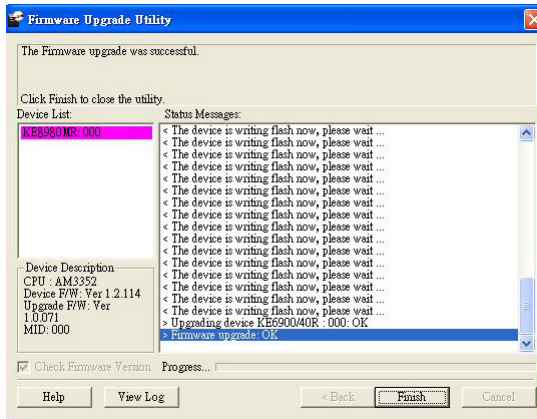

## Firmware Upgrade Recovery

---

If the Upgrade Succeeded screen doesn't appear or the upgrade procedure is abnormally halted (due to computer crash, power failure, etc.), the device may become inoperable. If you find that the device does not work following a failed or interrupted upgrade, do the following

1. Power off the KE device.
2. Press the **Reset** button, then power on the KE device while holding Reset.
3. Hold **Reset** for 7 seconds after the device is powered on.
4. The device will revert to a previous firmware version and recover from the failure.
5. Upgrade the firmware to the most current version available.

This Page Intentionally Left Blank

## Safety Instructions

---

### General

- ◆ This product is for indoor use only.
- ◆ Read all of these instructions. Save them for future reference.
- ◆ Follow all warnings and instructions marked on the device.
- ◆ Do not place the device on any unstable surface (cart, stand, table, etc.). If the device falls, serious damage will result.
- ◆ Do not use the device near water.
- ◆ Do not place the device near, or over, radiators or heat registers.
- ◆ The device cabinet is provided with slots and openings to allow for adequate ventilation. To ensure reliable operation, and to protect against overheating, these openings must never be blocked or covered.
- ◆ The device should never be placed on a soft surface (bed, sofa, rug, etc.) as this will block its ventilation openings. Likewise, the device should not be placed in a built in enclosure unless adequate ventilation has been provided.
- ◆ Never spill liquid of any kind on the device.
- ◆ Avoid circuit overloads. Before connecting equipment to a circuit, know the power supply's limit and never exceed it. Always review the electrical specifications of a circuit to ensure that you are not creating a dangerous condition or that one doesn't already exist. Circuit overloads can cause a fire and destroy equipment.
- ◆ Unplug the device from the wall outlet before cleaning. Do not use liquid or aerosol cleaners. Use a damp cloth for cleaning.
- ◆ The device should be operated from the type of power source indicated on the marking label. If you are not sure of the type of power available, consult your dealer or local power company.
- ◆ To prevent damage to your installation it is important that all devices are properly grounded.
- ◆ Do not allow anything to rest on the power cord or cables. Route the power cord and cables so that they cannot be stepped on or tripped over.
- ◆ Position system cables and power cables carefully; Be sure that nothing rests on any cables.

- ◆ Never push objects of any kind into or through cabinet slots. They may touch dangerous voltage points or short out parts resulting in a risk of fire or electrical shock.
- ◆ Do not attempt to service the device yourself. Refer all servicing to qualified service personnel.
- ◆ If the following conditions occur, unplug the device from the wall outlet and bring it to qualified service personnel for repair.
  - ◆ The power cord or plug has become damaged or frayed.
  - ◆ Liquid has been spilled into the device.
  - ◆ The device has been exposed to rain or water.
  - ◆ The device has been dropped, or the cabinet has been damaged.
  - ◆ The device exhibits a distinct change in performance, indicating a need for service.
  - ◆ The device does not operate normally when the operating instructions are followed.
- ◆ Only adjust those controls that are covered in the operating instructions. Improper adjustment of other controls may result in damage that will require extensive work by a qualified technician to repair.

## **Rack Mount**

- ◆ Before working on the rack, make sure that the stabilizers are secured to the rack, extended to the floor, and that the full weight of the rack rests on the floor. Install front and side stabilizers on a single rack or front stabilizers for joined multiple racks before working on the rack.
- ◆ Always load the rack from the bottom up, and load the heaviest item in the rack first.
- ◆ Make sure that the rack is level and stable before extending a device from the rack.
- ◆ Use caution when pressing the device rail release latches and sliding a device into or out of a rack; the slide rails can pinch your fingers.
- ◆ After a device is inserted into the rack, carefully extend the rail into a locking position, and then slide the device into the rack.
- ◆ Do not overload the AC supply branch circuit that provides power to the rack. The total rack load should not exceed 80 percent of the branch circuit rating.
- ◆ Make sure that all equipment used on the rack – including power strips and other electrical connectors – is properly grounded.
- ◆ Ensure that proper airflow is provided to devices in the rack.
- ◆ Ensure that the operating ambient temperature of the rack environment does not exceed the maximum ambient temperature specified for the equipment by the manufacturer.
- ◆ Do not step on or stand on any device when servicing other devices in a rack.

## Technical Support

---

### International

- ◆ For online technical support – including troubleshooting, documentation, and software updates: **<http://support.aten.com>**
- ◆ For telephone support, see *Telephone Support*, page iv.

### North America

Email Support		<a href="mailto:support@aten-usa.com">support@aten-usa.com</a>
Online Technical Support	Troubleshooting Documentation Software Updates	<a href="http://www.aten-usa.com/support">http://www.aten-usa.com/support</a>
Telephone Support		1-888-999-ATEN ext 4988 1-949-428-1111

When you contact us, please have the following information ready beforehand:

- ◆ Product model number, serial number, and date of purchase.
- ◆ Your computer configuration, including operating system, revision level, expansion cards, and software.
- ◆ Any error messages displayed at the time the error occurred.
- ◆ The sequence of operations that led up to the error.
- ◆ Any other information you feel may be of help.

# Specifications

## KE8980MR

Function		KE8980MR
Connectors	USB Port	2 x USB Type A Female (Blue)
	Console Port	2 x USB Type A Female (Blue)
	Power	2 x DisplayPort Female (Black) 2 x HDMI Female (Black)
	LAN Ports	1 x Audio Line Out / In Jack (Black) 1 x DB-9 Male (Black) 1 x Lockable DC Jack (Black) 2 x RJ-45 (Blue)
Pushbuttons		1 x Power (Black) 1 x Reset (Black)
LEDs	Power	1 (Blue)
	Storage	1 (Orange)
Emulation	Keyboard / Mouse	USB
Power Consumption		DC19V:33W:420BTU/h
		<p><b>Note:</b></p> <ul style="list-style-type: none"> <li>◆ The measurement in Watts indicates the typical power consumption of the device with no external loading.</li> <li>◆ The measurement in BTU/h indicates the power consumption of the device when it is fully loaded.</li> </ul>
Video Resolution		Up to 4 * 4096 x 2160 @ 60 Hz
Latency		Operation Mode: 5ms ~ 48ms Multiview Mode: < 48ms
Environment	Operating Temp.	-10 – 50 °C
	Storage Temp.	-40 – 85°C
	Humidity	10–90% RH, Non-condensing
Physical Properties	Housing	Metal
	Weight	1.34 kg (2.95 lb)
	Dimensions (L x W x H)	20.00 x 19.00 x 4.18 cm (7.87 x 7.48 x 1.65 in)

## IP Installer

From a client computer running Windows, an IP address for a transmitter or receiver can be assigned with the IP Installer utility. The utility can be obtained from the Download area of our website or from the product page on the *Software & Driver* tab. After downloading the utility to your client computer, do the following:

1. Unzip the contents of IPInstaller.zip to a directory on your hard drive.
2. Go to the directory that you unzipped the IPInstaller program to and run IPInstaller.exe. A dialog box similar to the one below appears:

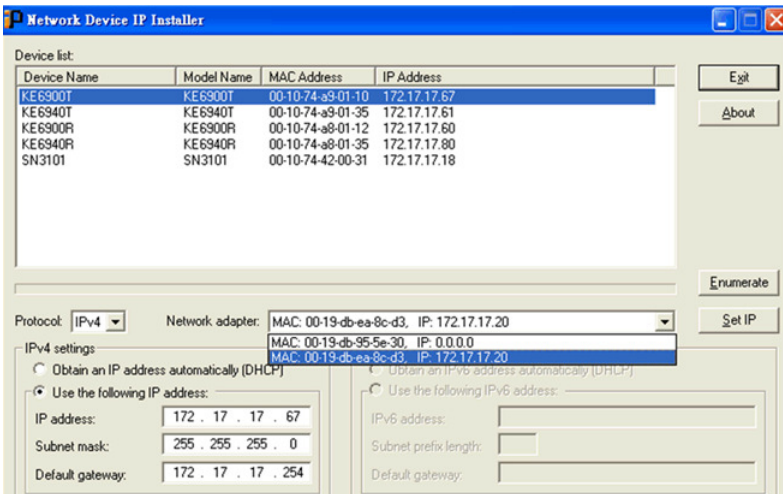

3. Select the Transmitter or Receiver in the Device List.

**Note:** 1. If the list is empty, or your device doesn't appear, click **Enumerate** to refresh the Device List.

2. If there is more than one device in the list, use the MAC address to pick the one you want. The MAC address is located on the devices bottom panel.

4. Select either *Obtain an IP address automatically (DHCP)*, or *Specify an IP address*. If you chose the latter, fill the IP Address, Subnet Mask, and Gateway fields with the information appropriate to your network.
5. Click **Set IP**.
6. After the IP address shows up in the Device List, click **Exit**.

## RS-232 Pin Assignments

Pin assignments for the Transmitter and Receiver's rear RS-232 port that is used for connecting to a serial terminal are given in the table, below:

Pin	Assignment	
1	N/A	None
2	RXD	Receive Data
3	TXD	Transmit Data
4	DTR	Data Terminal Ready
5	GND	Signal Ground
6	DSR	Data Set Ready
7	RTS	Request to Sent
8	CTS	Clear to Sent
9	N/A	None

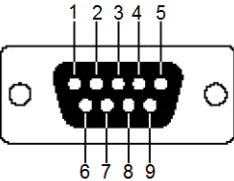

**DB9 Male**

### Transmitter Front RS-232 Port

Pin assignments for the Transmitter's front RS-232 port that is used for connecting to a computer for serial control are given in the table, below:

Pin	Assignment	
1	N/A	None
2	TXD	Transmit Data
3	RXD	Receive Data
4	DSR	Data Set Ready
5	GND	Signal Ground
6	DTR	Data Terminal Ready
7	CTS	Clear to Sent
8	RTS	Request to Sent
9	N/A	None

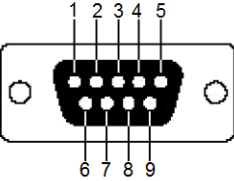

**DB9 Female**

## **Keys to Network Performance**

---

For optimum performance, KE Series devices requires high amounts of data to be transferred across a network; therefore we recommend the following strategies to setup KE Series devices. Using our suggestions will provide better performance and the highest video resolutions possible. Use each of the keys to ensure the best transmission of data and the highest throughput possible.

### **Build a Network Diagram**

To build an effective KE installation, start by mapping out the layout. Create a diagram with the KE devices, computers and routers along with how they will be connected across the network. It also helps to write out how the devices will interact. Use this diagram as the frame work as you decide what devices to purchase and how to build the network effectively for the best data throughput.

Considerations:

- ◆ If possible, create a private network for the KE devices
- ◆ Use the same switch model throughout
- ◆ Use a flat cascaded layout
- ◆ Avoid a tree or pyramid structure
- ◆ Limit cascades to two levels
- ◆ Install network switches near each other
- ◆ Minimize the distance of connections
- ◆ Install KVM over IP Matrix Manager (CCKM) computer and KE devices on the same subnet
- ◆ Check the 3 Other Factors before installation

### **Other Factors**

#### **■ Choose the Right Cable**

Always use Cat 5/6e Ethernet cable or higher installed by a professional between any two devices you are installing. We recommend using ATEN Brand Ethernet cable to ensure the quality. It's best when installing KE devices to use brand new Ethernet cabling for each part of the installation to ensure the reliability of the data being transmitted. This is a key to getting the best uninterrupted video resolution across the network.

## ■ Determine the Distance

Distance is an important factor when setting up networks, with a shorter distance and fewer hops through routers, data can be transmitted more efficiently. So whenever possible decrease the distance and direct network traffic effectively between subnets that communicate with each other to increase the data throughput.

## ■ Ensure the Bandwidth

Ensuring the bandwidth ahead of time will guarantee performance before installing KE devices on a network. This will eliminate the primary cause of problems related to video quality and transmission of data. If the speed is right at all ends of your network, then the only other causes are derived from device failure or limits caused by a router, switch or device setting.

## Sample Network Diagram

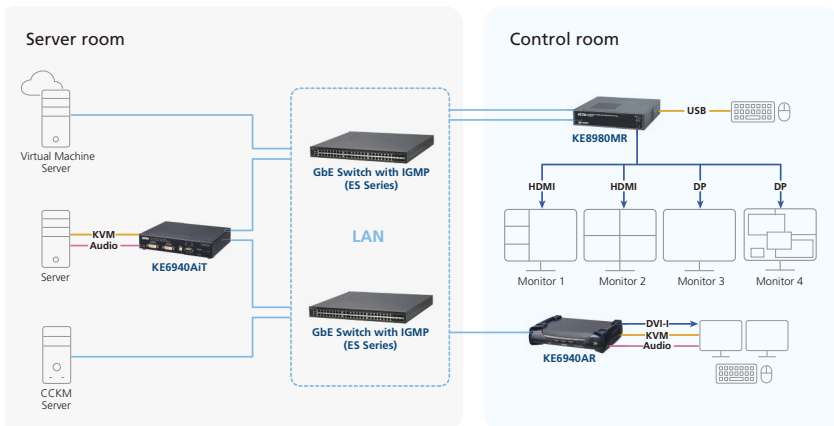

## **Choose a High Performance Switch**

A high performance network switch is the means of a successful KE setup. When choosing a network switch, first select the type:

### **Layer 2 or Layer 3 Switches**

You'll need to determine whether you need a layer 2 or a layer 3 switch for your KE network. Layer 3 switches cost more than layer 2 switches because they are more complex and handle more network traffic. The best way to calculate which type of switch you need is to first determine if you will have a dedicated network for the KE devices or if the KE devices will be on a network that shares throughput with other network equipment such as computers, servers and printers. If they share the network with other devices its best to consider a layer 3 switch and use layer 2 switches exclusively for the KE device connections. For larger installations we recommend using Layer 3 switches. The major differences are:

**Layer 3 Switch:** IP addresses in packets are examined and intelligent forwarding decisions are made. On a larger network broken into subnets across long distances, a layer 3 switch becomes the best choice as they can improve network efficiency and provide better traffic flow. They are better at directing more traffic to different locations on a larger more complex network, and with layer two switches working below them.

**Layer 2 Switch:** Packets are examined and forwarded using only the MAC address. If you have a small central network, a layer 2 switch should do the job. If the network is exclusive and will only transmit the bandwidth of KE devices, layer 2 switches with the correct settings can get the job done effectively.

## **Considerations**

### **Number of ports**

Choose a switch that has enough ports to match the number of KE devices you will be installing. Switches typically come in 5, 8, 10, 16, 24, 28, 48, and 52-port configurations. If you are installing 13 KE transmitters and 13 KE receivers, you will need to purchase a switch with at least 28 ports.

### **Stackable verse Standalone**

Stackable switches allow you to easily manage and configure ports spanning across multiple switches that the KE devices are connected through. This provides a centralized method to configure and troubleshoot the initial setup of

KE devices on a network which makes fine tuning the bandwidth, data throughput and video quality easier. Stackable switches can be configured to direct the KE transmissions between many units more specifically and effectively. Standalone switches provide the same configuration features as Stackable switches but they must be set individually.

Stackable switches provide an easy way to manage multiple switches, as one unit. For example, instead of configuring, managing, and troubleshooting 6 28-port switches individually, you can manage the six as if they are a single unit using Stackable Switches. The six switches (168 ports) function as a single switch and are managed from one web or GUI interface.

### **What Stackable Switches Can do:**

1. Create a link aggregation group with one port in one unit of the stack and another port of that group in another switch in the stack.
2. Select a port on one switch in the stack and mirror the traffic to a switch port on another unit of the stack; thus copy the configuration to direct traffic more effectively between KE devices.
3. Apply custom ACL security settings to any port on any switch in the stack.
4. Stackable switches can be setup in a ring configuration, so that if a port or cable fails, the stack automatically routes around the failure, at microsecond speeds. Stackable Switches also allow you to add and remove stack “members” which are automatically updated and recognized as such.

### **Switch Specifications**

The following specifications are recommended when choosing a layer 2 or layer 3 switch:

- ◆ 1000Mbps Gigabit Ethernet switches (1000Mbps or faster Ethernet ports)
- ◆ High bandwidth between switches, if possible using Fibre Channel
- ◆ Layer 3 switches that efficiently processes IGMP queries
- ◆ IGMP Snooping v2 or v3
- ◆ Flow Control Functions
- ◆ Throughput of: Full Duplex, 1Gbps up- and down- stream speeds per port
- ◆ Performance of their most onerous tasks (e.g. IGMP snooping) with multiple dedicated processors (ASICS)
- ◆ Use the same switch make and model throughout each subnet

- ◆ The maximum number of simultaneous ‘snooperable groups’ the switch can handle meets or exceeds the number of KE transmitters that will be used to create Channel groups

## **Configuring Switches and KE Devices**

Configuring the switch correctly will pass data more efficiently, allowing a better stream across the network to each KE device. The following settings will help optimize your network traffic through a switch:

- ◆ Enable IGMP Snooping on L2 switches
- ◆ Enable IGMP Querier on the L3 switch
- ◆ Enable IGMP Fast-Leave on all switches where KE units are directly connected
- ◆ Enable Spanning Tree Protocol (STP) on all switches and enable Portfast exclusively on switch ports that have KE units connected
- ◆ Pick an appropriate forwarding mode on all switches. Use Cut-through if available, or Store and Forward (see *Recommended Network Switches* below)

### **KE transmitter Settings:**

- ◆ Adjust the KE transmitter settings one at a time, in small intervals, and view the images as you do, so that you can adjust to the positive or negative results and achieve the best quality and bandwidth possible
- ◆ If the quality of color is important, set the Color Depth to 24 bits (KE69, KE89, KE99 Series) and manually adjust other settings until you are satisfied with the visual appearance
- ◆ If moving video images are shown frequently, increase the Video Quality setting to the highest level and reduce the Bandwidth Limit and Color Depth setting.
- ◆ When images on the screen are more often static, increase the Background Refresh and/or the Video Quality settings
- ◆ Check that all KE units have been updated with the latest firmware version

## **Recommended Network Switches**

Please refer to the FAQ link below on how to select network switches and network switch information collected by ATEN Customer Service Division, where the collected information includes customer's feedback from their actual experience in using and installing the product(s).

<https://eservice.aten.com/eServiceCx/Common/FAQ/view.do?id=6276>

---

## Additional Mouse Synchronization Procedures

---

If the mouse synchronization procedures mentioned in the manual fail to resolve mouse pointer problems for particular computers, try the following:

### Windows:

---

**Note:** In order for the local and remote mice to synchronize, you must use the generic mouse driver supplied with the MS operating system. If you have a third party driver installed - such as one supplied by the mouse manufacturer - you must remove it.

---

1. Windows 2000:
  - a) Open the Mouse Properties dialog box (Control Panel → Mouse → Mouse Properties)
  - b) Click the *Motion* tab
  - c) Bring the mouse speed to the middle position (6 units in from the left)
  - d) Set the mouse acceleration to *None*

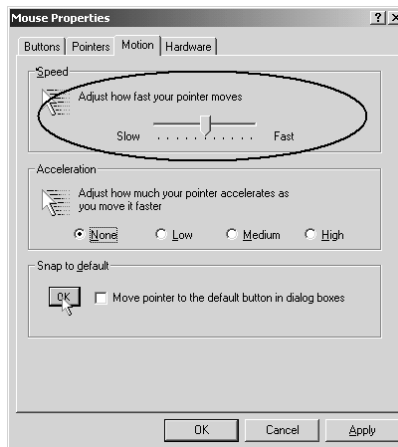

2. Windows XP / Windows Server 2003 / Windows 7 / Windows 8 / Windows 10:
  - a) Open the Mouse Properties dialog box (Control Panel → Mouse)  
(For Windows 10, click Start → Devices → Mouse → Additional mouse options)

- b) Click the *Pointer Options* tab
- c) Bring the mouse speed to the middle position (6 units in from the left)
- d) Disable *Enhance Pointer Precision*

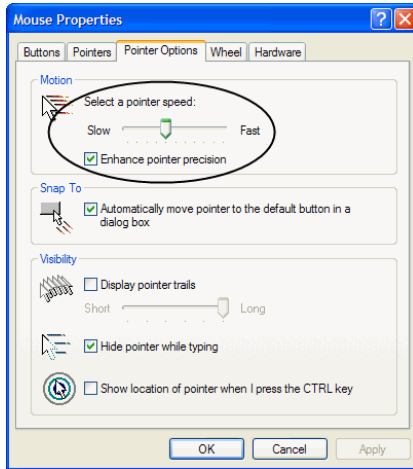

- 3. Windows ME:  
Set the mouse speed to the middle position; disable mouse acceleration (click **Advanced** to get the dialog box for this).
- 4. Windows NT / Windows 98 / Windows 95:  
Set the mouse speed to the slowest position.

### **Sun / Linux**

Open a terminal session and issue the following command:

Sun: `xset m 1`

Linux: `xset m 0`

or

`xset m 1`

(If one does not help, try the other.)

---

## Virtual Media Support

---

### WinClient ActiveX Viewer / WinClient AP

- ◆ IDE CDROM/DVD-ROM Drives – Read Only
- ◆ IDE Hard Drives – Read Only
- ◆ USB CDROM/DVD-ROM Drives – Read Only
- ◆ USB Hard Drives – Read/Write\*
- ◆ USB Flash Drives – Read/Write\*
- ◆ USB Floppy Drives – Read/Write

---

\* These drives can be mounted either as Drives or Removable Disks (see *Virtual Media*, page 193). Mounting them as removable disks allow booting the remote server if the disk contains a bootable OS. In addition, if the disk contains more than one partition, the remote server can access all the partitions.

---

- ◆ ISO Files – Read Only
- ◆ Folders – Read/Write
- ◆ Smart Card Readers

### Java Applet Viewer / Java Client AP

- ◆ ISO Files – Read Only
- ◆ Folders – Read/Write

---

**Note:** 1. The Java Client supports Virtual Media in the same way as WinClient does – however, the account should have Administrator level privilege.

2. Folder mapping uses a FAT16 file system, so there is a 2G limitation. Virtual Media only supports ISO files less than 4G.
-

## Setup CCKM Server IP address on Windows

---

1. Select **Network and Sharing Center** and click **Change adapter settings**.
2. Right-click **Local Area Connection** and select **Properties**.
3. In the Local Area Connection Properties window, highlight **Internet Protocol Version 4 (TCP/IPv4)** then click **Properties**.
4. Select **Use the following IP address** and enter in the IP for the CCKM server (e.g. any IP address not in use, and in between 192.168.0.2 and 192.168.0.253)\*, Subnet Mask (e.g. 255.255.255.0), and Default Gateway that corresponds with your network setup.
5. Click **OK** to change the CCKM server's IP address.

---

**Note:** Make sure the CCKM server's IP address is not a duplicate to prevent IP address conflict.

---

To connect to the CCKM server via web browser, enter the CCKM IP address and port number (default: 8443). For example, if the CCKM IP address is 192.168.0.10, then enter <https://192.168.0.10:8443>.

If you have a 2nd NIC, please follow the following steps.

6. Select **Network and Sharing Center** and click **Change adapter settings**.
7. Right-click **Local Area Connection** for the 2nd NIC and select **Properties**.
8. In the Local Area Connection Properties window, highlight **Internet Protocol Version 4 (TCP/IPv4)** then click **Properties**.
9. Select **Use the following IP address** and enter in the IP of the 2nd subnet for the CCKM server (e.g. any IP address not in use, and in between 192.168.1.2 and 192.168.1.253)\*, Subnet Mask (e.g. 255.255.255.0), and Default Gateway that corresponds with your network setup.
10. Click **OK** to change the CCKM server's IP address of the 2nd subnet.

## **ATEN Warranty Policy**

---

The warranty policy may vary by product category and region of purchase. For details, please visit ATEN's official website, select your purchase countries/regions and then go to the Support Center, or contact your local ATEN sales representative for further assistance.

© Copyright 2026 ATEN® International Co., Ltd.  
Released: 2026-05-22

ATEN and the ATEN logo are registered trademarks of ATEN International Co., Ltd. All rights reserved. All other brand names and trademarks are the registered property of their respective owners.