



Simply Better Connections

CL3708 / CL3716 / CL3708i CL3716i

8 / 16-Port USB HDMI Single Rail
WideScreen LCD KVM Switch
User Manual

Compliance Statements

FEDERAL COMMUNICATIONS COMMISSION INTERFERENCE STATEMENT

This equipment has been tested and found to comply with the limits for a Class A digital device, pursuant to Part 15 of the FCC Rules. These limits are designed to provide reasonable protection against harmful interference when the equipment is operated in a commercial environment. This equipment generates, uses, and can radiate radio frequency energy and, if not installed and used in accordance with the instruction manual, may cause harmful interference to radio communications. Operation of this equipment in a residential area is likely to cause harmful interference in which case the user will be required to correct the interference at his own expense.

The device complies with Part 15 of the FCC Rules. Operation is subject to the following two conditions: (1) this device may not cause harmful interference, and (2) this device must accept any interference received, including interference that may cause undesired operation.

FCC Caution

Any changes or modifications not expressly approved by the party responsible for compliance could void the user's authority to operate this equipment.

Warning

Operation of this equipment in a residential environment could cause radio interference.

Achtung

Der Gebrauch dieses Geräts in Wohnumgebung kann Funkstörungen verursachen.



KCC Statement

유선 제품용 / A 급 기기 (업무용 방송 통신 기기)
이 기기는 업무용 (A 급) 전자파적합기기로서 판매자 또는 사용자는 이 점을 주의하시기 바라며, 가정 외의 지역에서 사용하는 것을 목적으로 합니다.

Industry Canada Statement

This Class A digital apparatus complies with Canadian ICES-003.

CAN ICES (A) / NMB (A)**HDMI Trademark Statement**

The terms HDMI, HDMI High-Definition Multimedia Interface, HDMI trade dress and the HDMI Logo are trademarks or registered trademarks of HDMI Licensing Administrator, Inc.

**RoHS**

This product is RoHS compliant.

User Information

Online Registration

Be sure to register your product at our online support center:

International	http://eservice.aten.com
---------------	---

Telephone Support

For telephone support, call this number:

International	886-2-8692-6959
China	86-400-810-0-810
Japan	81-3-5615-5811
Korea	82-2-467-6789
North America	1-888-999-ATEN ext 4988 1-949-428-1111

User Notice

All information, documentation, and specifications contained in this manual are subject to change without prior notification by the manufacturer. The manufacturer makes no representations or warranties, either expressed or implied, with respect to the contents hereof and specifically disclaims any warranties as to merchantability or fitness for any particular purpose. Any of the manufacturer's software described in this manual is sold or licensed as *is*. Should the programs prove defective following their purchase, the buyer (and not the manufacturer, its distributor, or its dealer), assumes the entire cost of all necessary servicing, repair and any incidental or consequential damages resulting from any defect in the software.

The manufacturer of this system is not responsible for any radio and/or TV interference caused by unauthorized modifications to this device. It is the responsibility of the user to correct such interference.

The manufacturer is not responsible for any damage incurred in the operation of this system if the correct operational voltage setting was not selected prior to operation. PLEASE VERIFY THAT THE VOLTAGE SETTING IS CORRECT BEFORE USE.

A typical LCD (Liquid Crystal Display) monitor has millions of pixels. A dead pixel refers to a pixel with a defect in its ability to display the correct color output.

It most often looks like a tiny black or white spot on your screen, although it can be any other color. Since even a tiny dust particle on one of the pixels during the manufacturing process or a slight bump during shipping can create a dead pixel, the ISO 13406-2 norm defines 4 classes of acceptable screens with dead pixels--Class 1 is the best; Class 4 is the worst. Almost all manufacturers use Class 2 to establish their warranties, which allows a certain amount of dead pixels (ATEN allows up to 5 dead pixels) to exist before they will replace the screen. Since the manufacturers consider these screens to be acceptable under ISO specifications, we cannot be responsible for replacement or warranty of the TFT LCD panel.

Product Information

For information about all ATEN products and how they can help you connect without limits, visit ATEN on the Web or contact an ATEN Authorized Reseller. Visit ATEN on the Web for a list of locations and telephone numbers:

International	http://www.aten.com
North America	http://www.aten-usa.com

Package Contents

Check to make sure that all the components are in working order. If you encounter any problem, please contact your dealer.

CL3708 / CL3716

- ◆ 1 CL3708 / CL3716 8/16-Port USB HDMI Single Rail WideScreen LCD KVM Switch with Standard Rack Mount Kit
- ◆ 2 KVM cable sets
- ◆ 1 firmware upgrade cable
- ◆ 1 power cord
- ◆ 1 user instructions

CL3708i / CL3716i

- ◆ 1 CL3708i / CL3716i 1-Local/Remote Shared Access 8/16-Port USB HDMI Single Rail WideScreen FHD LCD KVM over IP Switch with Standard Rack Mount Kit
- ◆ 2 KVM cable sets
- ◆ 1 power cord
- ◆ 1 user instructions

Contents

Compliance Statements	ii
User Information	iv
Online Registration	iv
Telephone Support	iv
User Notice	iv
Product Information	v
Package Contents	vi
Contents	vii
About this Manual	xv
Applicable Models	xv
Usage of Terms	xvi
Document Overview	xvi
Conventions	xviii

Chapter 1. Introduction

Overview	1
CL3708 / CL3716	1
CL3708iNW / CL3716iNW	2
Features	4
CL3708 / CL3716	4
CL3708i / CL3716i	5
Requirements	7
Computers	7
External Console	7
Cables	7
Operating Systems	7
Components	8
Front View	8
CL3708 Rear View	9

Chapter 2. Hardware Setup

Overview	13
Before you Begin	13
Standard Rack Mount	14
Optional Rack Mount Kits	15
Grounding	15
Single-Level Installation	16
Cable Connection Diagrams	18
KVM Cable Installation Diagrams	18
Two-Level Installation (CL3708 / CL3716 only)	19

Chapter 3. Basic Operation

Opening the Console	21
Closing the Console	23
Operating Precautions	24
Powering Off and Restarting	25
Touchpad Operation	25
LCD OSD Configuration	26
The LCD Buttons	26
LCD Adjustment Settings	27
Hot Plugging	29
Hot Plugging KVM Ports	29
Port Selection	29
Pushbutton Port Switching	29
Port ID Numbering	30

Chapter 4. OSD Operation

OSD Overview	31
OSD Login	31
Dedicated Invocation Key	31
OSD Hotkey	31
OSD Main Screen (CL3708 / CL3716)	32
OSD Main Screen Headings	33
OSD Navigation	33
OSD Functions	34
F1: GOTO	34
F2: LIST	34
F3: SET	35
F4: ADM	38
Manufacturing Number	42
F5: SKP	42
F6: BRC	43
F7: AUTO SCAN	43
F8: LOUT	44
OSD Main Screen (CL3708i / CL3716i)	45
OSD Navigation	46
OSD Functions	46
F1: HELP	47
F3: SET	48
F4: ADM	50
F5: AUTO SCAN	50

Chapter 5. Keyboard Port Operation

Hotkey Port Control	53
Invoke Hotkey Mode	53

Dedicated Invocation Key	53
Number Lock and Minus Keys (CL3708 / CL3716 Only).	54
Control and F12 Keys (CL3708 / CL3716 Only)	54
Select the Active Port (CL3708 / CL3716 Only) 55	
Auto Scan Mode	55
Invoking Auto Scan:	55
Computer Keyboard / Mouse Reset (CL3708 / CL3716)	57
Hotkey Beeper Control	57
Quick Hotkey Control (CL3708 / CL3716 Only)	58
OSD Hotkey Control (CL3708 / CL3716 Only)	58
Port OS Control (CL3708 / CL3716 Only)	59
Hotkey Summary Table	60

Chapter 6.Super Administrator Setup

Overview (CL3708i / CL3716i Only)	61
First Time Setup	61
Network Setup	63
Changing the Super Administrator Login	64
Moving On.	65

Chapter 7.Logging In

Overview (CL3708i / CL3716i Only)	67
Browser Login	68
Windows Client AP Login	69
The Windows Client AP Connection Screen	70
Connecting – Windows Client AP	71
The File Menu	72
Java Client AP Login	73
The Java Client AP Connection Screen	74
Connecting – Java Client AP	75

Chapter 8.The User Interface

Overview (CL3708i / CL3716i Only)	77
The Web Browser Main Page	77
Page Components	78
User Settings	79
User Preferences	79
Change Password	82
Viewer Preference	82
Adjust Viewer Preference	83
The Tab Bar	83
The AP GUI Main Page	85
The Control Panel	87

WinClient Control Panel	87
WinClient Control Panel Functions	89
Video Settings	91
Network Bandwidth Information for KVM Sessions	93
Zoom	94
Mouse DynaSync Mode	95
Automatic Mouse Synchronization (DynaSync)	95
Mac and Linux Considerations	96
Manual Mouse Synchronization	96
The On-Screen Keyboard	97
Changing Languages	98
Resizing the Keyboard	98
Selecting Platforms	99
Expanded Keyboard	99
The Message Board	100
Button Bar	100
Message Display Panel	101
Compose Panel	101
User List Panel	101
More Control Panel Functions	103
Mouse Pointer Type	104
Customize Control Panel Configuration	105
The Java Control Panel	107
WebClient Control Panel	110

Chapter 9.Port Access

Overview (CL3708i / CL3716i Only)	113
Browser GUI	113
AP GUI	114
The Sidebar	115
The Sidebar Tree Structure	115
Scan	116
Array	116
Filter	116
Sidebar Utilities	118
Port Naming	119
KVM Devices and Ports – Connections Page	121
Device Level	121
Port Level	123
Status	123
Associated Links	123
History	124
Favorites	125
Adding a Favorite	125
Modifying a Favorite	127

Sessions	128
Access	129
Device Level Browser GUI Interface	129
Device Level AP GUI Interface	132
Port Level AP GUI Interface	134
Port Configuration	136
Device Level	136
Port Level	137
Port Properties	137
Associated Links	139

Chapter 10. User Management

Overview (CL3708i / CL3716i Only)	141
Browser GUI	141
AP GUI	142
Users	144
Adding Users	144
Device Assignment	150
Assigning Device Permissions From the User's Notebook	150
Filters	152
Assigning Device Permissions From the Groups' Notebook	153

Chapter 11. Device Management

KVM Devices (CL3708i / CL3716i Only)	155
Device Information	155
General	157
Operating Mode	157
Network	159
IP Installer	160
Service Ports	160
NIC Settings	161
Network Transfer Rate	162
Finishing Up	162
ANMS	163
Event Destination	163
Authentication	166
CC Management Settings	169
Security	170
Login Failures	170
Filter	172
Login String	175
Account Policy	175
Security Level	177
Working Mode	178

Host Header Validation	178
Private Certificate	179
Date/Time	181
Time Zone	181
Date	182
Network Time	182

Chapter 12.Log

Overview (CL3708i / CL3716i Only)	183
Browser GUI	183
AP GUI	184
Log Information	185
Log Notification Settings	188

Chapter 13.Maintenance

Overview (CL3708i / CL3716i Only)	189
Browser GUI	189
AP GUI	190
Main Firmware Upgrade	191
Recovering from Failed Firmware Upgrade	192
Update Display Info	193
Browser GUI	193
AP GUI	194
Backup/Restore	195
Backup	195
Restore	196
PingHost	197
Restore Values	198
Clear Port Names:	198
Restore Default Values:	198
Reset on exit:	198

Chapter 14.Download

Overview (CL3708i / CL3716i Only)	201
---	-----

Chapter 15.Port Operation

Overview (CL3708i / CL3716i Only)	203
Connecting to a Port	204
The Port Toolbar	206
The Toolbar Icons	207
Toolbar Hotkey Port Switching	208
Auto Scanning	208

Skip Mode	209
Recalling the Port Access Page	210
Panel Array Mode	211
Panel Array Toolbar	213
Multiuser Operation	214

Chapter 16. The Log Server

Installation (CL3708i / CL3716i Only)	215
Starting Up	216
The Menu Bar	217
Events	219
Search:	219
Maintenance:	220
Options	221
The Log Server Main Screen	222
Overview	222
The List Panel	222

Chapter 17. Keyboard Emulation

Mac Keyboard	225
Sun Keyboard	226

Chapter 18. The Firmware Upgrade Utility

Introduction (CL3708 / CL3716 Only)	227
Preparation	228
Starting the Upgrade	229
Upgrade Succeeded	231
Upgrade Failed	232

Appendix

Safety Instructions	233
General	233
Rack Mounting	235
Technical Support	236
International	236
Specifications	237
CL3708	237
CL3716	239
CL3708iNW / CL3716iNW	241
Maximum Number of Controlled Computers	244
CL3708	244
CL3716	245
.....	245

Clear Login Information	246
Supported KVM Switches	247
OSD Factory Default Settings	247
Troubleshooting	248
ATEN Warranty Policy	249

About this Manual

Applicable Models

This user manual is provided to help you get the most out of your USB HDMI Single Rail WideScreen LCD KVM Switch. It covers all aspects of the device, including installation, configuration, and operation.

This user manual covers the following USB HDMI Single Rail WideScreen LCD KVM Switch models:

Model	Product Name
CL3708NW	8-Port USB HDMI Single Rail WideScreen LCD KVM Switch with Standard Rack Mount Kit
CL3708NX	
CL3716NW	16-Port USB HDMI Single Rail WideScreen LCD KVM Switch with Standard Rack Mount Kit
CL3716NX	
CL3708iNW	1-Local/Remote Shared Access 8-Port USB HDMI Single Rail WideScreen FHD LCD KVM over IP Switch with Standard Rack Mount Kit
CL3716iNW	1-Local/Remote Shared Access 16-Port USB HDMI Single Rail WideScreen FHD LCD KVM over IP Switch with Standard Rack Mount Kit

Note:

These KVM switches are available in different LCD panel sizes and resolutions. The suffix letters appended to the model codes indicate the following specifications:

- ◆ N: 19" LCD panel
 - ◆ W: 1920 x 1080 resolution
 - ◆ X: 1366 x 768 resolution
-

Usage of Terms

Term	Description
<p><i>"USB HDMI Single Rail WideScreen LCD KVM Switch"</i></p> <p>or</p> <p><i>"CL3708 / CL3708i / CL3716 / CL3716i"</i></p>	<p>Refer to CL3708, CL3716, CL3708i, and CL3716i altogether, and all their variants (e.g. -NX, -NW, etc.).</p>

Document Overview

An overview of the information found in the manual is provided below.

Chapter 1, Introduction, introduces you to the CL3708 / CL3708i / CL3716 / CL3716i, its purpose, features, and benefits, with its front and back panel components described.

Chapter 2, Hardware Setup, describes how to set up your CL3708 / CL3708i / CL3716 / CL3716i, from the necessary steps for a basic single-level hookup to a complete 17-switch two-level operation.

Chapter 3, Basic Operation, explains the fundamental concepts involved in operating the CL3708 / CL3708i / CL3716 / CL3716i.

Chapter 4, OSD Operation, provides a complete description of the CL3708 / CL3708i / CL3716 / CL3716i OSD (on-screen display), and the various functions contained.

Chapter 5, Keyboard Port Operation, details all of the concepts and procedures involved in the hotkey operation of your CL3708 / CL3708i / CL3716 / CL3716i installation.

Chapter 6, Super Administrator Setup, explains the procedures that the super administrator employs in defining the KVM over IP switch's network environment and default login credentials.

Chapter 7, Logging In, describes how to log into the CL3708i / CL3716i via its Graphical User Interface (GUI) using different access methods: from the local console, via an Internet browser and a standalone Windows and/or Java application.

Chapter 8, The User Interface, describes the layout and components of the CL3708i / CL3716i's user interface.

Chapter 9, Port Access, describes the Port Access page and how to configure the various options provided for port management.

Chapter 10, User Management, shows administrators how to create, modify, and delete users, as well as assign access privileges.

Chapter 11, Device Management, shows administrators how to configure and control the overall CL3708i / CL3716i operations.

Chapter 12, Log, explains how to view, clear, and export event log information of the KVM over IP switch using the log file utility.

Chapter 13, Maintenance, explains how to upgrade the firmware of the CL3708i / CL3716i and the KVM adapters connected.

Chapter 14, Download, describes how to download standalone AP versions of the Win Client, the Java Client, and the Log Server programs.

Chapter 15, Port Operation, provides detailed information on accessing and operating the devices connected to the CL3708i / CL3716i's ports.

Chapter 16, The Log Server, explains how to install and configure the Log Server.

Chapter 17, Keyboard Emulation, provides tables that list the PC to Mac and PC to Sun keyboard emulation mappings.

Chapter 18, The Firmware Upgrade Utility, explains how to upgrade the CL3708 / CL3716's firmware to the latest available versions using the firmware upgrade utility.

Appendix, provides the specifications and other technical information at the end of the manual.

Note:

- ◆ Read this manual thoroughly and follow the installation and operation procedures carefully to prevent any damage to the unit or connected devices.
- ◆ The product may be updated with features and functions added, improved or removed since the release of this manual. For an up-to-date user manual, visit <http://www.aten.com/global/en/>

Conventions

This manual uses the following conventions:

- | | |
|---|--|
| Monospaced | Indicates text that you should key in. |
| [] | Indicates keys you should press. For example, [Enter] means to press the Enter key. If keys need to be chorded, they appear together in the same bracket with a plus sign between them: [Ctrl+Alt]. |
| 1. | Numbered lists represent procedures with sequential steps. |
| ◆ | Bullet lists provide information, but do not involve sequential steps. |
| > | Indicates selecting consecutive options (such as on a menu or dialog box). For example, Start > Run means to open the <i>Start</i> menu, and then select <i>Run</i> . |
|  | Indicates critical information. |

Chapter 1

Introduction

Overview

CL3708 / CL3716

The ATEN CL3708 / CL3716 is a space-efficient 1U single-rail LCD KVM switch designed for environments where space is limited, such as control rooms across various industries. Integrating an 18.5" LED-backlit widescreen monitor, full keyboard, and touchpad into a short-depth sliding housing, it provides reliable local access while maximizing valuable rack space.

Maximize Rack Space While Maintaining Clear Visibility

The CL3708 / CL3716 features a compact 1U single-rail chassis designed for shallow racks or other space-constrained environments. Its all-in-one design eliminates the need for external peripherals, and an integrated LED illumination light ensures clear visibility, supporting accurate operation even in dimly lit settings and around-the-clock use.

Centralized and Flexible Multi-System Control

Supporting direct USB and HDMI connections to 8 or 16 computers, the CL3708 / CL3716 can be cascaded up to two levels, enabling control of up to 128 or 256 computers. An external console output via USB and HDMI allows connection to a larger, higher-resolution monitor or a KVM extender* for remote console access, providing operational flexibility and efficiency.

Reliable Video Performance for Precise Monitoring

Engineered for dependable operation, the CL3708 / CL3716 delivers crisp video resolutions up to 1366 x 768 @ 60 Hz or 1920 x 1080 @ 60 Hz. Broadcast Mode enables commands to be sent to multiple computers simultaneously, while Auto Scan Mode provides continuous monitoring of selected systems, ensuring operators can monitor multiple systems efficiently and confidently.

Secure and Convenient System Management

Users can manage connected devices via front-panel pushbuttons, hotkeys, or a multilingual on-screen display (OSD). Two-level password protection safeguards against unauthorized access, and a dedicated, hot-pluggable USB mouse port (HID-only) on the front panel allows quick peripheral swaps, reducing downtime and improving convenience.

Note: Please refer to the Compatible Products section on the product page.

CL3708iNW / CL3716iNW

The ATEN CL3708i / CL3716i is a space-efficient 1U single-rail LCD KVM switch designed for mission-critical environments such as control rooms and data centers. Integrating an 18.5" LED-backlit widescreen monitor, full keyboard, and touchpad into a short-depth sliding housing, it delivers reliable local and over IP access while maximizing valuable rack space.

Maximize Rack Space While Maintaining Full Local Control

Built into a compact 1U single-rail chassis with a short-depth design, the CL3708i / CL3716i fits perfectly in shallow racks and space-constrained installations. The all-in-one console design eliminates the need for external peripherals, while an integrated LED illumination light ensures clear visibility for accurate operation in low-light, 24/7 environments.

Centralized and Flexible Control of Multiple Systems

Supporting direct USB and HDMI connections to 8 or 16 computers, the CL3708i / CL3716i enables efficient centralized management from a single console. An external USB and HDMI console output allows simultaneous local and external access, providing greater operational flexibility for multi-operator or extended workspace scenarios. System control is intuitive via front-panel pushbuttons, hotkeys, or a multilingual on-screen display (OSD). Broadcast Mode enables commands to be sent to multiple computers simultaneously, while Auto Scan Mode provides continuous monitoring of selected systems.

Crystal-Clear Full HD for Precise Monitoring

Engineered for reliable performance, the CL3708iNW / CL3716iNW delivers crisp Full HD 1920 x 1080 video at 60 Hz. This ensures clear and accurate visual output, helping operators monitor critical systems with confidence in mission-critical environments. In addition, the CL3708i / CL3716i features Panel Array Mode for simultaneous multi-server monitoring on a single screen, with each server displayed in an individual panel and customizable layouts for flexible viewing.

Simplified, Secure, and Efficient System Management

Three-level password protection safeguards against unauthorized access, a dedicated LAN port supports network-based firmware upgrades, and a front-panel hot-pluggable USB mouse port (HID-only) allows quick peripheral replacement to minimize downtime.

Features

CL3708 / CL3716

Space Utility Optimization

- ◆ Exclusive LED illumination light - designed by ATEN to illuminate the keyboard and touchpad to enhance usability in dimly lit settings
- ◆ Integrated LCD KVM console with an 18.5" LED-backlit widescreen LCD monitor in a single rail housing with top and bottom clearance for smooth operation in a 1U high system rack
- ◆ Short-depth design allows users to work with your rack-mounting equipment in narrow spaces
- ◆ Console lock - enables the console drawer to remain securely locked away in position when not in use

Reliability and Operational Versatility

- ◆ Superior video quality
 - ◆ Up to 1366 x 768 @ 60 Hz (CL3708NX / CL3716NX)
 - ◆ Up to 1920 x 1082 @ 60 Hz (CL3708NW / CL3716NW)
- ◆ Cascade up to 2 levels - CL3708 controls up to 128 computers or CL3716 controls up to 256 computers from a single console (With compatible KVM Switches¹)
- ◆ External console port - connect with a larger, higher-resolution monitor or pair with a KVM extender¹ to extend the console to a remote location for increased operational efficiency
- ◆ Computer selection via pushbuttons, hotkeys, and multilingual on-screen display (OSD)
- ◆ Broadcast mode - allows users to send commands from the console to all computers to perform operations simultaneously
- ◆ Two level password security - only authorized users can view and control computers
- ◆ Auto Scan mode - enables continuous monitoring of user-selected computers

- ◆ Keyboard Language supports: English (UK), English (US), German (GER.), German (SWISS.), French, Hungarian, Italian, Japanese, Korean, Russian, Spanish, Swedish and Traditional Chinese
- ◆ Additional hot-pluggable USB mouse port on front panel that supports HID device for keyboard and mouse

Installation Flexibility

- ◆ Standard rack mount kit included
- ◆ Optional rack mount kits available including easy installation options²
- ◆ No software required
- ◆ Firmware upgradable
- ◆ Supports hot-plugging

Note:

1. Please refer to the Compatible Products section on the product page.
 2. Contact your ATEN dealer for product information.
-

CL3708i / CL3716i

Space Utility Optimization

- ◆ Exclusive LED illumination light - designed by ATEN to illuminate the keyboard and touchpad to enhance usability in dimly lit settings
- ◆ Integrated LCD KVM console with an 18.5" LED-backlit widescreen LCD monitor in a single rail housing with top and bottom clearance for smooth operation in a 1U high system rack
- ◆ Short-depth design allows users to work with your rack-mounting equipment in narrow spaces
- ◆ Console lock - enables the console drawer to remain securely locked away in position when not in use

Reliability and Operational Versatility

- ◆ Superior video quality - up to 1920 x 1080 @ 60 Hz (CL3708iNW / CL3716iNW)

- ◆ External console port - manage computers in the LCD KVM switch from an external console (monitor, USB keyboard, and USB mouse)
- ◆ Computer selection via pushbuttons, hotkeys, and multilingual on-screen display (OSD)
- ◆ IP-based LCD KVM switch enabling local and remote shared access, allowing monitoring and control of multiple computers via a standard web browser over the network
- ◆ Broadcast mode - allows users to send commands from the console to all computers to perform operations simultaneously
- ◆ Three level password security - only authorized users can view and control computers
- ◆ Auto Scan mode - enables continuous monitoring of user-selected computers
- ◆ Panel Array Mode™ enables simultaneous monitoring of multiple servers on a single screen, with each server's video output displayed in an individual panel and configurable panel layouts for flexible viewing
- ◆ Keyboard Language supports: English (UK), English (US), German (GER.), German (SWISS.), French, Hungarian, Italian, Japanese, Korean, Russian, Spanish, Swedish and Traditional Chinese
- ◆ Additional hot-pluggable USB mouse port on front panel that supports HID device for keyboard and mouse

Installation Flexibility

- ◆ Standard rack mount kit included
- ◆ Optional rack mount kits available including easy installation options
- ◆ No software required
- ◆ Firmware upgradable via LAN port
- ◆ Supports hot-plugging

Note: Contact your ATEN dealer for product information.

Requirements

Computers

The following hardware components are required for each computer:

- ◆ An HDMI port
- ◆ A USB Type-B port

External Console

- ◆ An HDMI monitor capable of displaying the highest resolution provided by any computer in the installation
- ◆ USB keyboard and mouse

Cables

Substandard cables might damage or affect the overall performance of the connected devices. For optimum signal integrity and a simplified layout, please use the high-quality custom cable sets described below.

Function		Length	Part Number
Connecting a computer to the CL3708 / CL3708i / CL3716 / CL3716i	USB, HDMI	1.8 m	2L-7D02UH
	USB, HDMI, Audio*	3 m	2L-7D03UHX4

Note: The CL3708 / CL3708i / CL3716 / CL3716i is not equipped with audio ports.

Operating Systems

Supported operating systems include Windows, Mac, Linux, and Sun.

Components

Front View

Press the Exit/Light pushbutton for two seconds to turn the LED light ON or Off. (Default: On)

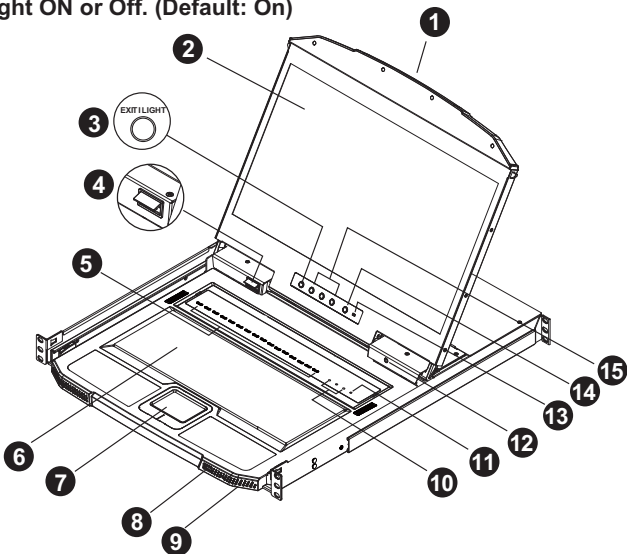

Note: A CL3716 / CL3716i is shown above for demonstration purposes. The illustrated hardware components are also applicable to the CL3708 / CL3708i, except that the CL3708 / CL3708i provides 8 ports.

CL3708 Rear View

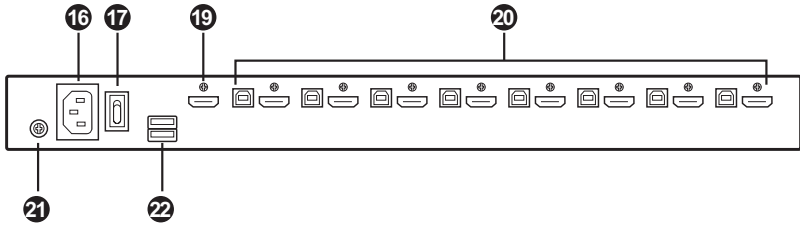

CL3708i Rear View

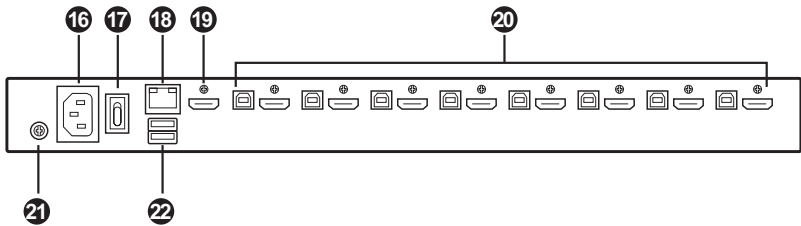

CL3716 Rear View

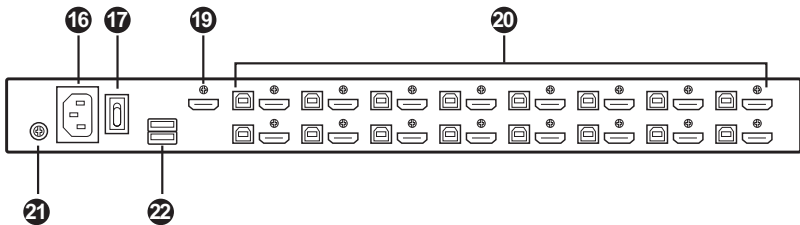

CL3716i Rear View

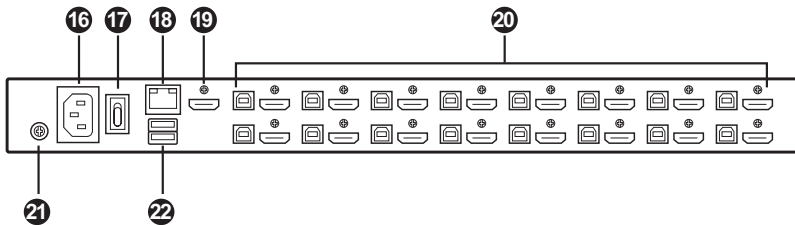

No.	Component	Description
1	handle	Pull to slide the LCD module out; push to slide it in. See <i>Opening the Console</i> , page 21 for sliding the console in and out.
2	LCD display	After sliding the KVM module out, flip up the cover to access the LCD monitor by pressing the Handle.
3	exit / light pushbutton	Press the exit / light pushbutton for two seconds to turn the LED light on or off (default: on). During the LCD OSD mode, this pushbutton has more functions. For more details, see <i>The LCD Buttons</i> , page 26.
4	LED illumination light	Illuminates the keyboard and touchpad to allow visibility in low-light conditions.
5	port selection pushbuttons / LEDs	Press the port pushbuttons to bring the KVM focus to the computer attached to the corresponding port. <ul style="list-style-type: none"> ◆ An orange ON LINE LED lights to indicate that the computer attached to its corresponding port is up and running. ◆ An orange ON LINE LED flashes to indicate that the corresponding port is being used for cascading to another switch ◆ A green Selected LED lights to indicate that the computer attached to the corresponding port is selected for KVM control

No.	Component	Description
6	keyboard	Standard 105-key keyboard.
7	touchpad	Standard mouse touchpad.
8	external mouse port	The USB port is available to connect a USB keyboard or mouse device for users who prefer to use an external keyboard and mouse.
9	power LED	Lights green to indicate that the unit is receiving power.
10	lock LEDs	The Num Lock, Caps Lock, Scroll Lock LEDs are located here.
11	reset button	<p>Located to the right of the Lock LEDs. Press this button in with a small object to perform a system reset.</p> <ul style="list-style-type: none"> ◆ Short press to perform a system reset. ◆ For CL3708iNW and CL3716iNW only: press the reset button for 10 seconds to perform a default reset. This is the same as the Clear Login Information (<i>Clear Login Information</i>, page 246).
12	firmware upgrade port	<p>The firmware upgrade cable that transfers the firmware upgrade data from the administrator's computer to the CL3708NX / CL3716NX plugs into this 3.5 mm audio jack.</p> <p>Note: For CL3708iNW / CL3716iNW, the firmware upgrade port is reserved for future expansion</p>
13	firmware upgrade switch	<p>During normal operation and while performing a firmware upgrade, this switch should be in the NORMAL position. If a firmware upgrade operation does not complete successfully, this switch is used to perform a firmware upgrade recovery. For more details, see <i>Upgrade Failed</i>, page 232.</p> <p>Note: For CL3708iNW / CL3716iNW, the firmware upgrade switch is reserved for future expansion.</p>

No.	Component	Description
14	LCD on / off button	<p>Push this button to turn the LCD monitor on and off. The button lights when the LCD monitor is off.</p> <p>Note: The light indicates that only the monitor is off, not the attached KVM switch.</p>
15	LCD controls	<p>The buttons to control the position and picture settings of the LCD display are located here. See <i>The LCD Buttons</i>, page 26, for details.</p>
16	power socket	<p>This is a standard 3-prong AC power socket. The power cord from an AC source plugs in here.</p>
17	power switch	<p>This standard rocker switch powers the unit on and off.</p>
18	LAN port (CL3708iNW / CK3716iNW only)	<p>The cable that connects the unit to network (10/100/1000 Mbps) plugs in here.</p>
19	HDMI out	<p>For flexibility and convenience, the CL3708NX / CL3708iNW / CL3716NX / CL3716iNW supports an independent, external console. The external console's HDMI display plugs in here.</p>
20	KVM ports section	<p>The provided KVM cable sets (USB and HDMI) that link to the computers plug in here.</p>
21	grounding terminal	<p>The grounding wire used to ground the switch attaches here.</p>
22	USB Type-A ports (keyboard / mouse)	<p>For flexibility and convenience, the CL3708NX / CL3708iNW / CL3716NX / CL3716iNW supports an independent, external console. The external console's USB keyboard and mouse plug in here.</p>

Chapter 2

Hardware Setup

Overview

The CL3708 / CL3708i / CL3716 / CL3716i is a switch designed to work with USB interface. It utilizes custom KVM cables that serve as the medium between the switch and managed computers. A custom KVM cable is required for each computer, and the available types are listed in *Cables*, page 7. Consult your dealer to find out which custom KVM cables best fit your needs.

Before you Begin



1. Important safety information regarding the placement of this device is provided on page 233. Please review it before proceeding.
2. Make sure that the power of all devices to be connected has been turned off. You must unplug the power cords of any computers with Keyboard Power-On function.
3. The LCD KVM switch is designed for rack mounting. If the KVM switch is not rack mounted, be sure to place it on a leveled and firm surface before pulling the device in or out to prevent damage due to uneven force on the module.

Place on Flat Surface

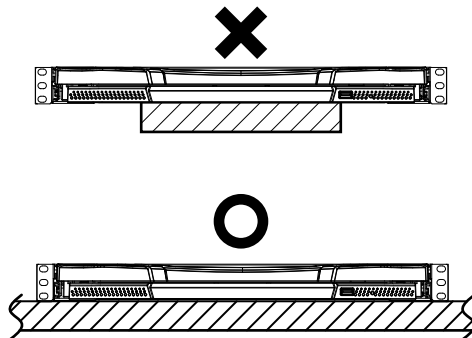



4. Please operate the device with caution when under high environmental temperatures, as the surface of the device may become overheated under such conditions. For instance, the surface temperature of the device may reach 70 °C or higher when the environmental temperature reaches close to 50 °C.

Standard Rack Mount

A standard rack mount kit is provided with your CL3708 / CL3708i / CL3716 / CL3716i, allowing it to be mounted in a 1U rack space. The kit enables the switch to be mounted onto a rack with a depth of 58.0 - 80.0 cm. The installation procedures are described in the following sections. Below is an image of the parts included with your package that will be needed for rack installation.

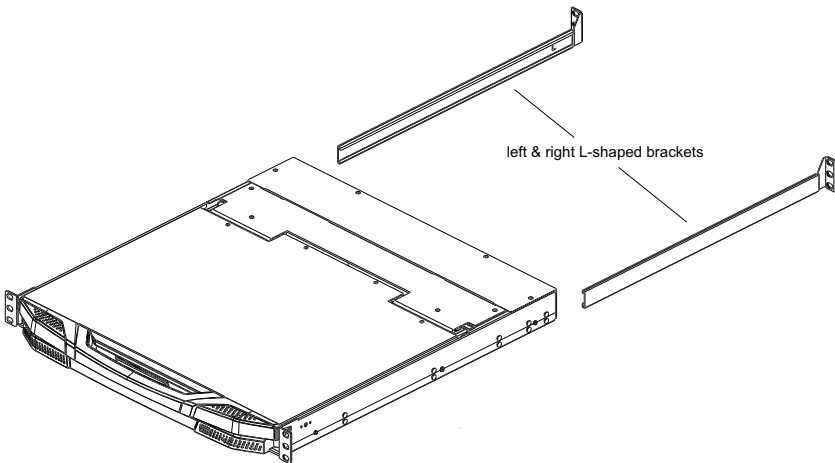

- Note:**
- ◆ It takes two people to mount the console.
 - ◆ The standard rack mount kit does not include screws or cage nuts. If you need additional screws or cage nuts, contact your rack dealer.

To rack mount the CL3708 / CL3708i / CL3716 / CL3716i, please refer to the LCD KVM Standard Rack Mount Installation Guide.

Optional Rack Mount Kits

Optional rack mount kits are also available and listed in the table below:

Mounting Kit	Description
Standard Long Rack Mount Kit	This kit is the long-railed version of your standard rack mount kit that lets you fit your device to racks with a greater depth.
Easy Installation Rack Mount Kit	This kit is designed to easily install the device without requiring more than one person

Note:

- ◆ For more information, visit the product webpage and refer to the *Compatible Accessories*. For detailed installation steps, visit the product webpage and refer to the *Optional Rack Mount Kits Installation Guide*.

Grounding

To prevent damage to your installation, it is important that all devices are properly grounded. Use a grounding wire to ground the CL3708 / CL3708i / CL3716 / CL3716i by connecting one end of the wire to the grounding terminal, and the other end of the wire to a suitable grounded object.

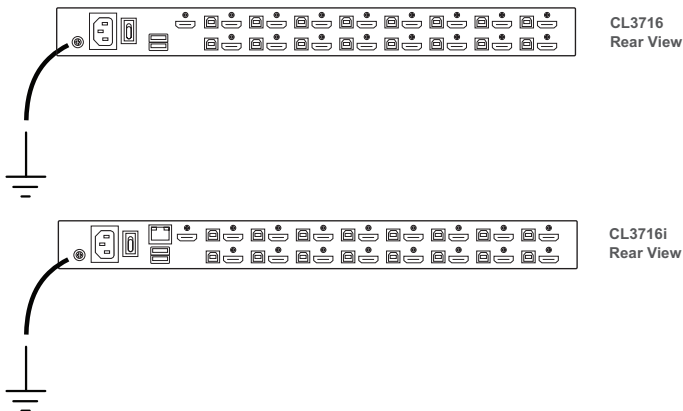

Note: The CL3716 / CL3716i is pictured above. The CL3708 / CL3708i rear panel is the same as the CL3716 / CL3716i, except that it has 8 KVM ports instead of 16.

Single-Level Installation

In a single-level installation, there are no additional switches cascaded from the first unit. To set up, do the following:

Note: The CL3716 / CL3716i is pictured below. The CL3708 / CL3708i rear panel is the same as the CL3716 / CL3716i, except that it has 8 KVM ports instead of 16.

1. Ground the CL3708 / CL3708i / CL3716 / CL3716i by connecting one end of a grounding wire to the grounding terminal and the other end to a suitable grounded object.

Note: Do not omit this step. Proper grounding helps prevent damage to the unit from power surges or static electricity.

2. (Optional) For external console operation, connect the unit's USB Type-A ports (keyboard / mouse) and HDMI output port to a USB keyboard, a USB mouse, and an HDMI-enabled monitor.
3. For each of the computers you are installing, use the provided KVM cable set (as described in *Cables*, page 7), to connect a KVM port to the computer's keyboard, video, and mouse ports. Refer to the *KVM Cable Installation Diagrams*, page 18.

Note: To purchase more KVM cable set, please contact your ATEN dealer for ordering information.

4. For CL3708i / CL3716i only, connect the unit's LAN port to a network switch for over-IP operation.
5. Plug the power cord into the CL3708 / CL3708i / CL3716 / CL3716i power socket and into an AC power source.
6. Use the power switch to power on the CL3708 / CL3708i / CL3716 / CL3716i and the power on the computers.

Single-Level Installation Diagram

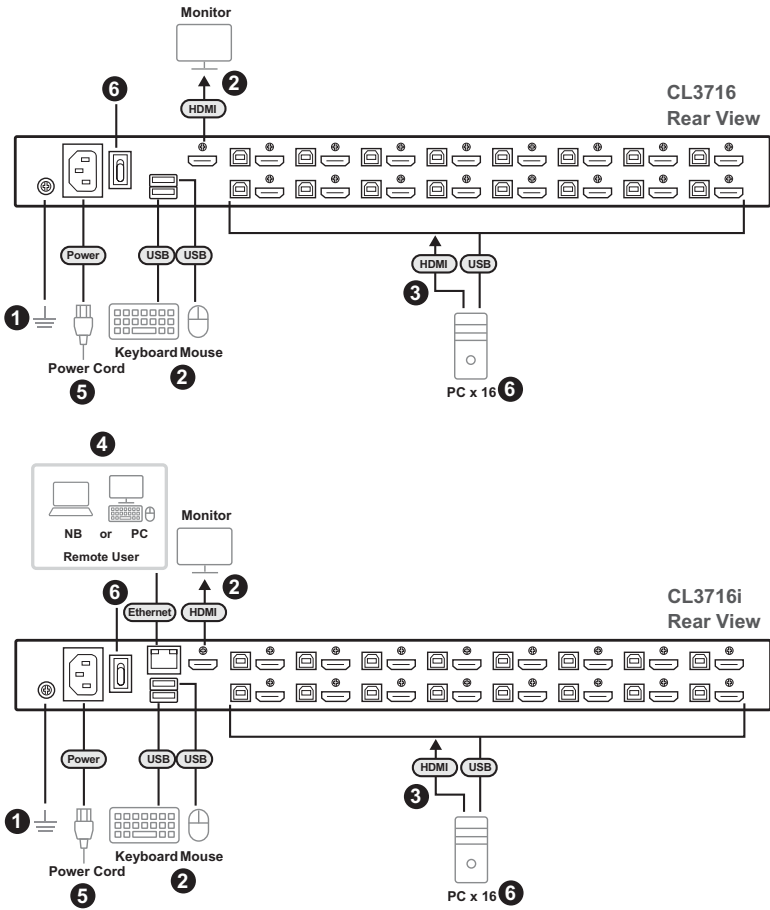

Cable Connection Diagrams

KVM Cable Installation Diagrams

USB KVM Cable Connection

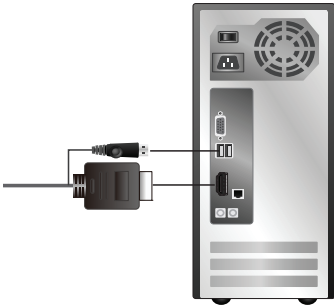

Two-Level Installation (CL3708 / CL3716 only)

To control even more computers, up to 8 / 16 additional switches can be cascaded from the first CL3708 / CL3716 (see the Appendix for a list of compatible ATEN switches). As many as 128 (CL3708) or 256 (CL3716) computers can be controlled from a single console in a complete cascaded installation. Tables showing the relation between the number of computers and the number of switches needed to control them are provided on page 244 in the Appendix.

To set up a two-level installation, do the following:

Note: The CL3716 is pictured below. The CL3708 rear panel is the same as the CL3716, except that it has 8 KVM ports instead of 16.

1. Ground the main switch — CL3708 / CL3716 and make sure that power has been turned off on all computers to be connected.
2. Using a KVM cable, connect any available KVM port on the first-level switch to the console port on the second level unit*.
3. Use KVM cable sets (*Cables*, page 7), to connect any available KVM port on the CL3708 / CL3716 installation to the keyboard, video, and mouse ports of the computers you are installing.
4. Repeat the above steps for any additional units you wish to add to the installation.
5. The Power-On sequence requires that all sub units to be powered on first. After they are all on, the main unit must be powered on next. Only after all the switches have been powered on in this sequence, can the computers be powered on.

Note: The CL3708 / CL3716 can only be installed as the first switch in a two-level installation as its LCD, keyboard, and mouse are used as the console and all second-level switches require an external console port to be cascaded.

Two-Level Installation Diagram

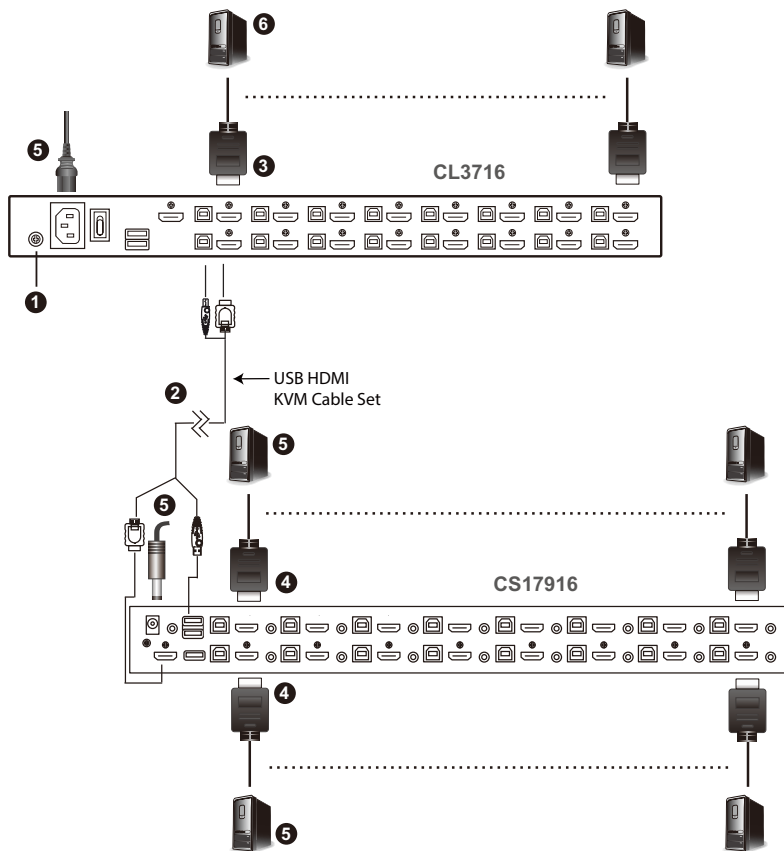

Chapter 3

Basic Operation

Opening the Console

The CL3708 / CL3708i / CL3716 / CL3716i's console is located under the top cover. To access the console, slide the console module out and raise the cover.

Note: As a safety precaution, to keep the console from accidentally sliding out, the console is locked into the In position. Before you can pull the console module out, you must release it by pulling the release bar on the unit's front panel toward the center of the switch.

To slide the console module out, do the following:

1. Pull on the release bar on the handle.

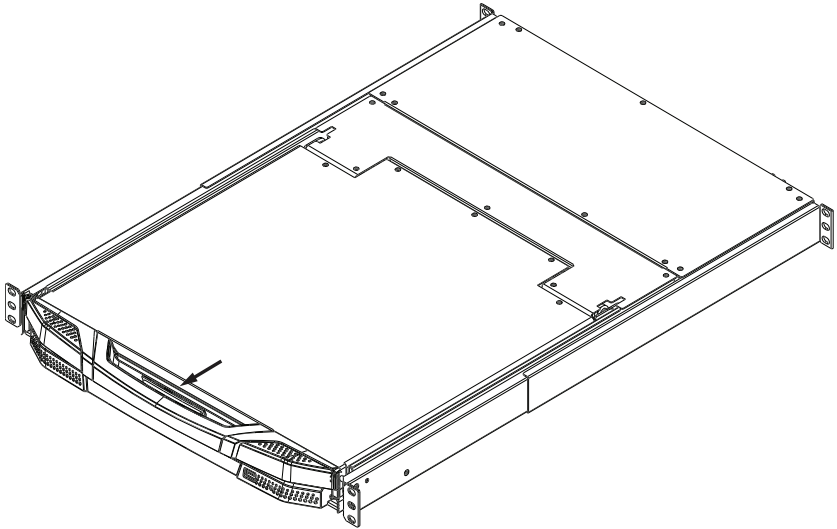

2. Slide the module all the way out until it automatically locks in place.

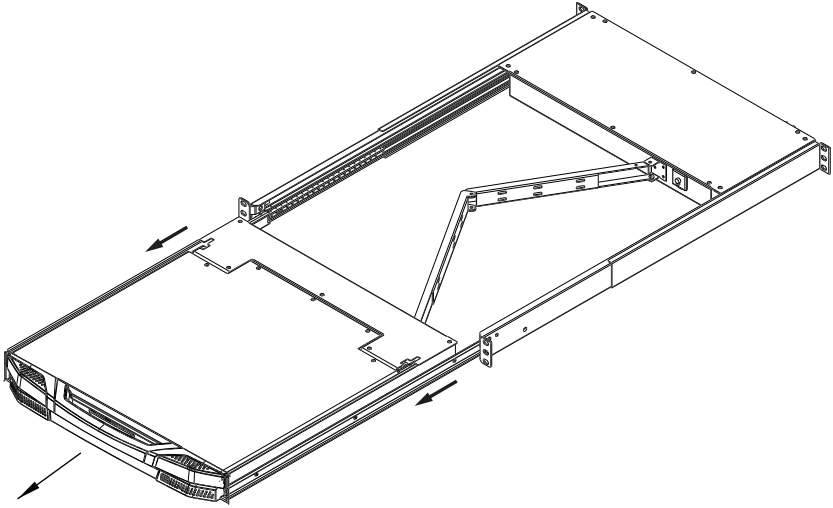

3. Open the cover by pulling the release bar on the handle as pictured below.

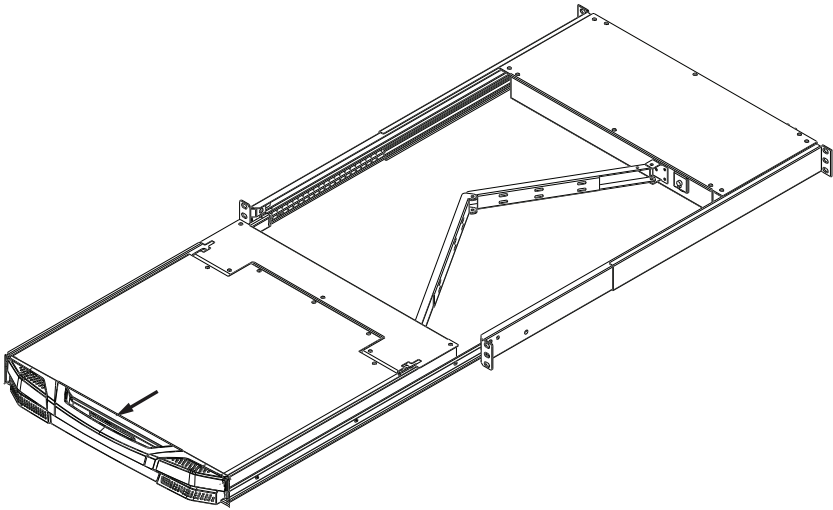

4. Below is what the CL3708 / CL3708i / CL3716 / CL3716i looks like when it is opened up.

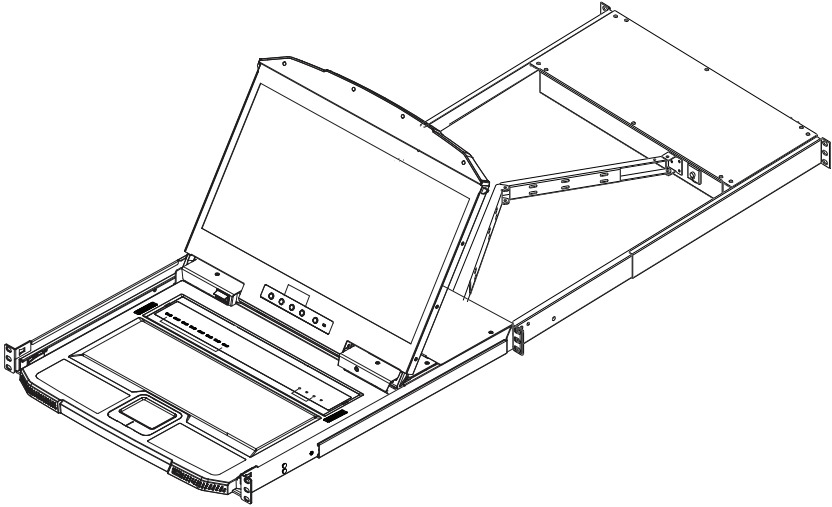

Closing the Console

To slide the console module back in, do the following:

1. Close the cover.
2. Push the module all the way in until it automatically locks in place.

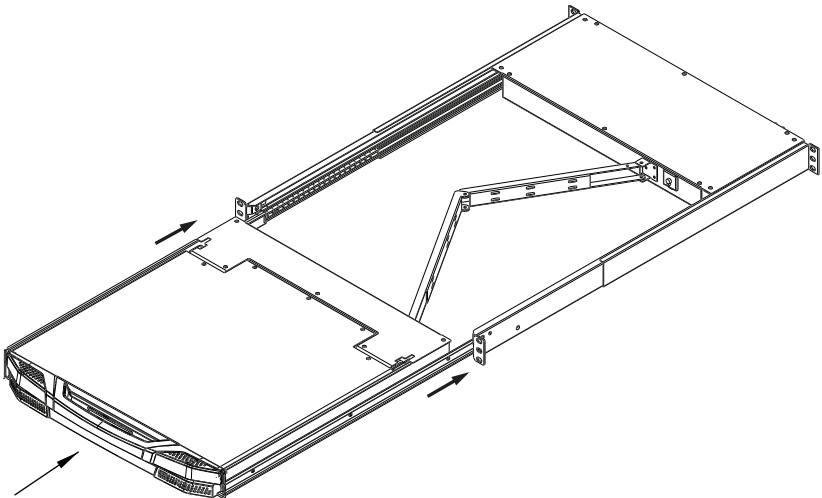

Operating Precautions

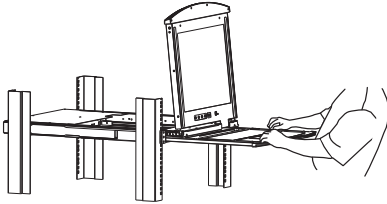
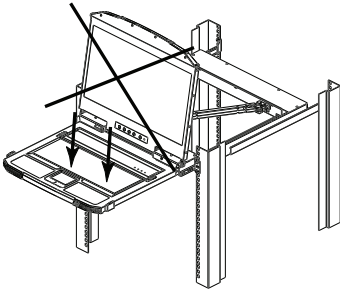

The maximum load bearing capacity of the keyboard module is 20 kg. Failure to heed the information below can result in damage to the keyboard module.

	<p>Right!</p> <p>Rest your hands and arms lightly on the keyboard module as you work.</p>
	<p>Wrong!</p> <ul style="list-style-type: none">◆ DO NOT lean your body weight on the keyboard module.◆ DO NOT place heavy objects on the keyboard module.

Powering Off and Restarting

If it becomes necessary to power off the CL3708 / CL3708i / CL3716 / CL3716i, do the following before restarting it:

1. Shut down all the computers that are attached to the CL3708 / CL3708i / CL3716 / CL3716i.

Note: Unplug the power cords of any computers with Keyboard Power-On function, otherwise, the CL3708 / CL3708i / CL3716 / CL3716i will still receive power from the computers.

2. Switch the CL3708 / CL3708i / CL3716 / CL3716i's power switch off.
3. Wait for 10 seconds, then switch the CL3708 / CL3708i / CL3716 / CL3716i' power switch back on.
4. After the CL3708 / CL3708i / CL3716 / CL3716i has turned on, power on the computers.

Note: If you have shut down more than one station, power up the highest station first and work your way down to the lowest one.



Touchpad Operation

Our touchpad supports two-finger scrolling operation that allows you to initiate scrolling on the touchpad with vertically movements. To do so, simply place two fingers down anywhere on the touchpad, and move them in a desired direction.

LCD OSD Configuration

The LCD Buttons

The LCD OSD allows you to set up and configure the LCD display. Four buttons are used to perform the configuration, as described in the table, below:

Button	Function
MENU	<ul style="list-style-type: none"> ◆ When you have not entered the LCD OSD Menu function, pressing this button invokes the Menu function, and brings up the Main Menu. ◆ When you have entered the LCD OSD Menu function, and have reached a setting choice with the navigation buttons, pressing this button brings up its adjustment screen.
	When navigating through the menus, this button moves you Right or Up. When making an adjustment, it increases the value.
	When navigating through the menus, this button moves you Left or Down. When making an adjustment, it decreases the value.
EXIT / LIGHT	<ul style="list-style-type: none"> ◆ When you have not entered the LCD OSD Menu function, pressing this button performs an auto adjustment. An auto adjustment automatically configures all the settings for the LCD panel to what the OSD considers their optimum values to be. ◆ When you have entered the LCD OSD Menu function, pressing this button exits the current menu and returns you to the previous menu. Use it to leave an adjustment menu when you are satisfied with the adjustment you made. ◆ When you are at the Main Menu, pressing this button exits the LCD OSD.
PANEL POWER	<ul style="list-style-type: none"> ◆ Push this button to turn the LCD monitor on and off. The button lights when the LCD monitor is off. <hr/> <p>Note: The light only indicates that the monitor is off, not the attached KVM switch.</p> <hr/>

LCD Adjustment Settings

An explanation of the LCD OSD adjustment settings is given in the table below:

Setting	Explanation
Brightness	Adjusts the background black level of the screen image.
Contrast	Adjusts the foreground white level of the screen image.
Phase	If pixel jitter or horizontal line noise is visible on the display, your LCD may have the wrong phase setting. Adjust the phase setting to eliminate these problems.
Clock	If vertical banding is visible on the display, your LCD may have the wrong clock setting. Adjust the clock setting to eliminate vertical banding.
H-Position	Positions the display area on the LCD panel horizontally (moves the display area left or right).
V-Position	Positions the display area on the LCD panel vertically (moves the display area up or down).
Color Temperature	Adjusts the color quality of the display. You can adjust the warmth value, color balance, etc. The <i>Adjust Color</i> selection has a further submenu that lets you fine tune the RGB values.
Language	Selects the language that the OSD displays its menus in.
OSD Duration	Lets you set the amount of time the OSD displays on the screen. If there is no input for the amount of time you choose, the OSD display turns off.
Reset	Resets the adjustments on all menus and submenus to their factory default settings.
	Note: The Language setting does not return to the factory default, but remains at the one that you have set it to.

Note: As an alternative to manually adjusting the LCD settings, you can have the LCD auto-adjusted for optimum display by pressing the Exit button. See *EXIT / LIGHT*, page 26.

Hot Plugging

The CL3708 / CL3708i / CL3716 / CL3716i supports *hot plugging* – components can be removed and added back into the installation by unplugging their cables from the ports without the need to shut the unit down. In order for hot plugging to work properly, the procedures described below must be followed.

Hot Plugging KVM Ports

In order for the OSD menus to correspond to KVM port changes, you must manually reconfigure the OSD to reflect the new port information. See the *F3 SET* (page 35) and *F4 ADM* (page 38), functions for details.

Note: If the computer's operating system does not support hot plugging, this function may not work properly.

Port Selection

The CL3708 / CL3708i / CL3716 / CL3716i provides three port selection methods to access the computers on the installation: Pushbutton, OSD (on-screen display), and Hotkeys. See Chapter 4, *OSD Operation* and Chapter 5, *Keyboard Port Operation* for more information.

Pushbutton Port Switching

Use the Port LED/Port Pushbuttons located on the keyboard module to switch KVM focus to any port on the installation.

Port ID Numbering

Each port on a CL3708 / CL3708i / CL3716 / CL3716i installation is assigned a unique *Port ID*. You can directly access any computer on any level of the installation by specifying the Port ID that the computer is connected to – either with the OSD (see *OSD Operation*, page 31), or with the Hotkey port selection method (see *Keyboard Port Operation*, page 53).

- ◆ A computer attached to the main unit has a two-digit Port ID (from 01–08 for the CL3708 / CL3708i; from 01–16 for the CL3716 / CL3716iCL3708 / CL3708i), that corresponds to the KVM port number that it is connected to.
- ◆ A computer attached to a sub unit has a four-digit Port ID.

The first two digits represent the KVM port number on the main and the second two digits represent the KVM port number on the slave unit that the computer is connected to. For example, a Port ID of 02–16 would refer to a computer that is connected to KVM port 16 of a slave unit that links back to KVM port 2 of the main unit.

Chapter 4

OSD Operation

OSD Overview

The on-screen display (OSD) is a mouse and keyboard enabled, menu-driven method to handle computer control and switching operations. All procedures start from the OSD main screen.

OSD Login

The OSD incorporates a two-level (administrator / user) password system. Before the OSD main screen displays, a login screen appears requiring a username and a password.

If this is the first time you are using the OSD, or if the password function has not been set, simply press **[Enter] [Enter]**. The OSD main screen is displayed under administrator mode, with full access to all functions, and can set up operations (including login credentials) as you like.

If the password function has been set, you must provide an appropriate administrator/user password in order to access the OSD.

Dedicated Invocation Key

A dedicated keys is provided on the keyboard module to make it easy to invoke the OSD (as shown in the diagram below):



Note: Press once to invoke the feature, press again to exit.

OSD Hotkey

The OSD hotkey is enabled and set to *[Scroll Lock]* *[Scroll Lock]* by default. Using the OSD hotkey, the users can access the OSD. You can change the Hotkey to the **[Ctrl]** key should you wish to. Refer to *Hotkey Summary Table* on page 60 for more information.

OSD Main Screen (CL3708 / CL3716)

When you invoke the OSD, a screen similar to the one below appears:

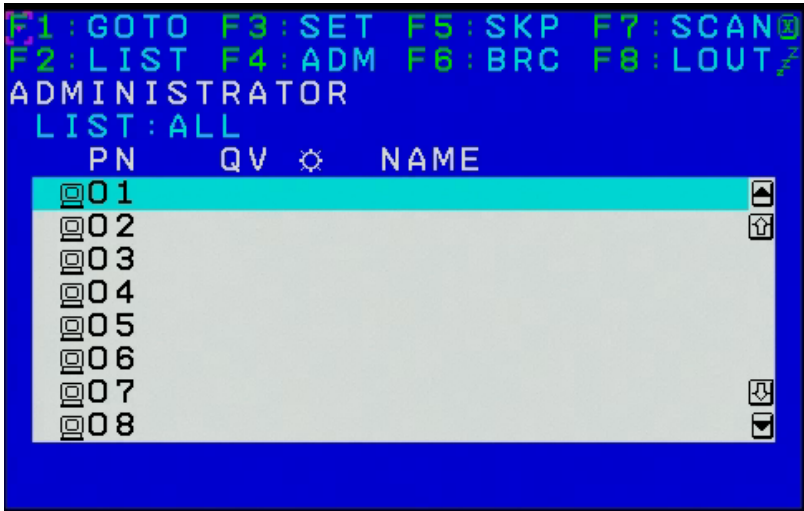

- Note:**
1. The diagram depicts the administrator's main screen. The user main screen does not show the F4 and F6 functions, since these are reserved for the administrator and can't be accessed by users.
 2. The OSD always starts in list view, with the highlight bar at the same position it was in the last time it was closed.
 3. Only the ports that have been set accessible by the administrator for the current logged in user are visible (see SET ACCESSIBLE PORTS, page 39, for details).
 4. If the port list is collapsed, click on a switch number, or move the highlight bar to it then press the right arrow key to expand the list. Similarly, to collapse a switch's port list, click on the switch number, or move the highlight bar to it then press the left arrow key to collapse the list.

OSD Main Screen Headings

The OSD main screen displays a table of the KVM ports and their corresponding settings. Refer to the table below for a description of each field.

Headings	Description
PN	This column lists the port ID numbers for all the KVM ports on the installation. The simplest method to access a particular computer is move the highlight bar to it, then press Enter .
QV	If a port has selected for quick view scanning (see <i>Set Quick View Ports</i> , page 41), an arrowhead displays in this column.
	The computers that are powered on and are online have a sun symbol in this column.
NAME	If a port has been given a name (see <i>Edit Port Names</i> , page 40), its name appears in this column.

OSD Navigation

- ◆ To dismiss the menu, and deactivate OSD, click the **X** at the upper right corner of the OSD window; or press **[Esc]**.
- ◆ To log out, click **F8** at the top of the main screen, or press **[F8]**.
- ◆ To move up or down through the list one line at a time, click the up and down triangle symbols (**▲▼**) or use the up and down arrow keys. If there are more list entries than what can appear on the main screen, the screen will scroll.
- ◆ To move up or down through the list one screen at a time, click the up and down arrow symbols (**↑↓**), or use the [Pg Up] and [Pg Dn] keys. If there are more list entries than what can appear on the main screen, the screen will scroll.
- ◆ To activate a port, double-click it, or move the highlight bar to it then press **[Enter]**.
- ◆ After executing any action, you automatically go back to the menu one level above.

OSD Functions

OSD functions are used to configure and control the OSD. For example, you can rapidly switch to any port, scan selected ports, limit the list you wish to view, designate a port as a quick view port, create or edit a port name, or make OSD setting adjustments.

To access an OSD function:

1. Either click a function key field at the top of the main screen, or press a function key on the keyboard.
2. In the submenus that appear make your choice either by double-clicking it, or moving the highlight bar to it, then pressing **[Enter]**.
3. Press **[Esc]** to return to the previous menu level.

F1: GOTO

Clicking the **F1** field or pressing **[F1]** activates the GOTO function. GOTO allows you to switch directly to a port either by keying in the port's *Name*, or its *Port ID*.

- ◆ To use the name method, key in **1**; key in the port's *Name*; then press **[Enter]**.
- ◆ To use the port ID method, key in **2**; key in the *Port ID*; then press **[Enter]**.

Note: You can key in a partial name or port ID. In that case, the screen will show all the computers that the user has View rights to (see SET ACCESSIBLE PORTS, page 39), that match the name or port ID pattern, regardless of the current list settings (see F2 LIST, page 34, for details).

To return to the OSD main screen without making a choice, press **[Esc]**.

F2: LIST

This function lets you broaden or narrow the scope of which ports the OSD displays on the main screen. The submenu choices and their meanings are given in the table below.

Choice	Meaning
ALL	Lists all of the ports on the installation that have been set accessible by the administrator for the current logged in user.
QUICK VIEW	Lists only the ports that have been selected as quick view ports (see <i>SET QUICK VIEW PORTS</i> , page 41).
POWERED ON	Lists only the ports that have their attached computers powered on.
QUICK VIEW + POWERED ON	Lists only the ports that have been selected as quick view ports (see <i>SET QUICK VIEW PORTS</i> , page 41), and that have their attached computers powered on.

Move the highlight bar to the choice you want, then press **[Enter]**. An icon appears before the choice to indicate that it is the currently selected one.

F3: SET

This function allows the administrator and each user to set up his own working environment. A separate profile for each is stored by the OSD and is activated according to the username that was provided during login.

To change a setting:

1. Double-click it; or move the highlight bar to it, then press **[Enter]**.
2. After you select an item, a submenu with further choices appears. To make a selection, either double-click it; or move the highlight bar to it, then press **[Enter]**. An icon appears before the selected choice to indicate which one it is. The settings are explained in the following table:

Setting	Function
OSD HOTKEY	<p>Selects one of the following to disable or enable a hotkey for activating the OSD function:</p> <p>OFF, [Scroll Lock] [Scroll Lock] or [Ctrl] [Ctrl].</p> <p>Note: By default, this function is set to <i>[Scroll Lock] [Scroll Lock]</i>.</p>
PORT ID DISPLAY POSITION	<p>Allows each user to customize the position where the port ID appears on the screen. The default is the upper left corner, but users can choose to have it appear anywhere on the screen.</p> <p>Use the mouse or the arrow keys plus Pg Up, Pg Dn, Home, End, and 5 (on the numeric keypad with Num Lock off), to position the port ID display, then double-click or press [Enter] to lock the position and return to the Set submenu.</p>
PORT ID DISPLAY DURATION	<p>Determines how long a port ID displays on the monitor after a port change has taken place. The choices are: 3 Seconds (default) and Always Off.</p>
PORT ID DISPLAY MODE	<p>Selects how the port ID is displayed: the port number plus the port name (PORT NUMBER + PORT NAME) (default); the port number alone (PORT NUMBER); or the port name alone (PORT NAME).</p>

SCAN DURATION	Determines how long the focus dwells on each port as it cycles through the selected ports in Auto Scan mode (see <i>F7 SCAN</i> , page 43). Key in a value from 1–255 seconds, then press [Enter] . Default is 5 seconds; a setting of 0 disables the SCAN function.
SCAN-SKIP MODE	<p>Selects which computers will be accessed under skip mode (see <i>F5 SKP</i>, page 42), and Auto Scan mode (see <i>F7 SCAN</i>, page 43. Choices are:</p> <p>ALL - All the ports which have been set accessible (see <i>SET ACCESSIBLE PORTS</i>, page 39);</p> <p>QUICK VIEW - Only those ports which have been set accessible and have been selected as quick view ports (see <i>SET QUICK VIEW PORTS</i>, page 41);</p> <p>POWERED ON - Only those ports which have been set accessible and are powered on;</p> <p>QUICK VIEW + POWERED ON - Only those ports which have been set accessible and have been selected as quick view ports and are powered on. The default is ALL.</p> <hr/> <p>Note:The quick view choices only show up on the administrator's screen, since only he has Quick View setting rights (see <i>SET QUICK VIEW PORTS</i>, page 41, for details).</p>
SCREEN BLANKER	If there is no input from the console for the amount of time set with this function, the screen is blanked. Key in a value from 1–30 minutes, then press [Enter] . The default setting of 0 disables this function.
HOTKEY COMMAND MODE	Enables / disables the hotkey command function in case a conflict with programs running on the computers occurs.
HOTKEY	Sets the keyboard shortcut for invoking <i>Hotkey Mode</i> (see page 53). Choices are: NUM LOCK + - (minus) (default), and CTRL + F12 .

OSD LANGUAGE	Sets the language used in the OSD. Choices are: English (default), German, Japanese, Simplified Chinese and Traditional Chinese.
TOUCHPAD	Enables / disables the touchpad function.

F4: ADM

F4 is an administrator only function. It allows the administrator to configure and control the overall operation of the OSD. To change a setting double-click it, or use the up and down arrow keys to move the highlight bar to it then press **[Enter]**.

After you select an item, a submenu with further choices to select from appears. Double-click an item, or move the highlight bar to it then press **[Enter]**. An icon appears before the selected item so that you know which one it is. The settings are explained in the following table:

Setting	Function
SET USER LOGIN	<p>This function is used to set usernames and passwords for the administrator and users:</p> <ol style="list-style-type: none"> 1. Usernames and passwords for one administrator and four users can be set. 2. After you select the administrator field or one of the user fields, a screen that allows you to key in the username and password appears. Usernames and passwords can be from 1 to 16 characters long and can consist of any combination of letters and numbers (A–Z, 0–9) and some additional keys (* () + : - , ? . / space). 3. For each individual, key in the username and password, confirm the password, then press [Enter]. 4. To modify or delete a previous username and/or password, use the backspace key to erase individual letters or numbers. Press [Enter] when done. <p>Note: Usernames and passwords are not case sensitive. Usernames are displayed in capital letters in the OSD.</p>

Setting	Function
SET ACCESSIBLE PORTS	<p>This function allows the administrator to define user access to the computers on the installation on a port-by-port basis.</p> <p>For each user, select the target port; then press the [Spacebar] to cycle through the choices: F (full access), V (view only), or blank. Repeat until all access rights have been set, then press [Enter]. The default is F for all users on all ports.</p> <hr/> <p>Note:</p> <ul style="list-style-type: none"> ◆ A blank setting means that no access rights are granted. The port will not show up on the user's LIST on the main screen. ◆ The administrator always has full access to all ports.
SET LOGOUT TIMEOUT	<p>If there is no input from the console for the amount of time set with this function, the user is automatically logged out. A login is necessary before the console can be used again.</p> <p>This enables other users to gain access to the computers when the original user is no longer accessing them, but has forgotten to log out. To set the timeout value, key in a number from 1–180 minutes, then press [Enter]. The default setting of 0 disables this function.</p> <hr/> <p>Note: This feature does not function if Set Login Mode is disabled. See <i>SET LOGIN MODE</i>, page 42.</p>

Setting	Function
EDIT PORT NAMES	<p>To help remember which computer is attached to a particular port, every port can be given a name. This function allows the administrator to create, modify, or delete port names.</p> <p>To edit a port name:</p> <ol style="list-style-type: none"> Click the port, or use the navigation keys to move the highlight bar to it, then press [Enter]. Key in the new port name, or modify/delete the old one. The maximum number of characters allowed for the port name is 12. Legal characters include: <ul style="list-style-type: none"> ◆ All alpha characters: A–Z ◆ All numeric characters: 0–9 ◆ * () + : - , ? . / and Space <p>Case does not matter; the OSD displays the port name in all capitals no matter how they were keyed in.</p> When you have finished editing, press [Enter] to have the change take effect. To abort the change, press [Esc].
RESTORE DEFAULT VALUES	<p>This function is used to undo all changes and return the setup to the original factory default settings (see <i>OSD FACTORY DEFAULT SETTINGS</i>, page 247) except for the port name list, username and password information, which are saved.</p>
CLEAR THE NAME LIST	<p>This function clears the port name list.</p>
ACTIVATE BEEPER	<p>Choices are Y (on), or N (off). When activated, the beeper sounds whenever a port is changed; when activating the Auto Scan function (see <i>F7 SCAN</i>, page 43); or an invalid entry is made on an OSD menu. The default is Y.</p>

Setting	Function
SET QUICK VIEW PORTS	<p>This function lets the administrator select which ports to include as quick view ports.</p> <ul style="list-style-type: none"> ◆ To select/deselect a port as a quick view port, double-click the port, or use the navigation keys to move the highlight bar to it, then press [Spacebar]. ◆ When a port has been selected as a quick view port, an icon displays in the QV column of the LIST on the main screen. When a port is deselected, the icon disappears. ◆ If one of the quick view options is chosen for the LIST view (see <i>F2 LIST</i>, page 34), only a port that has been selected here will display on the list. ◆ If one of the quick view options is chosen for auto-scanning (see <i>SCAN/SKIP MODE</i>, page 37), only a port that has been selected here will be auto-scanned. <p>The default has no ports selected for quick view.</p>
SET OPERATING SYSTEM	<p>This function allows the administrator to define the operating system for the computer connected to each KVM port. The default is WIN (PC compatible).</p> <p>To set the port operating system:</p> <ol style="list-style-type: none"> 1. From the list, select the port for which you wish to set the computer's operating system. 2. Set the operating system by pressing [Spacebar] to cycle through WIN, MAC, SUN, or OTHER. 3. Press [Esc] to exit. The operating system you selected is assigned to the KVM port.
FIRMWARE UPGRADE	<p>In order to upgrade the CL3708 / CL3708i / CL3716 / CL3716i firmware (see page 228), you must first enable Firmware Upgrade mode with this setting.</p> <p>When you bring up this menu, the current firmware version levels are displayed. Select Y to enable Firmware Upgrade mode, or N to leave this menu without enabling it.</p>
SET KEYBOARD LANGUAGE	<p>Sets the language for the computer keyboard attached to the KVM port. To select a keyboard language, double-click it, or use the navigation keys to move the highlight bar to it, then press [Enter].</p> <p>Choices are: AUTO (default), ENGLISH (UK), ENGLISH (US), GERMAN (GER.), GERMAN (SWISS), FRENCH, HUNGARIAN, ITALIAN, JAPANESE, KOREAN, RUSSIAN, SPANISH, SWEDISH, and TRADITIONAL CHINESE.</p>

Setting	Function
SET LOGIN MODE	This function allows the administrator to request users to login or not. When the login dialog box is disabled, the system disables the login/logout function. If the system is re-started, the login/logout function remains disabled.

Manufacturing Number

The “MFG Number” (Manufacturing Number) is an internal serial number used by ATEN’s factory and technical support staff to identify products. This number does not affect products’ warranty. If your product requires after-sales services, you may provide the MFG Number to ATEN’s sales or technical support staff to identify the product and model number. It can be found when you start firmware upgrade as in *FIRMWARE UPGRADE* on page 41.

F5: SKP

Clicking the **F5** field or pressing **[F5]** invokes Skip (SKP) mode. This function enables you to easily skip backward or forward – switching the console focus from the currently active computer port to the previous or next available one.

- ◆ The selection of computers to be available for skip mode switching is made with the *Scan–Skip* mode setting under the **F3: SET** function (see page 35).
- ◆ When you are in skip mode:
 - press [←] to switch to the previous computer in the list
 - press [→] to switch to the next computer in the list

Note: When you skip, you only skip to the previous or next available computer that is in the *Scan–Skip* mode selection (page 37).

- ◆ If a port has been selected for *Scan–Skip* mode, when the focus switches to that port a left/right triangle symbol appears before its port ID display.
- ◆ While skip mode is in effect, the console will not function normally. You must exit skip mode in order to regain control of the console.
- ◆ To exit skip mode, press **[Spacebar]** or **[Esc]**.

F6: BRC

F6 is an administrator only function. Clicking the **F6** field, or pressing **[F6]**, invokes *Broadcast* (BRC) mode. When this function is in effect, commands sent from the console are broadcast to all available computers on the installation.

This function is particularly useful for operations that need to be performed on multiple computers, such as performing a system wide shutdown, installing or upgrading software, etc.

- ◆ While BRC mode is in effect, a speaker symbol appears before the port ID display of the port that currently has the console focus.
- ◆ While BRC mode is in effect, the mouse will not function normally. You must exit BRC mode in order to regain control of the mouse.
- ◆ To exit BRC mode, invoke the OSD (with the OSD hotkey), then click the **F6** field, or press **[F6]**, to turn BRC mode off and the speaker symbol will disappear.

F7: AUTO SCAN

Clicking the **F7** field or pressing **[F7]** invokes *Auto Scan* mode. This function allows you to automatically switch among the available computers at regular intervals so that you can monitor their activity without having to take the trouble of switching yourself.

- ◆ The selection of computers to be included for auto-scanning is made with the *Scan-Skip* mode setting under the **F3: SET** function (see page 37).
- ◆ The amount of time that each port displays for is set with the *Scan Duration* setting under the **F3: SET** function (see page 36). When you want to stop at a particular location, press the [Spacebar] to stop scanning.
- ◆ If the scanning stops on an empty port, or one where the computer is attached but is powered Off, the monitor screen will be blank, and the mouse and keyboard will have no effect. After the *Scan Duration* time is up, the scan function will move on to the next port.
- ◆ As each computer is accessed, an **S** appears in front of the port ID display to indicate that it is being accessed under *Auto Scan* mode.
- ◆ While *Auto Scan* mode is in effect, the console will not function normally. You must exit *Auto Scan* mode in order to regain control of the console.

- ◆ While you are in *Auto Scan* mode, you can pause the scanning in order to keep the focus on a particular computer either by pressing **P**, or with a left-click of the mouse. See *Invoking Auto Scan*, page 55, for details.
- ◆ To exit *Auto Scan* mode, press the **[Spacebar]** or **[Esc]**.

F8: LOUT

Clicking the **F8** field, or pressing **[F8]** logs you out of OSD control of the computers, and blanks the console screen. This is different from simply pressing **[Esc]** when you are at the main screen to deactivate the OSD. With this function you must log in all over again to regain access to the OSD, whereas with **[Esc]**, all you have to do to reenter the OSD is tap the OSD hotkey.

-
- Note:**
1. When you reenter the OSD after logging out, the screen stays blank except for the OSD main screen. You must input your username and password before you can continue.
 2. If you reenter the OSD after logging out, and immediately use **[Esc]** to deactivate the OSD without having selected a port from the OSD menu, a null port message displays on the screen. The OSD hotkey will bring up the main OSD screen.
-

OSD Main Screen (CL3708i / CL3716i)

When you invoke the OSD, a screen similar to the one below appears:

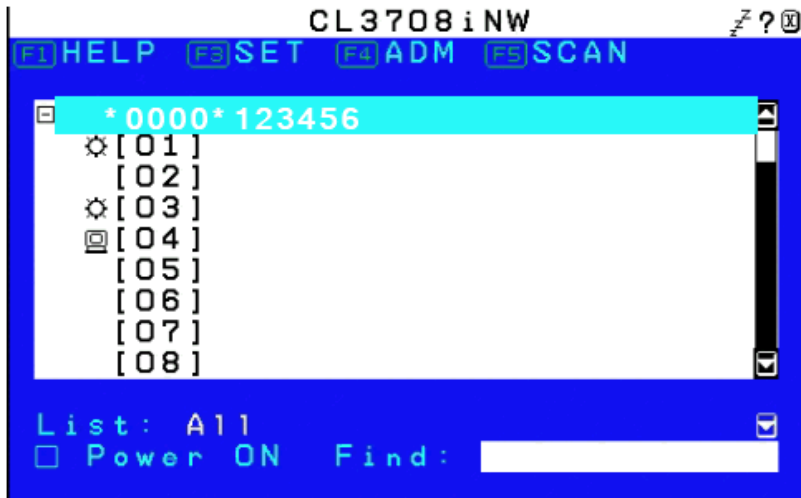

- Note:**
1. The diagram depicts the administrator's main screen. The user main screen does not show the F4 functions, since this is reserved for the administrator and can't be accessed by users.
 2. The OSD always starts in list view, with the highlight bar at the same position it was in the last time it was closed.
 3. Only the ports that have been set accessible by the administrator for the current logged in user are visible (see SET ACCESSIBLE PORTS, page 39, for details).
 4. If the port list is collapsed, click on a switch number, or move the highlight bar to it then press the right arrow key to expand the list. Similarly, to collapse a switch's port list, click on the switch number, or move the highlight bar to it then press the left arrow key to collapse the list.

OSD Navigation

- ◆ To dismiss the menu, and deactivate OSD, click the **X** at the upper right corner of the OSD window; or press **[Esc]**.
- ◆ To log out, press **[F8]**.
- ◆ To move up or down through the list one line at a time, click the up and down triangle symbols (**▲▼**) or use the up and down arrow keys. If there are more list entries than what can appear on the main screen, the screen will scroll.
- ◆ To activate a port, double-click it, or move the highlight bar to it then press **[Enter]**.
- ◆ After executing any action, you automatically go back to the menu one level above.

OSD Functions

OSD functions are used to configure and control the OSD. For example, you can rapidly switch to any port, scan selected ports, limit the list you wish to view, designate a port as a quick view port, create or edit a port name, or make OSD setting adjustments.

To access an OSD function:

1. Either click a function key field at the top of the main screen, or press a function key on the keyboard.
2. In the submenus that appear make your choice either by double-clicking it, or moving the highlight bar to it, then pressing **[Enter]**.
3. Press **[Esc]** to return to the previous menu level.

F1: HELP

This function shows you a list of supported function keys. The function keys and what they do are given in the table below.

Choice	Meaning
[F2]	<p>Navigate to a desire port and press [F2] to rename its port name.</p> <p>To help remember which computer is attached to a particular port, every port can be given a name. This function allows the administrator to create, modify, or delete port names.</p> <p>To edit a port name:</p> <ol style="list-style-type: none"> 1. Click the port, or use the navigation keys to move the highlight bar to it, then press [Enter]. 2. Key in the new port name, or modify/delete the old one. The maximum number of characters allowed for the port name is 12. Legal characters include: <ul style="list-style-type: none"> ◆ All alpha characters: A–Z ◆ All numeric characters: 0–9 ◆ * () + : - , ? . / and Space <p>Case does not matter; the OSD displays the port name in all capitals no matter how they were keyed in.</p> <p>When you have finished editing, press [Enter] to have the change take effect. To abort the change, press [Esc].</p>
[F7]	Closes the OSD.

Choice	Meaning
[F8]	<p>Logs you out of OSD control of the computers, and blanks the console screen. This is different from simply pressing [Esc] when you are at the main screen to deactivate the OSD. With this function you must log in all over again to regain access to the OSD, whereas with [Esc], all you have to do to reenter the OSD is tap the OSD hotkey.</p> <p>Note:</p> <ol style="list-style-type: none"> 1. When you reenter the OSD after logging out, the screen stays blank except for the OSD main screen. You must input your username and password before you can continue. 2. If you reenter the OSD after logging out, and immediately use [Esc] to deactivate the OSD without having selected a port from the OSD menu, a null port message displays on the screen. The OSD hotkey will bring up the main OSD screen.
[Ctrl] + [T]	Selects tree list.
[Ctrl] + [L]	Selects favorite ports.
[Ctrl] + [P]	Lists only the ports that have their attached computers powered on.
[Ctrl] + [F]	Searches port using port name.
[Ctrl] + [E]	Edits favorite ports.
[Ctrl] + [C]	Edits port properties between Share / Occupy / Exclusive.

Move the highlight bar to the choice you want, then press **[Enter]**. An icon appears before the choice to indicate that it is the currently selected one.

F3: SET

This function allows the administrator and each user to set up his own working environment. A separate profile for each is stored by the OSD and is activated according to the username that was provided during login.

To change a setting:

1. Double-click it; or move the highlight bar to it, then press **[Enter]**.
2. After you select an item, a submenu with further choices appears. To make a selection, either double-click it; or move the highlight bar to it, then press

[Enter]. An icon appears before the selected choice to indicate which one it is. The settings are explained in the following table:

Setting	Function
OSD HOTKEY	<p>Selects one of the following to disable or enable a hotkey for activating the OSD function:</p> <p>OFF, [Scroll Lock] [Scroll Lock] or [Ctrl] [Ctrl].</p> <p>Note: By default, this function is set to <i>[Scroll Lock] [Scroll Lock]</i>.</p>
SCAN DURATION	<p>Determines how long the focus dwells on each port as it cycles through the selected ports in Auto Scan mode (see <i>F7 SCAN</i>, page 43). Key in a value from 1–255 seconds, then press [Enter]. Default is 5 seconds; a setting of 0 disables the SCAN function.</p>
SCREEN BLANKER	<p>If there is no input from the console for the amount of time set with this function, the screen is blanked. Key in a value from 1–30 minutes, then press [Enter]. The default setting of 0 disables this function.</p>
SET LOGOUT TIMEOUT	<p>If there is no input from the console for the amount of time set with this function, the user is automatically logged out. A login is necessary before the console can be used again.</p> <p>This enables other users to gain access to the computers when the original user is no longer accessing them, but has forgotten to log out. To set the timeout value, key in a number from 1–180 minutes, then press [Enter]. The default setting of 0 disables this function.</p> <p>Note: This feature does not function if Set Login Mode is disabled. See <i>SET LOGIN MODE</i>, page 42.</p>
ACTIVATE BEEPER	<p>Choices are on or off. When activated, the beeper sounds whenever a port is changed; when activating the Auto Scan function (see <i>F7 SCAN</i>, page 43); or an invalid entry is made on an OSD menu. The default is on.</p>

F4: ADM

F4 is an administrator only function. It allows the administrator to configure and control the overall operation of the OSD. To change a setting double-click it, or use the up and down arrow keys to move the highlight bar to it then press **[Enter]**.

After you select an item, a submenu with further choices to select from appears. Double-click an item, or move the highlight bar to it then press **[Enter]**. An icon appears before the selected item so that you know which one it is. The settings are explained in the following table:

Setting	Function
Device Information	Shows device information such as device name, MAC address, firmware version, IP address, subnet mask, IPv6 address, and IPv6 subnet prefix length.
Set IP Address	Sets the IP address, the choices are obtain IP address automatically (DHCP) or Static IP which means you can set a preferred IP address, subnet mask, and default gateway.
Keyboard / Mouse Broadcast	Sets the keyboard and mouse broadcast on or off.
Disable Dev Authentication	Disables or enables the Dev authentication.
Clear Port Names	This function clears the port name list.
Reset Default Values	This function is used to undo all changes and return the setup to the original factory default settings (see <i>OSD FACTORY DEFAULT SETTINGS</i> , page 247) except for the port name list, username and password information, which are saved.
Reset on Exit	Enables disables reset on exit function. When its enabled, the CL3708i / CL3716i performs a rest when you exit the OSD.

F5: AUTO SCAN

Clicking the **F5** field or pressing **[F5]** invokes *Auto Scan* mode. This function allows you to automatically switch among the available computers at regular intervals so that you can monitor their activity without having to take the trouble of switching yourself.

- ◆ If the scanning stops on an empty port, or one where the computer is attached but is powered Off, the monitor screen will be blank, and the mouse and keyboard will have no effect. After the *Scan Duration* time is up, the scan function will move on to the next port.
- ◆ As each computer is accessed, an **S** appears in front of the port ID display to indicate that it is being accessed under *Auto Scan* mode.
- ◆ While *Auto Scan* mode is in effect, the console will not function normally. You must exit *Auto Scan* mode in order to regain control of the console.
- ◆ While you are in *Auto Scan* mode, you can pause the scanning in order to keep the focus on a particular computer either by pressing **P**, or with a left-click of the mouse. See *Invoking Auto Scan*, page 55, for details.
- ◆ To exit *Auto Scan* mode, press the **[Spacebar]** or **[Esc]**.

Chapter 5

Keyboard Port Operation

Hotkey Port Control

Hotkey port control allows you to provide KVM focus to a particular computer directly from the keyboard. The CL3708 / CL3708i / CL3716 / CL3716i provides the following hotkey port control features:

- ◆ Selecting the Active Port (CL3708 / CL3716 only)
- ◆ Auto Scan Mode Switching
- ◆ Computer Keyboard / Mouse Reset (CL3708 / CL3716 only)

The following settings can also be controlled in *Hotkey* mode:

- ◆ Setting the Beeper
- ◆ Setting the Quick Hotkey (CL3708 / CL3716 only)
- ◆ Setting the OSD Hotkey (CL3708 / CL3716 only)
- ◆ Setting the Port Operating System (CL3708 / CL3716 only)

Invoke Hotkey Mode

All hotkey operations begin by invoking *Hotkey* mode. There are two possible keystroke sequences used to invoke *Hotkey* mode, though only one can be operational at any given time.

Note: Make sure that the *Hotkey Command Mode* function is enabled and that you key in the appropriate *Hotkey*. See page 37 for details.

Dedicated Invocation Key

A dedicated key is provided on the keyboard module to make it easy to invoke the Hotkey Mode (as shown in the diagram below):



Note: Press once to invoke the feature; press again to exit.

Number Lock and Minus Keys (CL3708 / CL3716 Only)

1. Hold down the **Num Lock** key;
2. Press and release the **minus** key;
3. Release the **Num Lock** key:

[Num Lock] + [-]

Control and F12 Keys (CL3708 / CL3716 Only)

1. Hold down the **Ctrl** key;
2. Press and release the **F12** key;
3. Release the **Ctrl** key:

[Ctrl] + [F12]

When *Hotkey* mode is active:

- ◆ A command line appears on the monitor screen. The command line prompt is the word *Hotkey*: in white text on a blue background, and displays the subsequent hotkey information that you key in.
- ◆ Ordinary keyboard and mouse functions are suspended – only hotkey compliant keystrokes (described in the sections that follow), can be input.

Pressing [**Esc**] exits *Hotkey* mode.

Select the Active Port (CL3708 / CL3716 Only)

Each KVM port is assigned a port ID (see *Port ID Numbering*, page 30). You can directly access any computer on the installation with a hotkey combination that specifies the port ID of the KVM port that a computer is connected to. To access a computer using hotkeys:

1. Invoke hotkey mode with the **[Num Lock] + [-]** or **[Ctrl] + [F12]** combination.
2. Key in the port ID.
The port ID numbers display on the command line as you key them in. If you make a mistake, use **[Backspace]** to erase the wrong number.
3. Press **[Enter]**.
After you press **[Enter]**, the KVM focus switches to the designated computer and you automatically exit hotkey mode.

Note: In hotkey mode, KVM focus will not switch to a port if an invalid switch or port number is entered. The hotkey command line will continue to display on the screen until you enter a valid switch and port number combination, or exit hotkey mode.

Auto Scan Mode

Auto Scan automatically switches, at regular intervals, among all the KVM ports that have been set as accessible under *Scan–Skip Mode*, so that their activity can be monitored automatically. See *Scan–Skip Mode* on page 37 for more information.

Invoking Auto Scan:

To start *Auto Scan*, key in the following Hotkey combination:

1. CL3708 / CL3716: Invoke hotkey mode with the **[Num Lock] + [-]** or **[Ctrl] + [F12]** combination.
CL3708i / CL3716i: Use the dedicated key provided on the keyboard module to invoke the Hotkey Mode. See *Dedicated Invocation Key*, page 53.
2. Press **[A]**. After you press **A**, then **[Enter]**, you automatically exit hotkey mode, and enter *Auto Scan* mode.

- ◆ While you are in *Auto Scan* mode, you can pause the scanning in order to keep the focus on a particular computer either by pressing **P** or with a left click of the mouse. During the time that auto-scanning is paused, the command line displays: **Auto Scan: Paused**.

Pausing when you want to keep the focus on a particular computer is more convenient than exiting *Auto Scan* mode because when you resume scanning, you start from where you left off. If, on the other hand, you exited and restarted, scanning would start over from the very first computer on the installation.

To resume Auto Scanning, press any key or left-click. Scanning continues from where it left off.

- ◆ While *Auto Scan* mode is in effect, ordinary keyboard and mouse functions are suspended – only *Auto Scan* mode compliant keystrokes and mouse clicks can be input. You must exit *Auto Scan* mode in order to regain normal control of the console.

Note: Auto Scan duration could be adjusted via OSD menu.

3. To exit *Auto Scan* mode press **[Esc]** or **[Spacebar]**. Auto-scanning stops when you exit *Auto Scan* mode.

Computer Keyboard / Mouse Reset (CL3708 / CL3716)

If the keyboard or mouse cease to function on the computer connected to the currently selected port, you can perform a keyboard / mouse reset on the computer. This function is essentially the same as unplugging and replugging the keyboard and mouse on the target computer. To perform a computer keyboard / mouse reset, key in the following hotkey combination:

1. Invoke hotkey mode with the **[Num Lock] + [-]** or **[Ctrl] + [F12]** combination.
2. Press **[F5]**.

After you press [F5] you automatically exit *Hotkey* mode and regain keyboard and mouse control on the computer connected to the KVM port. If you fail to regain keyboard / mouse control on the computer after pressing [F5], perform a console keyboard and mouse reset. For more information, see *port selection pushbuttons / LEDs*, page 10.

Hotkey Beeper Control

The beeper (see *Activate Beeper*, page 40) can be hotkey toggled on and off. To toggle the beeper, key in the following hotkey combination:

1. CL3708 / CL3716: Invoke hotkey mode with the **[Num Lock] + [-]** or **[Ctrl] + [F12]** combination.

CL3708i / CL3716i: Use the dedicated key provided on the keyboard module to invoke the Hotkey Mode. See *Dedicated Invocation Key*, page 53.

2. Press **[B]**.

After you press [B], the beeper toggles on or off. The command line displays *Beeper On* or *Beeper Off* for one second; then the message disappears and you automatically exit hotkey mode.

Quick Hotkey Control (CL3708 / CL3716 Only)

The *Quick Hotkey* (see *HOTKEY*, page 37) can be toggled between [Num Lock] + [-], and [Ctrl] + [F12]. To toggle the *Quick Hotkey*:

1. Invoke hotkey mode with the **[Num Lock] + [-]** or **[Ctrl] + [F12]** combination.
2. Press **[H]**.

After you press [H], the command line displays *HOTKEY HAS BEEN CHANGED* for one second; then the message disappears and you automatically exit *Hotkey* mode.

OSD Hotkey Control (CL3708 / CL3716 Only)

The *OSD hotkey* (see *OSD HOTKEY*, page 35) can be toggled between OFF, [Scroll Lock] [Scroll Lock], or [Ctrl] [Ctrl]. To toggle the *OSD Hotkey*, key in the following hotkey combination:

1. Invoke hotkey mode with the **[Num Lock] + [-]** or **[Ctrl] + [F12]** combination.
2. Press **[T]**.

After you press [T], the command line displays *HOTKEY HAS BEEN CHANGED* for one second; then the message disappears and you automatically exit *Hotkey* mode.

Port OS Control (CL3708 / CL3716 Only)

A port's operating system can be changed to match that of the computer attached to the port. To change a port's operating system, key in the following hotkey combination:

1. Invoke hotkey mode with the **[Num Lock] + [-]** or **[Ctrl] + [F12]** combination.
2. Key in **[Function]**, where [Function] refers to one of the function keys in the following table:

Key	Description
F1	Sets the Port OS to Windows
F2	Sets the Port OS to Mac
F3	Sets the Port OS to Sun

After pressing a function key you automatically exit *Hotkey* mode.

Hotkey Summary Table

Invoke HSM	Hotkey	Action
[Scroll] + [Scroll]	[ScrollLock] [ScrollLock]	Activates OSD mode. Tap [Esc] to close the OSD and go back to the normal PC operation.
[Num Lock] + [-] or [Ctrl] + [F12]	[A] / [a] [Enter]	Invokes <i>Auto Scan</i> mode. The KVM focus cycles from port to port at 5-second intervals. Auto Scan duration could be adjusted via OSD menu. When <i>Auto Scan</i> mode is in effect, [P] or left-click pauses auto-scanning. When auto-scanning is paused, pressing any key or another left-click resumes auto-scanning.
	[Port ID] [Enter] (CL3708 / CL3716 Only)	Switches access to the computer that corresponds to that Port ID (CL3708: 01-08; CL3716: 01-16).
	[B]	Toggles the beeper on or off. (Default Setting is On)
	[Esc] or [Spacebar]	Exits hotkey mode or to quit the Setting Mode.
	[F1] (CL3708 / CL3716 Only)	Set Windows keyboard emulation. (Default Setting)
	[F2] (CL3708 / CL3716 Only)	Set Mac keyboard emulation.
	[F3] (CL3708 / CL3716 Only)	Set Sun keyboard emulation.
	[F5] (CL3708 / CL3716 Only)	Performs a keyboard / mouse reset on the target computer.
	[H] / [h] (CL3708NX / CL3716NX Only)	Toggles the <i>Quick Hotkey</i> invocation keys between [Ctrl] + [F12] and [Num Lock] + [-].
	[T] / [t] (CL3708NX / CL3716NX Only)	Toggles the <i>OSD hotkey</i> between OFF, [Ctrl] [Ctrl], or [Scroll Lock] [Scroll Lock].

Chapter 6

Super Administrator Setup

Overview (CL3708i / CL3716i Only)

This chapter discusses the administrative procedures that the Super Administrator performs to get the LCD KVM over IP switch set up for the first time.

First Time Setup

Once the LCD KVM over IP switch has been cabled up, the Super Administrator needs to set the unit up for user operation. This involves setting the network parameters, and changing the default Super Administrator login. The most convenient way to do this for the first time is from the remote console.

1. Open the browser and specify the IP address of the switch you want to access in the browser's location bar.

Note: For security purposes, a login string may have been set by the administrator (see page 175 for details). By default, there is no login string. If so, you must include a forward slash and the login string along with the IP address when you log in. For example:

192.168.0.100/k111116v

If you don't know the IP address and login string, ask your Administrator.

2. When a Security *Alert* dialog box appears, accept the certificate – it can be trusted. If a second certificate appears, accept it as well. Once you accept the certificate(s), the login page appears:

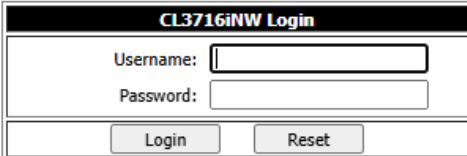

CL3716iNW Login	
Username:	<input type="text"/>
Password:	<input type="password"/>
<input type="button" value="Login"/>	<input type="button" value="Reset"/>



- Since this is the first time you are logging in, use the default Username: *administrator*, and the default Password: *password*.

Note: For security purposes, the system will prompt you to change the login password. The password must be different from your login password. (See *Changing the Super Administrator Login*, page 64 for details.)

- After you successfully log in, the browser GUI Main Page appears:

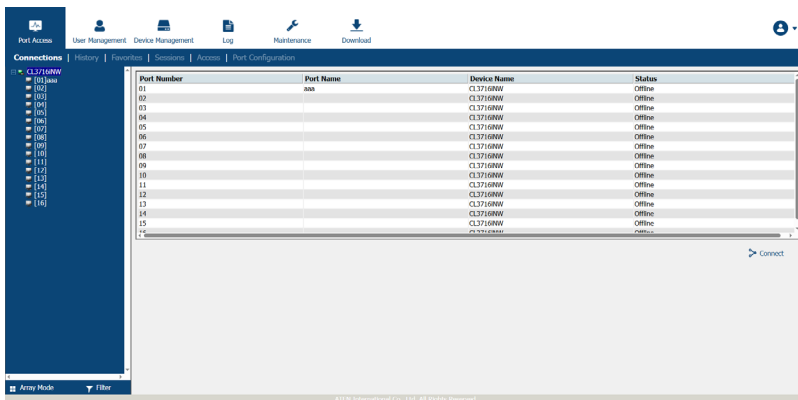

Network Setup

To set up the network, do the following:

1. Click the **Device Management** tab.
2. Select the **Network** tab.

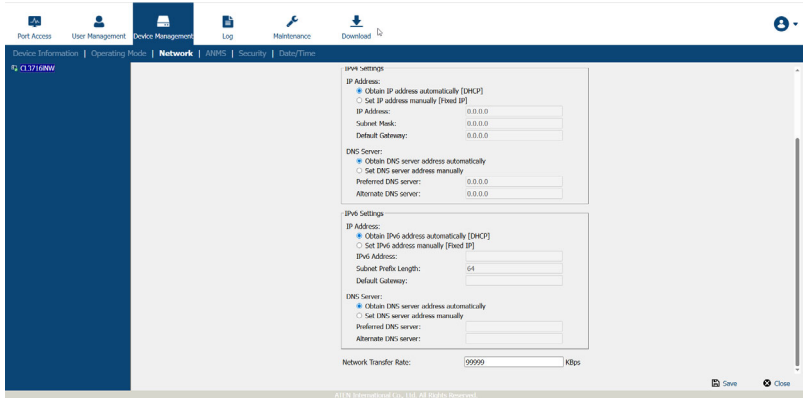

3. Fill in the fields according to the information provided under *Network*, page 159.

Changing the Super Administrator Login

To change the default Super Administrator Username and Password, do the following:

1. At the top of the screen, click the **User Management** tab.

The User Management page has a list of Users in the Sidebar at the left, and a more detailed list of users – with more information about them – in the large central panel. Since this is the first time the page is being accessed, only the Super Administrator appears:

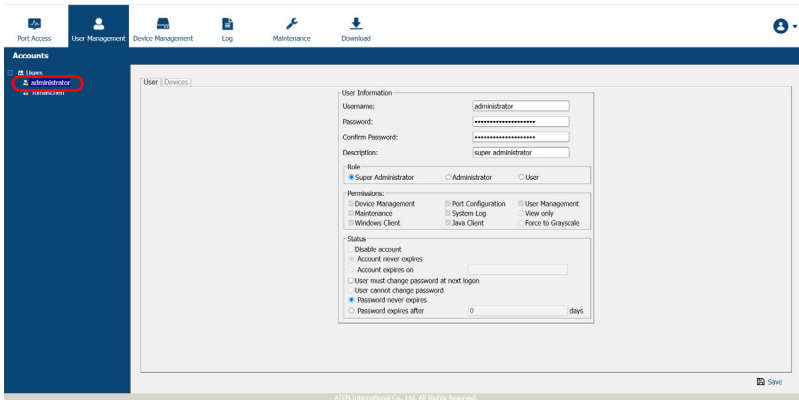

2. Click **administrator** in the left panel to change the default Super Administrator Username and Password. The *User Information* page appears:

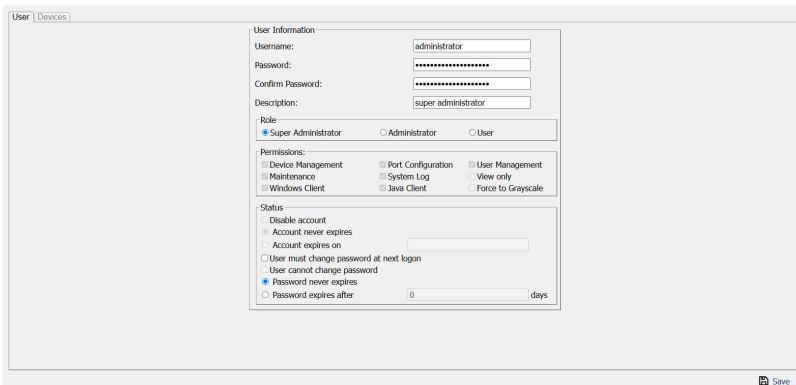

3. Change the Username and Password to something unique.

4. Enter the password again in the *Confirm Password* field to confirm it is correct.
5. Click **Save**.
6. When the dialog box informing you that the change completed successfully appears, Click **OK**.
7. Click on another item on the Local Console Main Page, to close this page.

Moving On

After setting up the network and changing the default Super Administrator password, you can proceed to other administration activities. These include User Management, Device Management, and Firmware Upgrade Maintenance.

These activities can be accomplished using any of the LCD KVM over IP switch's GUI utilities. These include the browser-based Windows GUI; the browser-based Java Client Viewer; the stand-alone Windows Client AP; and the stand-alone Java Client AP. Choose the approach that suits you best.

Note: Firmware Upgrade Maintenance cannot be performed from the local console. You must log in remotely with one of the LCD KVM over IP switch's other GUI utilities for this operation.

Chapter 7

Logging In

Overview (CL3708i / CL3716i Only)

LCD KVM over IP switches can be accessed from a local console; an Internet browser; a Windows application (AP) program; and a Java application (AP) program.

No matter which access method you choose, the LCD KVM over IP switch's authentication procedure requires you to submit a valid username and password. If you supply invalid login information, the authentication routine will return an *Invalid Username or Password*, or *Login Failed* message. If you see this type of message, log in again with a correct username and password.

Note: If the number of invalid login attempts exceeds a specified amount, a time out period is invoked. You must wait until the time out period expires before you can attempt to log in again. See *Login Failures*, page 170 for further details.

Browser Login

LCD KVM over IP switches can be accessed via an Internet browser running on any platform. To access the switch, do the following:

1. Open the browser and specify the IP address of the switch you want to access in the browser's location bar.

Note: For security purposes, a login string may have been set by the administrator (see page 175 for details). By default, there is no login string. If so, you must include a forward slash and the login string along with the IP address when you log in. For example:

192.168.0.100/k11116v

If you don't know the IP address and login string, ask your Administrator.

2. When a Security *Alert* dialog box appears, accept the certificate – it can be trusted. If a second certificate appears, accept it as well.

Once you accept the certificate(s), the login page appears:

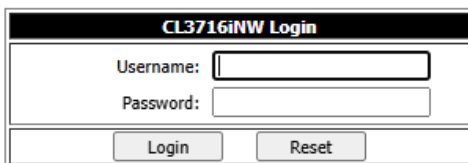

CL3716iNW Login	
Username:	<input type="text"/>
Password:	<input type="password"/>
<input type="button" value="Login"/>	<input type="button" value="Reset"/>



3. Provide your username and password (set by the administrator), then click **Login** to bring up the Web Main Page. For a discussion of the Web Main Page, see page 77.

Note: If you are the administrator and are logging in for the first time, use the default username (*administrator*) and the default password (*password*). For security purposes, the system will prompt you to change the login password. The password must be different from your login password.

Windows Client AP Login

In some cases, the Administrator may not want the LCD KVM over IP switch to be available via browser access. The Windows AP Client allows direct remote access to Windows systems users, without having to go through a browser (although you initially download the Windows AP Client program from the browser page – see Chapter 14, *Download*).

To connect to the LCD KVM over IP switch, go to the location on your hard disk that you downloaded the Windows AP Client program to, and double-click its icon (*WinClient.exe*) to bring up the Windows Client Connection Screen:

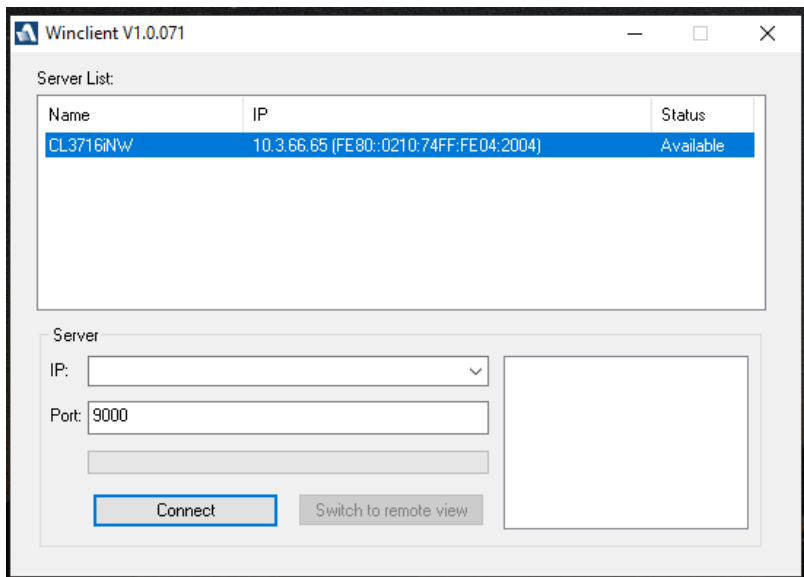

The Windows Client AP Connection Screen

A description of the Connection Screen is given in the following table:

Item	Description
Menu Bar	<p>The Menu Bar contains two items: File and Help.</p> <ul style="list-style-type: none"> ◆ The <i>File Menu</i> allows the operator to Create, Save, and Open user created Work files (see <i>The File Menu</i>, page 72). ◆ The <i>Help Menu</i> displays the WinClient AP version.
Server List	<p>Each time the WinClient.exe file is run, it searches the user's local LAN segment for LCD KVM over IP switches, and lists whichever ones it finds in this box. If you want to connect to one of these units, double-click it. (See <i>Connecting – Windows Client AP</i>, page 71 for details.)</p> <p>Note: 1. The switch will not appear in the list unless its <i>Enable Device List</i> configuration parameter has been enabled. See <i>Operating Mode</i>, page 157 for details.</p> <p>2. Only units whose Access Port settings for <i>Program</i> (see <i>Service Ports</i>, page 160) match the number specified for <i>Port</i> in the Server area of this dialog box appear in the Server List window.</p>
Server	<p>This area is used when you want to connect to a LCD KVM over IP switch at a remote location. You can drop down the IP list box and select an address from the list. If the address you want isn't listed, you can key in the target IP address in the IP field, and its port number in the Port field. (If you don't know the port number, contact your Administrator.)</p> <ul style="list-style-type: none"> ◆ When the IP address and Port number have been specified, click Connect. (See <i>Connecting – Windows Client AP</i>, page 71 for details.) ◆ When you have finished with your session and come back to this dialog box, click Disconnect to end the connection.
Message Panel	<p>Located just to the right of the Server panel, the Message panel lists status messages regarding the connection to the LCD KVM over IP switch.</p>
Switch to Remote View	<p>Once you have been authenticated (see <i>Connecting – Windows Client AP</i>, page 71 for details), this button becomes active. Click it to switch to the GUI Main Page. The GUI Main Page is described on <i>The AP GUI Main Page</i>, page 85.</p>

Connecting – Windows Client AP

To connect to a LCD KVM over IP switch do the following:

- From the *Server List* box, **double-click** the device that you wish to connect to.
– Or –
Specify its IP address and port number in the *Server IP* and *Port* input boxes.
- Click **Connect**.
The *Login* dialog box appears:

- Key in a valid Username and Password, and then click **OK**.
- Once you have been authenticated, you are automatically brought to the GUI main page. The *Switch to Remote View* button becomes active once you close the GUI main page. Click it to connect to the switch and bring up its GUI Main Page. For a description of the GUI Main Page, see page 48.

Name	IP	Status
CL3716INW	10.3.66.65 (FE80:0210:74FF:FE04:2004)	Available

Server

IP: 10.3.66.65

Port: 9000

Disconnect Switch to remote view

Server is ready.

The File Menu

The *File Menu* allows the operator to Create, Save, and Open user created Work files. A Work File consists of all the information specified in a Client session. This includes the Server List and Server IP list items, as well as the Hotkey settings.

Whenever a user runs the Client program, it opens with the values contained in the *current work file*. The current work file consists of the values that were in effect the last time the program was closed.

The File menu consists of the following items:

Item	Description
New	Allows the user to create a named work file so its values will not be lost, and it will be available for future recall.
Open	Allows the user to open a previously saved work file and use the values contained in it.
Save	Allows the user to save the values presently in effect as the <i>current work file</i> .
Exit	Exits the WinClient.

Java Client AP Login

In those cases in which the Administrator does not want the LCD KVM over IP switch to be available via browser access, but the local client users aren't running Windows, the Java AP Client provides direct remote access to non-Windows systems users (although you initially download the Java AP Client program from the browser page – see Chapter 14, *Download*).

To connect to the LCD KVM over IP switch, go to the location on your hard disk that you downloaded the Java AP Client program to, and double-click its icon (*JavaClient.jar*) to bring up the Java Client Connection Screen:

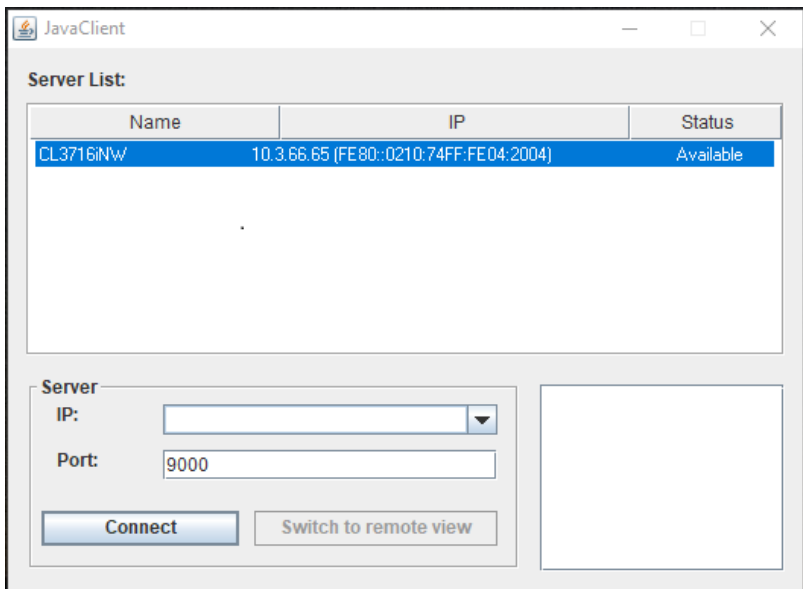

The Java Client AP Connection Screen

A description of the Connection Screen is given in the following table:

Item	Description
Server List	<p>Each time the JavaClient.jar file is run, it searches the User's local LAN segment for LCD KVM over IP switches, and lists whichever ones it finds in this box. If you want to connect to one of these units, double-click it. (See <i>Connecting – Windows Client AP</i>, page 71 for details.)</p> <p>Note:</p> <ol style="list-style-type: none"> 1. The switch will not appear in the list unless its <i>Enable Device List</i> configuration parameter has been enabled. See <i>Operating Mode</i>, page 157 for details. 2. Only units whose Access Port settings for <i>Program</i> (see <i>Service Ports</i>, page 160) match the number specified for <i>Port</i> in the Server area of this dialog box appear in the Server List window.
Server	<p>This area is used when you want to connect to a LCD KVM over IP switch at a remote location. You can drop down the IP list box and select an address from the list. If the address you want isn't listed, you can key in the target IP address in the IP field, and its port number in the Port field. (If you don't know the port number, contact your Administrator.)</p> <ul style="list-style-type: none"> ◆ When the IP address and Port number have been specified, click Connect. (See <i>Connecting – Windows Client AP</i>, page 71 for details.) ◆ When you have finished with your session and come back to this dialog box, click Disconnect to end the connection.
Message Panel	<p>Located just to the right of the Server panel, the Message panel lists status messages regarding the connection to the LCD KVM over IP switch.</p>
Switch to Remote View	<p>Once you have been authenticated (see <i>Connecting – Windows Client AP</i>, page 71 for details), this button becomes active. Click it to switch to the GUI Main Page. For more information on the GUI Main Page, see <i>The AP GUI Main Page</i>, page 85.</p>

Connecting – Java Client AP

To connect to a LCD KVM over IP switch do the following::

1. From the *Server List* box, **double-click** the device that you wish to connect to.
– Or –
Specify its IP address and port number in the *Server IP* and *Port* input boxes.
2. Click **Login**
The *Login* dialog box appears:

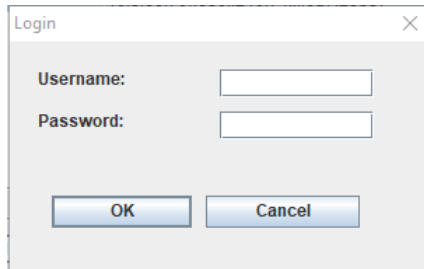

3. Key in a valid Username and Password, and then click **OK**.
4. Once you have been authenticated, you are automatically brought to the GUI main page. The *Remote View* button becomes active once you close the GUI main page. Click it to connect to the switch and bring up its GUI Main Page. For a description of the GUI Main Page, see page 48.

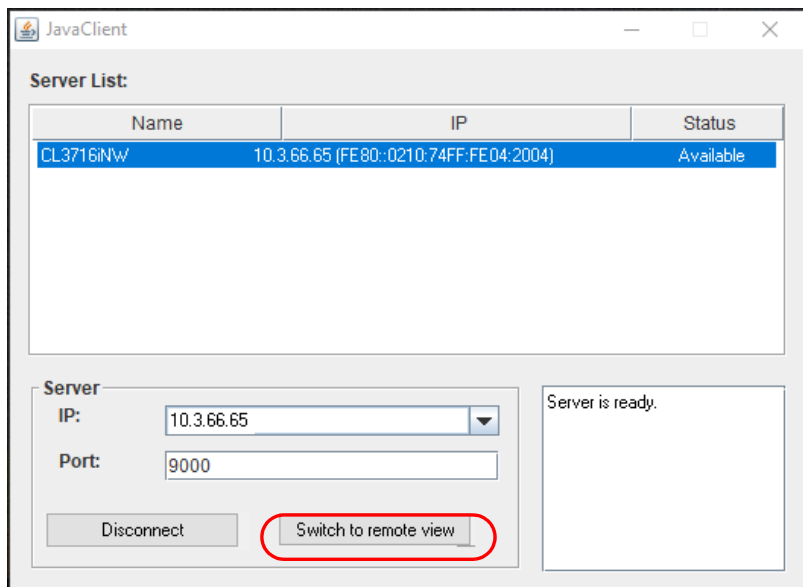

Name	IP	Status
CL3716iNw	10.3.66.65 (FE80::0210:74FF:FE04:2004)	Available

Server

IP: 10.3.66.65

Port: 9000

Disconnect Switch to remote view

Server is ready.

Chapter 8

The User Interface

Overview (CL3708i / CL3716i Only)

Once you have successfully logged in, the LCD KVM over IP switch's user interface Main Page appears. The look of the page varies slightly, depending on which method you used to log in. Each of the interfaces is described in the sections that follow.

The Web Browser Main Page

To ensure multi-platform interoperability, access to the LCD KVM over IP switches can be accomplished with most standard web browsers. Once users log in and are authenticated (see page 68), the *Web Browser Main Page* comes up, with the Port Access page displayed:

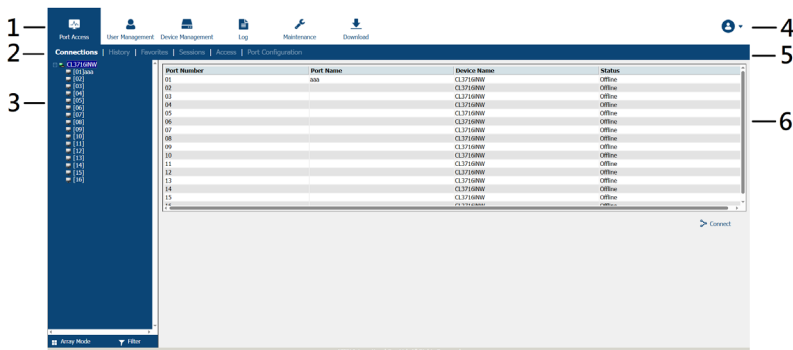

Note: The screen depicts a Super Administrator's page. Depending on a user's type and permissions, not all of these elements appear.

Page Components

The web page screen components are described in the table, below:

No.	Item	Description
1	Tab Bar	The tab bar contains the LCD KVM over IP switch's main operation categories. The items that appear in the tab bar are determined by the user's type, and the authorization options that were selected when the user's account was created.
2	Menu Bar	The menu bar contains operational sub-categories that pertain to the item selected in the tab bar. The items that appear in the menu bar are determined by the user's type, and the authorization options that were selected when the user's account was created.
3	Sidebar	The Sidebar provides a tree view listing of ports that relate to the various tab bar and menu bar selections. Clicking a node in the Sidebar brings up a page with the details that are relevant to it. There is a <i>Filter</i> button at the bottom of the Sidebar that lets you expand or narrow the scope of the ports that appear in the tree. For more information on <i>Filter</i> , see <i>Filter</i> , page 116.
4	User Settings	Click this button for user information, configure user preferences settings, change password, logout, and online help. See <i>User Settings</i> , page 79.
5	Welcome Message	If this function is enabled (see <i>Welcome Message</i> , page 78), a welcome message displays here.
6	Interactive Display Panel	This is your main work area. The screens that appear reflect your menu choices and Sidebar node selection.

User Settings

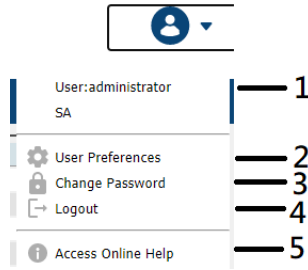

No.	Item	Description
1	User Information	Display the user information and its description.
2	User Preferences	Click to configure the user preferences settings. See <i>User Preferences</i> , page 79.
3	Change Password	Click to change the login password. See <i>Change Password</i> , page 82.
4	Logout	Click to log out and end your LCD KVM over IP switch session.
5	Access Online Help	Click to open the user manual automatically.

User Preferences

The *User Preferences* page allows users to set up their own, individual, working environments. The switch stores a separate configuration record for each user profile, and sets up the working configuration according to the *Username* that was keyed into the Login dialog box:

The screenshot shows a 'User Preferences' dialog box with the following settings:

- Language: English
- OSD Hotkey: [Ctrl] [Ctrl]
- ID Display: Port Number + Port Name
- ID Duration: 3 sec
- Scan Duration: 5 sec
- Screen Blanker: 0 min
- Logout Timeout: 0 min
- Toolbar: Enable Disable
- Viewer:
 - #1 Web Client (selected)
 - #2 Win Client
 - #3 Java Client

Buttons: Save, Cancel

The page settings are explained in the following table:

Setting	Function
Language	Selects the language that the interface displays in.
OSD Hotkey	Selects which Hotkey controls the GUI function: [Scroll Lock] [Scroll Lock] is the default. To select a different combination, click the arrow at the right of the box to drop down the list of choices.
ID Display	Selects how the Port ID is displayed: the Port Number alone (PORT NUMBER); the Port Name alone (PORT NAME); or the Port Number plus the Port Name (PORT NUMBER + PORT NAME). The default is PORT NUMBER + PORT NAME.
ID Duration	Determines how long a Port ID displays on the monitor after a port change has taken place. You can choose an amount from 1—255 seconds. The default is 3 Seconds. A setting of 0 (zero) means the Port ID is always on.
Scan Duration	Determines how long the focus dwells on each port as it cycles through the selected ports in Auto Scan Mode. Key in a value from 1—255 seconds. The default is 5 seconds; a setting of 0 disables the Scan function.

Setting	Function						
Screen Blanker	<p>If there is no input from the console for the amount of time set with this function, the screen is blanked. Key in a value from 1—30 minutes. A setting of 0 disables this function. The default is 0 (disabled).</p> <p>Note: Although this function can be set from either the local console or a remote login, it only affects the local console monitor.</p>						
Logout Timeout	<p>If there is no user input for the amount of time set with this function, the user is automatically logged out. A login is necessary before the LCD KVM over IP switch can be accessed again.</p>						
Toolbar	<p>Selects whether or not the Port Toolbar is enabled when a port is accessed.</p> <p>Since the Toolbar functions are also available from the GUI Control Panel (see <i>The Control Panel</i>, page 87), you may prefer to disable it here.</p>						
Viewer*	<p>In the browser version of this page, a <i>Viewer</i> section is available. You can choose which viewer method is preferred when connecting to a port.</p> <div data-bbox="358 884 964 984" style="border: 1px solid black; padding: 5px;"> <p>Viewer:</p> <table border="1" style="width: 100%; border-collapse: collapse;"> <tr> <td style="padding: 2px;">#1 Web Client</td> <td style="text-align: right; padding: 2px;">↑</td> </tr> <tr style="background-color: #e0f0ff;"> <td style="padding: 2px;">#2 Java Client</td> <td style="text-align: right; padding: 2px;"></td> </tr> <tr> <td style="padding: 2px;">#3 Win Client</td> <td style="text-align: right; padding: 2px;">↓</td> </tr> </table> </div> <p>Refer to <i>Viewer Preference</i> on page 82 (below) for more information.</p>	#1 Web Client	↑	#2 Java Client		#3 Win Client	↓
#1 Web Client	↑						
#2 Java Client							
#3 Win Client	↓						
Save	<p>Click Save to save any changes made to the User Preferences settings.</p>						

Note: 1. *This item is only available with the Browser version.

2. The *local console's User Preferences* page additionally (and exclusively) provides the **Beeper** setting for users to turn the device's beeper on (default) or off.

Change Password

- ◆ In the Browser GUI, to change a user's password, key in the old password and new password into their input boxes; key the new password into the *Confirm* input box, then click **Change Password** to apply the change.
- ◆ In the AP GUI version, click **Change Password**; key in the old password and new password into their input boxes; key the new password into the *Confirm* input box, then click **Save**.

Viewer Preference

This section only appears in the browser version of the *User Preferences* page and is mainly concerned with the automatic viewer selection of the system.

To choose a viewer manually, refer to *Connecting to a Port*, page 204.

Usable viewers are automatically determined by the status of the system at the time of the login and by the type of browser.





When you try to connect to a port (double-click the port or select a port and click the **Connect**), the system will use the viewer according to the viewer list. An example is shown below:



- ◆ The top-most method is the most preferred method and is listed as #1 (Win Client by default).
- ◆ If the preferred method is supported when connecting to a port, the system will try connecting using the preferred method.
- ◆ If the method is not supported, the system will try connecting using the next method, and try the last method last.





Adjust Viewer Preference



Follow the steps below to adjust the preference.

1. Click to select and highlight the method. The *#2 Java Client* method is shown above as the selected.
2. Click the up  or down  arrow to shift its position around. The up arrow  brings it up (more preferred) while the down arrow  brings it down (less preferred).

The Tab Bar

The number and type of icons that appear on the Tab Bar at the top of the page are determined by the user's type (Super Administrator, Administrator, User) and the permissions assigned when the user's account was created. The functions associated with each of the icons are explained in the table below:

Icon	Function
	Port Access: The Port Access page is used to access and control the devices on the LCD KVM over IP switch installation. This page is available to all users.
	User Management: The User Management page is used to create and manage Users and Groups. It can also be used to assign devices to them. For details on the User Management page, see Chapter 10, <i>User Management</i> . This tab is available to the Super Administrator, as well as administrators and users who have been given User Management permission. The tab doesn't appear for other administrators and users.
	Device Management: The Device Management page is used to configure and control the overall operation of the LCD KVM over IP switch. This page is available to the Super Administrator, as well as administrators and users who have been given Device Management permission. The tab doesn't appear for other administrators and users.
	Log: The Log page displays the contents of the log file. The Log page is discussed on Chapter 12, <i>Log</i> .

Icon	Function
	<p>Maintenance: The Maintenance page is used to install new firmware; backup and restore configuration and account information; ping network devices; and restore default values. The Maintenance page is discussed on Chapter 13, Maintenance. This page is available to the Super Administrator (and Administrators and Users with <i>Maintenance</i> permission). The icon doesn't display on the page of ordinary administrators and users.</p>
	<p>Download: Users can click this icon to download AP versions of the Windows Client; the Java Client; and the Log Server. This page is available to all users. The programs that can be downloaded depend on the user's permissions.</p>

The AP GUI Main Page

With WinClient AP, and Java Client AP access, once users log in, the *GUI Main Page* comes up:

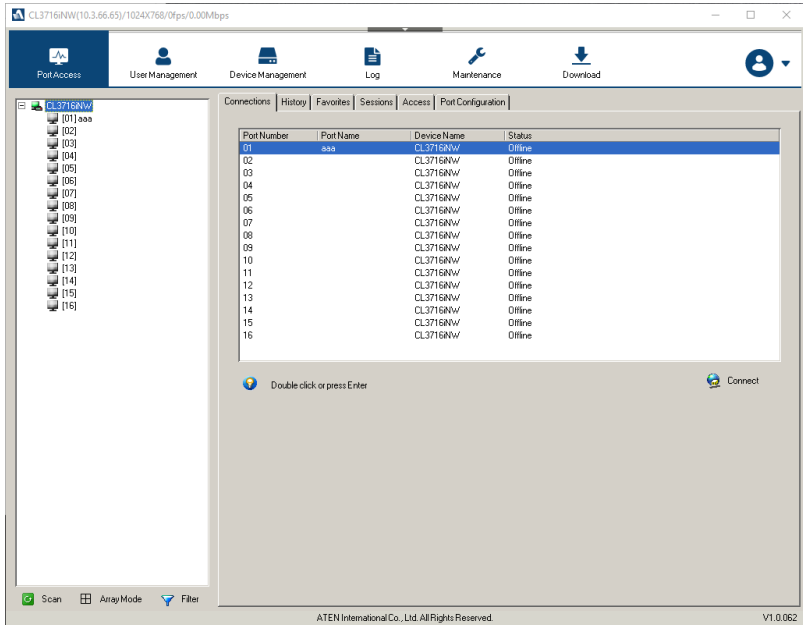

The GUI Main Page is similar to that of the Web Browser. The differences between them are as follows:

1. The AP GUI version doesn't have a menu bar below the tab bar; it has a series of tabs like a notebook, instead. Like the Web Browser interface, however, the makeup of the tabbed notebook changes depending on the items selected on the main Tab Bar and in the Sidebar.
2. In addition to *Filter*, there are also buttons for *Scan* and *Array Mode* at the bottom of the Sidebar. These functions are discussed in Chapter 9, *Port Access*.
3. There is a hidden *Control Panel* at the upper or lower center of the screen that becomes visible when you mouse over it. (The default is at the upper center of the screen.)

4. The GUI can be navigated via the keyboard as shown in the table, below:

Keys	Action
Ctrl + P	Opens the Port Access page.
Ctrl + U	Opens the User Management page.
Ctrl + D	Opens the Device Management page.
Ctrl + L	Opens the Log page.
Ctrl + M	Opens the Maintenance page.
Ctrl + A	Opens the Download page.
F1	To see <i>About</i> information
F2	To edit the port name of the selected port.
F4	Selects the Sidebar (left) panel.
F5	Selects the main (right) panel
F7	Closes the GUI.
F8	To log out.

The Control Panel

WinClient Control Panel

Since the WinClient Control Panel (for the ActiveX Web Viewer and WinClient AP) contains the most complete functionality, this section describes the WinClient Control Panel. Although the Java Control Panel (for the Web Viewer and Java Client AP) does not enable all of the features that this one does, the functions that they do share are the same, and you can refer to the information described here when using it.

The Control Panel is hidden at the upper or lower center of the screen (the default is at the upper center), and becomes visible when you mouse over it. The panel consists of two rows: an icon row at the top, and one text rows below it:



Note: The above image shows the complete Control Panel. The icons that appear can be user selected. See *Customize Control Panel Configuration*, page 105, for details.

- ◆ By default, the left of the text row shows the video resolution of the remote display. As the mouse pointer moves over the icons in the icon bar, however, the information in the text row changes to describe the icon's function. In addition, if a message from another user is entered in the message board, and you have not opened the message board in your session, the message will appear in the text row.
- ◆ The right of the text row shows the IP address of the device you are accessing. The center of the row indicates which bus the user is on (the number before the slash), and the total number of users on that bus (the number behind the slash).

Note: 1. The bus and user information in the center of the row only displays if it has been enabled.

2. See *Multiuser Operation*, page 214 for further information regarding the LCD KVM over IP switch's bus assignments.
-



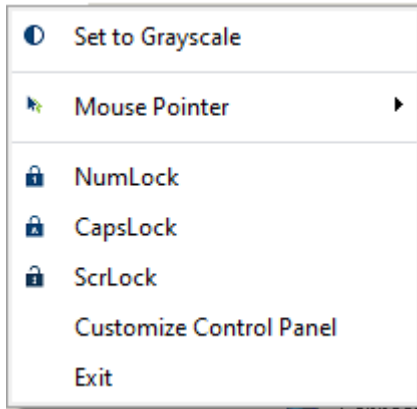





- ◆ Right clicking in the text row area brings up a menu-style version of the toolbar. In addition, it allows you to select options for the *Screen Mode*, *Zoom*, *Mouse Pointer*, and *Macro List*. These functions are discussed in the sections that follow.











- ◆ To move the Control Panel to a different location on the screen, place the mouse pointer over the text row area, then click and drag.

WinClient Control Panel Functions

The Control Panel functions are described in the table below.

Icon	Function
	This is a toggle. Click to make the Control Panel persistent – i.e., it always displays on top of other screen elements. Click again to have it display normally.
	Under an accessed port, click to recall the GUI.
	Click to bring up the Video Options dialog box. Right-click to perform a quick Auto Sync (see <i>Video Settings</i> , page 91, for details).
	Toggles the display between <i>Full Screen Mode</i> and <i>Windowed Mode</i> .
	Click to zoom the remote display window. Note: This feature is only available in windowed mode (Full Screen Mode is off). See <i>Zoom</i> , page 94 for details.
	Click to toggle the remote display between color and gray scale views.
	Under an accessed port, click to invoke Panel Array Mode (see <i>Panel Array Mode</i> , page 211).
	Click to toggle Automatic or Manual mouse sync. ♦ When the selection is <i>Automatic</i> , a green ✓ appears on the icon. ♦ When the selection is <i>Manual</i> , a red X appears on the icon. See <i>Mouse DynaSync Mode</i> , page 95 for a complete explanation of this feature.
	Click to select the mouse pointer type. Note: This icon changes depending on which mouse pointer type is selected (see <i>Mouse Pointer Type</i> , page 104).

	<p>Click to bring up the on-screen keyboard (see <i>The On-Screen Keyboard</i>, page 97).</p>
	<p>Click to take a snapshot (screen capture) of the remote display. See <i>Snapshot</i>, page 106, for details on configuring the Snapshot parameters.</p>
	<p>Click to send a Ctrl+Alt+Del signal to the remote system.</p>
	<p>Click to bring up the Message Board (see <i>The Message Board</i>, page 100).</p>
	<p>These icons show the Num Lock, Caps Lock, and Scroll Lock status of the remote computer.</p> <ul style="list-style-type: none"> ◆ When the lock state is <i>On</i>, the LED is bright green and the lock hasp is closed.
	<ul style="list-style-type: none"> ◆ When the lock state is <i>Off</i>, the LED is dull green and the lock hasp is open. <p>Click on the icon to toggle the status.</p>
	<p>Note: These icons and your local keyboard icons are in sync. Clicking an icon causes the corresponding LED on your keyboard to change accordingly. Likewise, pressing a Lock key on your keyboard causes the icon's color to change accordingly.</p>
	<p>Click to bring up more control panel functions. See <i>More Control Panel Functions</i>, page 103.</p>



Video Settings

Clicking the *Video Settings* icon on the Control Panel brings up the *Basic Video Settings* dialog box with basic settings. The options in the basic dialog box allow you to set Auto-Sync, and slide the Performance bar setting. Selecting the *Advanced* button opens the *Advanced Video Settings* dialog box, providing more detailed options including; Video Quality, Enable Refresh, Transparency and Color Depth Control, as shown below and on the next page:

Basic Video Settings

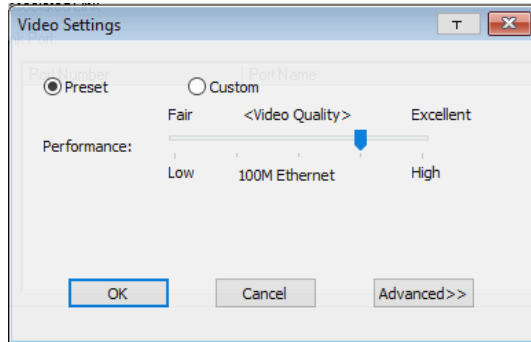

Advanced Video Settings

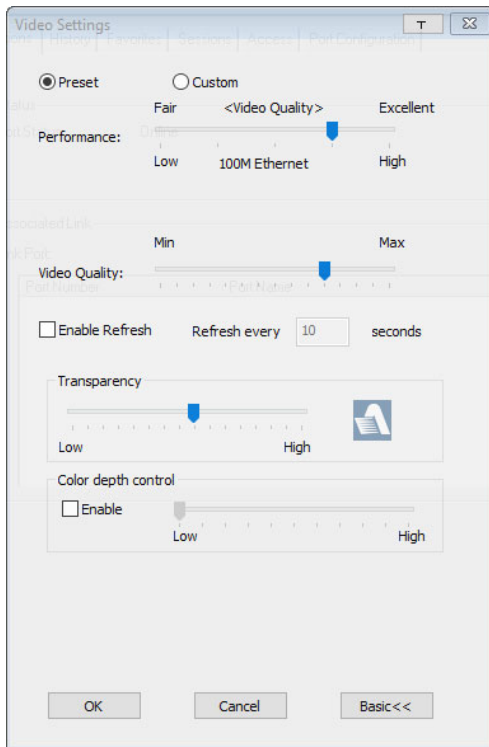

The meanings of the video adjustment options are given in the table:

Options	Usage
Preset / Custom	Using the Preset and Custom buttons allow you to set and save custom video settings, and revert back to default video settings.
Performance	Use the slide bar to select the type of Internet connection that the local client computer uses. The switch will use that selection to automatically adjust the <i>Video Quality</i> settings to optimize the quality of the video display. Since network conditions vary, if none of the pre-set choices seem to work well, you can select <i>Advanced</i> and use the Video Quality slider bar to adjust the settings to suit your conditions.

Options	Usage
Video Quality	Drag the slider bar to adjust the overall Video Quality. The larger the value, the clearer the picture and the more video data goes through the network. Depending on the network bandwidth, a high value may adversely effect response time.
Enable Refresh	<p>The LCD KVM over IP switch can redraw the screen every 1 to 99 seconds, eliminating unwanted artifacts from the screen. Select Enable Refresh and enter a number from 1 through 99. The LCD KVM over IP switch will redraw the screen at the interval you specify. This feature is disabled by default. Click to put a check mark in the box next to <i>Enable Refresh</i> to enable this feature.</p> <p>Note:</p> <ol style="list-style-type: none"> 1. The switch starts counting the time interval when mouse movement stops. 2. Enabling this feature increases the volume of video data transmitted over the network. The lower the number specified, the more often the video data is transmitted. Setting too low a value may adversely affect overall operating responsiveness.
Transparency	Adjusts the transparency of the toolbar that comes up when the GUI hotkey ([Scroll Lock][Scroll Lock], for example), is invoked. Slide the bar until the display in the example window is to your liking.
Color Depth Control	This setting determines the richness of the video display by adjusting the amount of color information.

Network Bandwidth Information for KVM Sessions





For network bandwidth management, under ideal circumstances, a KVM session of a full-screen video display at 1920x1080 @60Hz will take up approximately 64Mbps.

However, since the network environment of each station/session varies, the aforementioned information proposes what is ideal but does not warrant the smoothness/quality for each session.



Zoom

The Zoom icon controls the zoom factor for the remote view window. Settings are as follows:

Setting	Description
100%	Sizes and displays the remote view window at 100%.
75%	Sizes and displays the remote view window at 75%.
50%	Sizes and displays the remote view window at 50%.
25%	Sizes and displays the remote view window at 25%.
	Sizes and displays the remote view window at 100%. The difference between this setting and the 100% setting is that when the remote view window is resized its contents don't resize – they remain at the size they were. To see any objects that are outside of the viewing area move the mouse to the window edge, to have the screen scroll.
	
	
	





Mouse DynaSync Mode

Synchronization of the local and remote mouse pointers is accomplished either automatically or manually.

Automatic Mouse Synchronization (DynaSync)

Mouse DynaSync provides automatic locked-in synching of the remote and local mouse pointers – eliminating the need to constantly resync the two movements.

The icon on the Control Panel indicates the synchronization mode status as follows:

Icon	Function
	This icon displays in gray to indicate that Mouse DynaSync is not available – you must use manual synching procedures.
	The green check mark on this icon indicates that Mouse DynaSync is available and is enabled . This is the default setting when Mouse DynaSync is available. (See the Note, above.)
	The red X on this icon indicates that Mouse DynaSync is available but is not enabled .

When *Mouse DynaSync* is available, clicking the icon toggles its status between enabled and /disabled. If you choose to disable Mouse DynaSync mode, you must use the manual synching procedures described under *Manual Mouse Synchronization*, page 96.

Mac and Linux Considerations

- ◆ For Mac OS versions 10.4.11 or later, there is a second DynaSync setting to choose from. If the default Mouse DynaSync result is not satisfactory, try the **Mac 2** setting. To select Mac 2, right click in the text area of the Control Panel and select *Mouse Sync Mode* → *Automatic for Mac 2*:

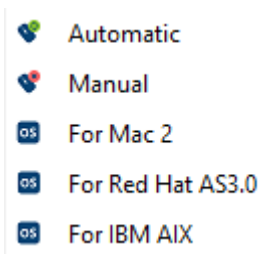

- ◆ Linux doesn't support DynaSync Mode, but there is a setting on the Mouse Sync Mode menu for Redhat AS3.0 systems. If you are using a USB Adapter Cable (see the Note on the previous page), with an AS3.0 system and the default mouse synchronization is not satisfactory, you can try the Redhat AS3.0 setting. In either case, you must perform the manual mouse synchronization procedures described in the next section.

Manual Mouse Synchronization

If the local mouse pointer goes out of sync with the remote system's mouse pointer there are a number of methods to bring them back into sync:

1. Perform a video and mouse auto sync by clicking the *Video Settings* icon on the Control Panel (see page 91).
2. Perform an *Auto Sync* with the Video Adjustment function (see *Video Settings*, page 91, for details).
3. Invoke the *Adjust Mouse* function with the *Adjust Mouse* hotkeys (see *Mouse Pointer Type*, page 104, for details).
4. Move the pointer into all 4 corners of the screen (in any order).
5. Drag the Control Panel to a different position on the screen.

Set the mouse speed and acceleration for each problematic server attached to the switch.



The On-Screen Keyboard

The LCD KVM over IP switch supports an on-screen keyboard, available in multiple languages, with all the standard keys for each supported language. Click this icon to pop up the on-screen keyboard:

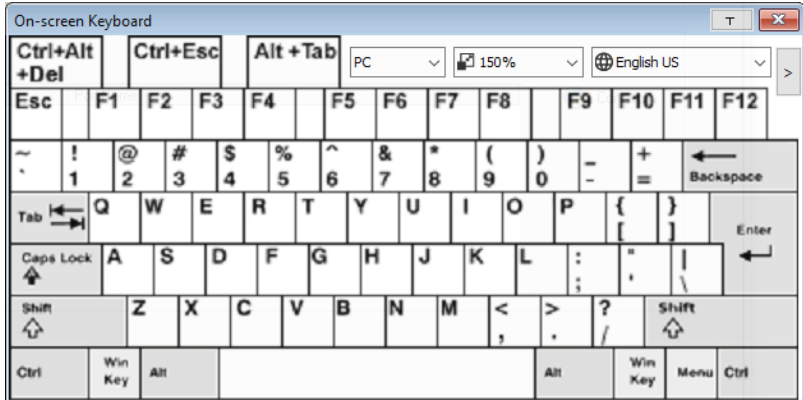

One of the major advantages of the on-screen keyboard is that if the keyboard languages of the remote and local systems aren't the same, you don't have to change the configuration settings for either system. Just bring up the on-screen keyboard; select the language used by the server you are accessing; and use the on-screen keyboard to communicate with it.

Note: You must use your mouse to click on the keys. You cannot use your actual keyboard.

Changing Languages

To change languages, do the following:

1. Click the down arrow next to the currently selected language, to drop down the language list.

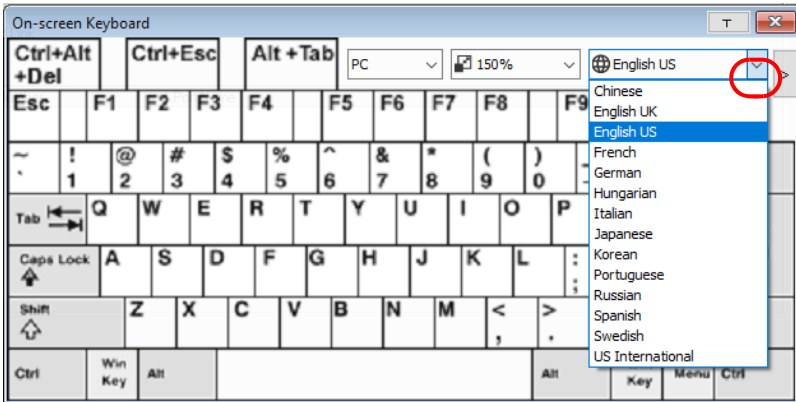

2. Select the new language from the list.

Resizing the Keyboard

To resize the keyboard, do the following:

1. Click the down arrow next to the currently selected keyboard size, to drop down the sizing list.

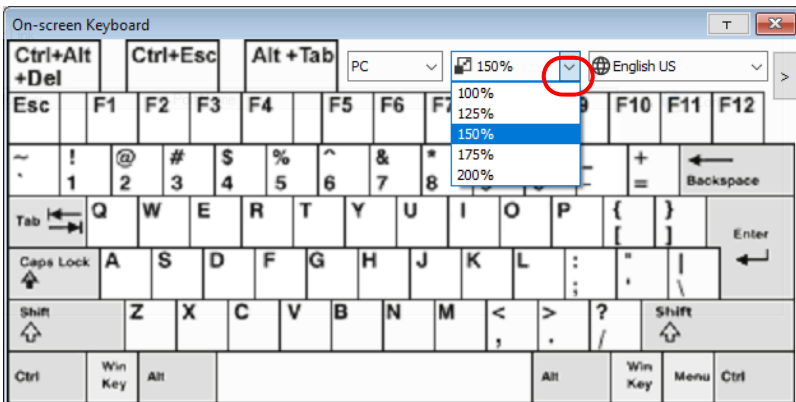

2. Select the new keyboard size from the list.

Selecting Platforms

The On-screen Keyboard supports the Sun platform as well as the PC. To select the platform, do the following:

1. Click the down arrow next to the currently selected platform, to drop down the platform list.

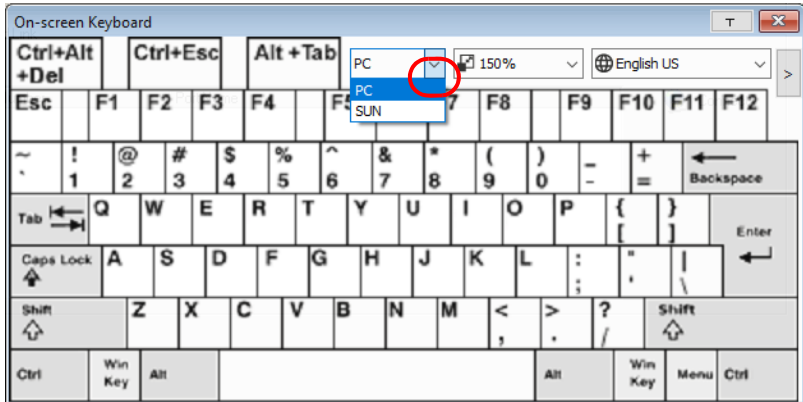

2. Select the new platform from the list.

Expanded Keyboard

To display/hide the expanded keyboard keys, click the arrow to the right of the language list arrow.

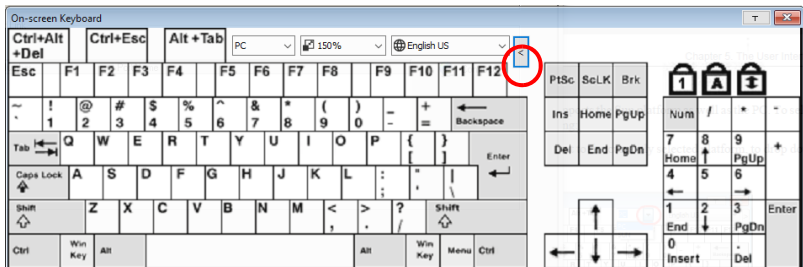





The Message Board

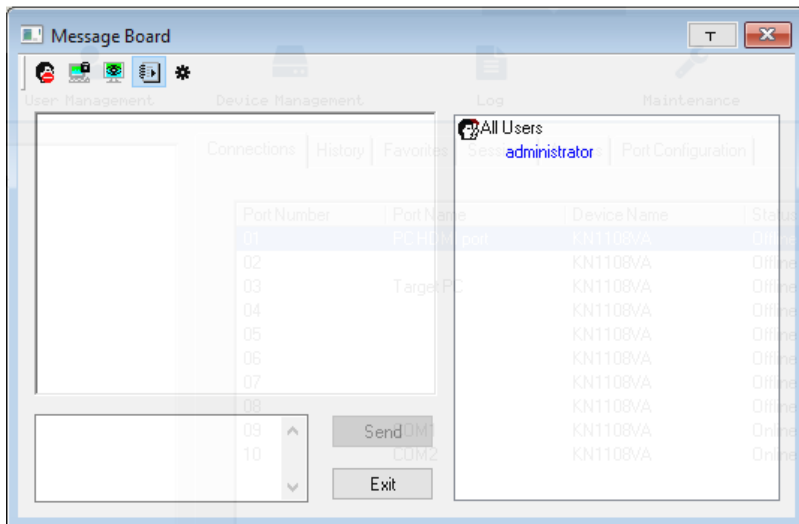

The LCD KVM over IP switch supports multiple user logins, which may cause access conflicts. To alleviate the problem, a message board has been provided, which allows users to communicate with each other:



Button Bar

The buttons on the Button Bar are toggles. Their actions are described in the table below:

Button	Action
	Enable/Disable Chat. When disabled, messages posted to the board are not displayed. The button is shadowed when Chat is disabled. The icon displays next to the user's name in the User List panel when the user has disabled Chat.
	Occupy/Release Keyboard/Video/Mouse. When you Occupy the KVM, other users cannot see the video, and cannot input keyboard or mouse data. The button is shadowed when the KVM is occupied. The icon displays next to the user's name in the User List panel when the user has occupied the KVM.
	Occupy/Release Keyboard/Mouse. When you Occupy the KM, other users can see the video, but cannot input keyboard or mouse data. The button is shadowed when the KM is occupied. The icon displays next to the user's name in the User List panel when the user has occupied the KM.

	Show/Hide User List. When you Hide the User List, the User List panel closes. The button is shadowed when the User List is open.
	Message Board Pop Up Settings. Click to enable the pop up message board when messages received setting.

Message Display Panel

Messages that users post to the board - as well as system messages - display in this panel. If you disable Chat, however, messages that get posted to the board won't appear.

Compose Panel

Key in the messages that you want to post to the board in this panel. Click **Send**, or press **[Enter]** to post the message to the board.

User List Panel

The names of all the logged in users are listed in this panel.

- ◆ Your name appears in blue; other users' names appear in black.
- ◆ By default, messages are posted to all users. To post a message to one individual user, select the user's name before sending your message.
- ◆ If a user's name is selected, and you want to post a message to all users, select All Users before sending your message.
- ◆ If a user has disabled Chat, its icon displays before the user's name to indicate so.
- ◆ If a user has occupied the KVM or the KM, its icon displays before the user's name to indicate so.

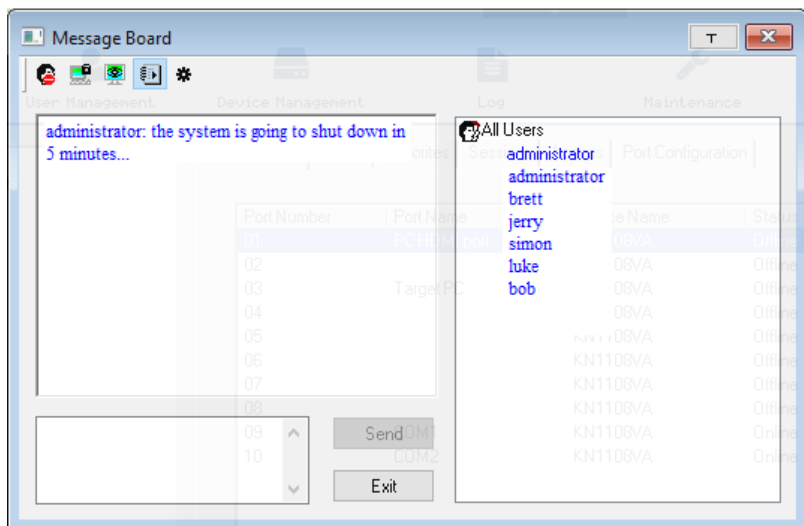

More Control Panel Functions

More Control Panel functions are described in the table below.

Icon	Function
Customize Control Panel	Click to bring up the Control Panel Configuration dialog box. See <i>Customize Control Panel Configuration</i> , page 105, for details on configuring the Control Panel.
Exit	Click to exit the WinClient.



Mouse Pointer Type

LCD KVM over IP switches offer a number of mouse pointer options when working in the remote display. Click this icon to select from the available choices:

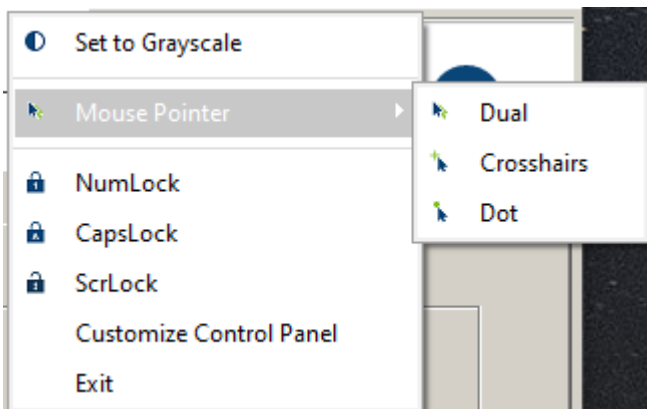

-
- Note:**
1. Before accessing a port, only Dual and Crosshairs are available for the Windows Viewers. Once the port is accessed, three pointers are available.
 2. The Dot pointer is not available with the Java Client Viewer or the Java Client AP.
 3. Selecting the Single pointer has the same effect as the *Toggle mouse display* hotkey function.
 4. The icon on the Control Panel changes to match your choice.
-

Customize Control Panel Configuration

Clicking the *Customize Control Panel* icon brings up a dialog box that allows you to configure the items that appear on the Control Panel, as well as its graphical settings:

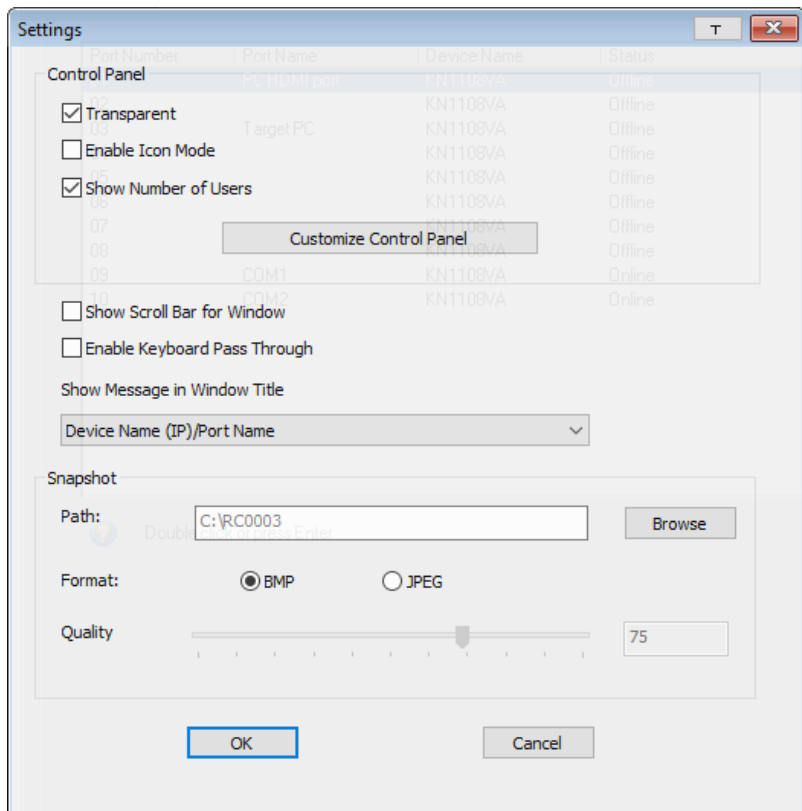

The organization of the dialog box is described in the table, below:

Item	Description
Control Panel	<ul style="list-style-type: none"> ◆ Enabling <i>Transparent</i> makes the Control Panel semi-transparent, so that you can see through it to the display underneath. ◆ Enabling <i>Enable Icon Mode</i> causes the Control Panel to display as an icon until you mouse over it. When you mouse over the icon, the full panel comes up. ◆ Enabling <i>Show Number of Users</i> shows the number of the bus you are on, as well as the total number of users on the bus, displays on the bottom row center of the Control Panel as follows: Bus No./ Total Users. (See the Control Panel diagram on page 87 for an example.)
Customize Control Panel	<p>Allows you to select which icons display in the Control Panel. Check the ones you want to see, uncheck the ones you don't want.</p>
Show Scroll Bar for Window	<p>In cases where the remote screen display is larger than your monitor, you can choose how to scroll to the areas that are off-screen.</p> <p>When this is enabled, the show bar for windows allows scroll bars to appear around the screen borders that you can use to scroll to the off-screen areas.</p>
Enable Keyboard Pass Through	<p>When this is enabled, the Alt-Tab key press is passed to the remote server and affects that server. If it is not enabled, Alt-Tab acts on your local client computer.</p>
Show Message in Window Title	<p>Select to show message such as port name, device name, resolution, frame rate, and bandwidth in the window title.</p>
Snapshot	<p>These settings let the user configure the LCD KVM over IP switch's screen capture parameters (see the <i>Snapshot</i> description under <i>The Control Panel</i>, page 87):</p> <ul style="list-style-type: none"> ◆ Path lets you select a directory that the captured screens automatically get saved to. Click Browse; navigate to the directory of your choice; then click OK. If you don't specify a directory here, the snapshot is saved to your desktop. ◆ Click a radio button to choose whether you want the captured screen to be saved as a BMP or a JPEG (JPG) file. ◆ If you choose JPEG, you can select the quality of the captured file with the slider bar. The higher the quality, the better looking the image, but the larger the file size.

The Java Control Panel



The Java Client Viewer and Java Client AP Control Panel is similar to the one used by the WinClient:





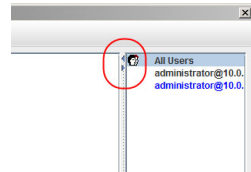











The major differences between them are:

- ◆ In the Macros dialog box, *Toggle Mouse Display* is not available.
- ◆ The *Dot* mouse pointer type is not available.
- ◆ In the Message Board, there is no *Show/Hide* button to show or hide the user list. This function is achieved by clicking the arrows at the top of the bar that separates the User List panel from the main panel.
- ◆ The Control Panel *Lock LED* icons are not in sync with your keyboard. When you first connect, the LED display may not be accurate. To be sure, click on the LED icons to set them.
- ◆ In *Control Panel Configuration*, the BMP Snapshot format has been replaced by PNG.
- ◆ To access to the Customize Control Panel, right click in the text row area brings up a menu-style version of the toolbar. In addition, it allows you to select options for the *Screen Mode*, *Zoom*, *Mouse Pointer*, and *Macro List*. These functions are discussed in the sections that follow.



Icon	Function
	This is a toggle. Click to make the Control Panel persistent – i.e., it always displays on top of other screen elements. Click again to have it display normally.
	Under an accessed port, click to recall the GUI.
	Click to bring up the Video Options dialog box. Right-click to perform a quick Auto Sync (see <i>Video Settings</i> , page 91, for details).

	<p>Toggles the display between <i>Full Screen Mode</i> and <i>Windowed Mode</i>.</p>
	<p>Click to zoom the remote display window. Note: This feature is only available in windowed mode (Full Screen Mode is off). See <i>Zoom</i>, page 94 for details.</p>
	<p>Click to toggle the remote display between color and gray scale views.</p>
	<p>Under an accessed port, click to invoke Panel Array Mode.</p>
	<p>Click to toggle Automatic or Manual mouse sync.</p> <ul style="list-style-type: none"> ◆ When the selection is <i>Automatic</i>, a green √ appears on the icon. ◆ When the selection is <i>Manual</i>, a red X appears on the icon. <p>See <i>Mouse DynaSync Mode</i>, page 95 for a complete explanation of this feature.</p>
	<p>Click to select the mouse pointer type. Note: This icon changes depending on which mouse pointer type is selected (see <i>Mouse Pointer Type</i>, page 104).</p>
	<p>Click to bring up the on-screen keyboard (see <i>The On-Screen Keyboard</i>, page 97).</p>
	<p>Click to take a snapshot (screen capture) of the remote display. See <i>Snapshot</i>, page 106, for details on configuring the Snapshot parameters.</p>
	<p>Click to send a Ctrl+Alt+Del signal to the remote system.</p>
	<p>Click to bring up the Message Board (see <i>The Message Board</i>, page 100).</p>







	<p>These icons show the Num Lock, Caps Lock, and Scroll Lock status of the remote computer.</p> <ul style="list-style-type: none">◆ When the lock state is <i>On</i>, the LED is lights orange and the lock hasp is closed.
	<ul style="list-style-type: none">◆ When the lock state is <i>Off</i>, the LED is lights blue and the lock hasp is open. <p>Click on the icon to toggle the status.</p>
	<p>Note: These icons and your local keyboard icons are in sync. Clicking an icon causes the corresponding LED on your keyboard to change accordingly. Likewise, pressing a Lock key on your keyboard causes the icon's color to change accordingly.</p>
	<p>Click to bring up more control panel functions. See <i>Customize Control Panel Configuration</i>, page 105.</p>



WebClient Control Panel

The WebClient Viewer is similar to the one used by the WinClient but with fewer functions:











These functions are discussed in the sections that follow.

Icon	Function
	This is a toggle. Click to make the Control Panel persistent – i.e., it always displays on top of other screen elements. Click again to have it display normally.
	Click to bring up the Video Options dialog box. Right-click to perform a quick Auto Sync (see <i>Video Settings</i> , page 91, for details).
	Toggles the display between <i>Full Screen Mode</i> and <i>Windowed Mode</i> .
	Click to toggle the remote display between color and gray scale views.
	Under an accessed port, click to invoke Panel Array Mode.
	Click to toggle Automatic or Manual mouse sync. <ul style="list-style-type: none"> ◆ When the selection is <i>Automatic</i>, a green √ appears on the icon. ◆ When the selection is <i>Manual</i>, a red X appears on the icon. See <i>Mouse DynaSync Mode</i> , page 95 for a complete explanation of this feature.
	Click to select the mouse pointer type. Note: This icon changes depending on which mouse pointer type is selected (see <i>Mouse Pointer Type</i> , page 104).

	Click to bring up the on-screen keyboard (see <i>The On-Screen Keyboard</i> , page 97).
	Click to select the port you wish to connect to.
	Click to send a Ctrl+Alt+Del signal to the remote system.

The major differences between the WinClient and WebClient are:

- ◆ The Recall  is not available.
- ◆ The Zoom  is not available.
- ◆ The *Dot* mouse pointer type is not available.
- ◆ The Snapshot  is not available.
- ◆ The Message Board  is not available.
- ◆ The Num Lock  , Caps Lock  , and Scroll Lock  are not available.
- ◆ The More Control Panel  is not available.

Chapter 9

Port Access

Overview (CL3708i / CL3716i Only)

When you log in to the switch the *Port Access* page comes up with the LCD KVM over IP switch's KVM *Connections* page displayed.

Browser GUI

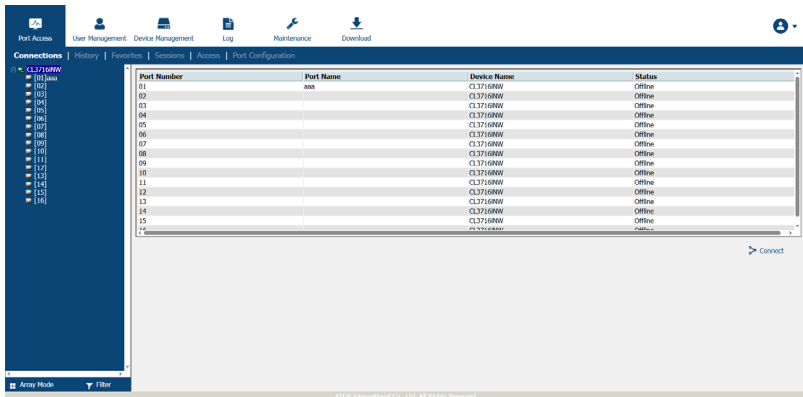

AP GUI

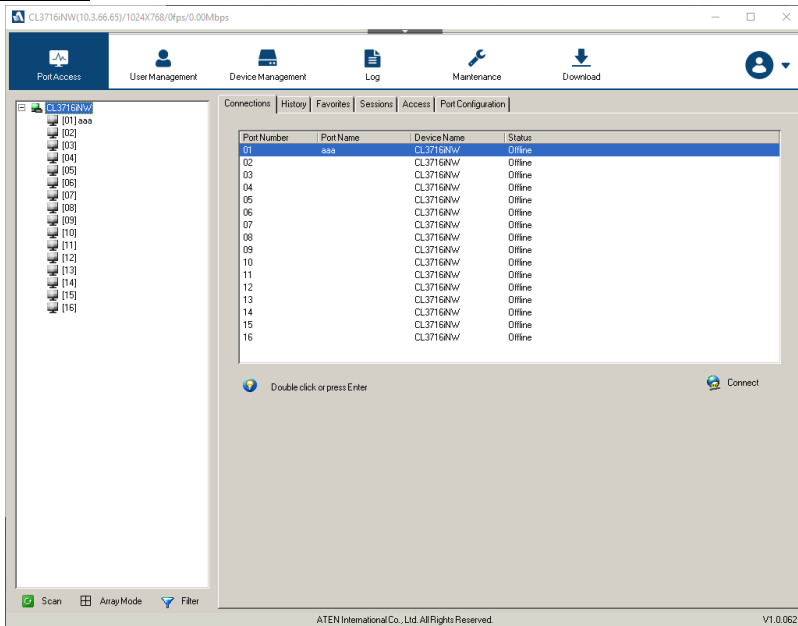

The Connections page is organized into several main areas. All the devices, ports, and outlets that a user is permitted to access are listed in the Sidebar at the left of the page.

After selecting a device, port, or outlet in the Sidebar, clicking entries on the menu bar (Browser GUI) or tab bar (AP GUI) opens information and configuration pages related to the item selected in the Sidebar.

The Sidebar

All KVM switches – including their ports and outlets – are listed in a tree structure in the Sidebar at the left of the screen:

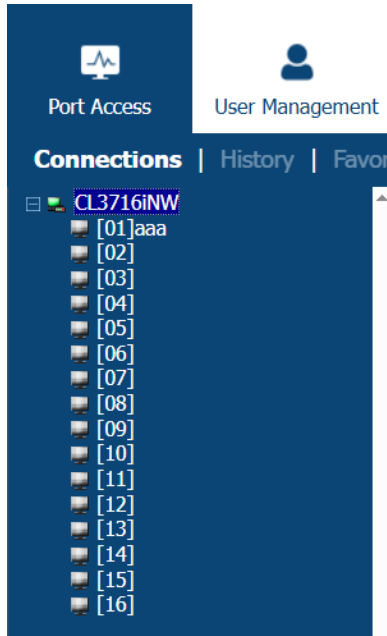

The Sidebar Tree Structure

The characteristics of the Sidebar tree structure are the following:

- ◆ Users are only allowed to see the devices and ports that they have access permission for.
- ◆ Ports station devices can be nested under their first station devices.
Click the + in front of a device to expand the tree and see the ports / outlets nested underneath it. Click the - to collapse the tree and hide the nested ports/outlets.
- ◆ A port's number is displayed in brackets next to its icon. The ports can also be named (see *Port Naming*, page 119, for details).
- ◆ Switches and ports that are on line have their monitor screen icons in Green; the monitor screens are Gray for devices and ports that are offline.
- ◆ Outlets that are *On* have their icons in Amber; the icons are Gray for outlets that are *Off*.

- ◆ To access and operate a port, double click its icon. Port operation details are discussed in Chapter 15, *Port Operation*.



Scan

Scan is found at the bottom of the AP GUI Sidebar. It automatically switches among all the ports that are visible in the Sidebar (see *Filter*, below), at regular intervals, so that their activity can be monitored automatically. See *Auto Scanning*, page 208 for details.

Note: This item doesn't appear at the bottom of the Sidebar in the Browser version. In that version, you must invoke it from the port's *Toolbar*. See *The Port Toolbar*, page 206 for details



Array

Array is found at the bottom of the AP GUI Sidebar. It represents another way of monitoring port activity. Under this function your screen is divided into a grid of panels, with each panel showing the video display of a particular port. Only ports that are visible in the Sidebar (see *Filter*, below), and that are on line are displayed – all other ports are blank. See *Panel Array Mode*, page 211 for details

Note: This item doesn't appear at the bottom of the Sidebar in the Browser version. In that version, you must invoke it from the port's *Toolbar*. See *The Port Toolbar*, page 206 for details



Filter

Filter allows you to control the number and type of ports that display in the Sidebar, as well as which ports get scanned when *Auto Scan* and *Array Modes* are invoked (see *Scan* and *Array*, above). When you click *Filter*, the bottom of the panel changes to look similar to the image, below:

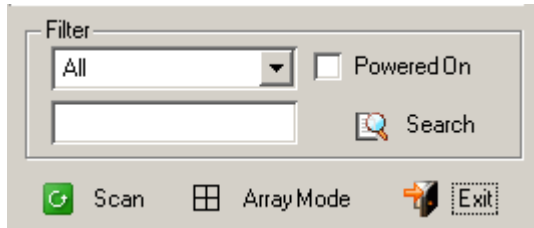

The meanings of the choices are explained in the following table:

Choices	Explanation
All	<p>This is the default view. With no other filter options selected, all of the ports that are accessible to the user are listed in the Sidebar.</p> <p>If any <i>Favorites</i> have been specified (see page 125), you can drop down the list box and select Favorites instead of All. If you select Favorites, only the items you have selected as Favorites display in the tree.</p>
Powered On	<p>If you enable <i>Powered On</i> (by putting a check in the checkbox) only the ports that have their attached devices powered on display in the tree.</p>
Search	<p>If you key in a search string and click Search, only port names that match the search string display in the tree. Wildcards (? for single characters; * for multiple characters) and the keyword or are supported, so that more than one port can show up in the list.</p> <p>For example:</p> <ol style="list-style-type: none"> 1. If you key in Web*, both Web Server 1 and Web Server 2 show up in the list. 2. If you key in W*1 or M*2, both Web Server 1 and Mail Server 2 show up in the list.
Exit	<p>Clicking Exit closes the filter dialog.</p>

Sidebar Utilities

The AP GUI version Port Access *Connections* page provides a convenient method to work with the Sidebar tree. When you right click an item, a list with various options pops up:

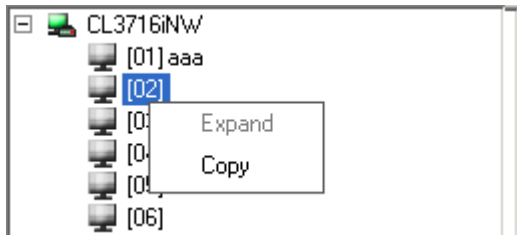

Note: The screenshot shows an example of just one of the pop-ups that can appear. The items that appear in the pop-up depend on whether you are logged in remotely or from a Local Console; what your user type is; and whether you selected a switch or a port.

The following table lists and explains all of the possible items that may appear:

Item	User Type	Explanation
Expand/ Collapse	Administrators Users	<ul style="list-style-type: none"> ◆ If the device's ports are nested (not displayed), the dialog box entry is <i>Expand</i>. Click Expand to display the nested ports. ◆ If the device's ports are displayed, the dialog box entry is <i>Collapse</i>. Click Collapse to nest the ports. <p>Note: 1. This item only appears for switches, or for ports that have cascaded station devices connected to them. 2. This has the same effect as clicking the + or - in the tree structure.</p>
Copy	Administrators Users	This item is only available for ports. After selecting Copy, you can Paste the port into the Favorites page. See <i>Adding a Favorite</i> , page 125 for details

Port Naming

For convenience – especially in large installations with many devices, ports and outlets – administrators and users with port configuration permission, can give each port or outlet a name. To assign, modify or delete a name, do the following:

1. Click once on the item you want to edit; wait a second; then click again.

Note: 1. This is not a double click. It involves two separate clicks. A double click will switch you to the device attached to the port.

2. In the AP GUI version you can right click on the port you want to edit, then select **Rename** in the popup box that appears, or you can highlight the port and press **F2**.
-

After a second or two, the field changes to provide a text input box:

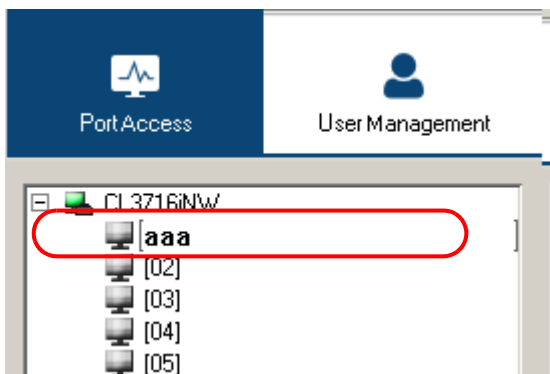

2. Key in a name for the item (or change/delete a previous one).
 - ◆ You can use any combination of letters, numbers, and symbols on the typewriter keys of keyboards with PC US English layout. In this case, the maximum number of characters allowed is 20.
 - ◆ You can also activate your local IME to input non-English characters. For languages that use 2 byte encoding, the maximum number of characters allowed is 9.

- When you have finished editing the name, press **[Enter]** or click anywhere outside of the input box to complete the operation.

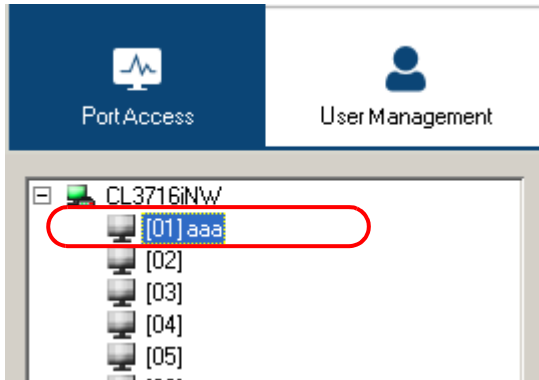

KVM Devices and Ports – Connections Page

For LCD KVM over IP switches, the *Connections* page displays port status information at the device level, and port connection configuration options at the port level.

Device Level

When a LCD KVM over IP switch is selected in the Sidebar, the Connections page displays a list of ports for the device that the user is authorized to access or view.

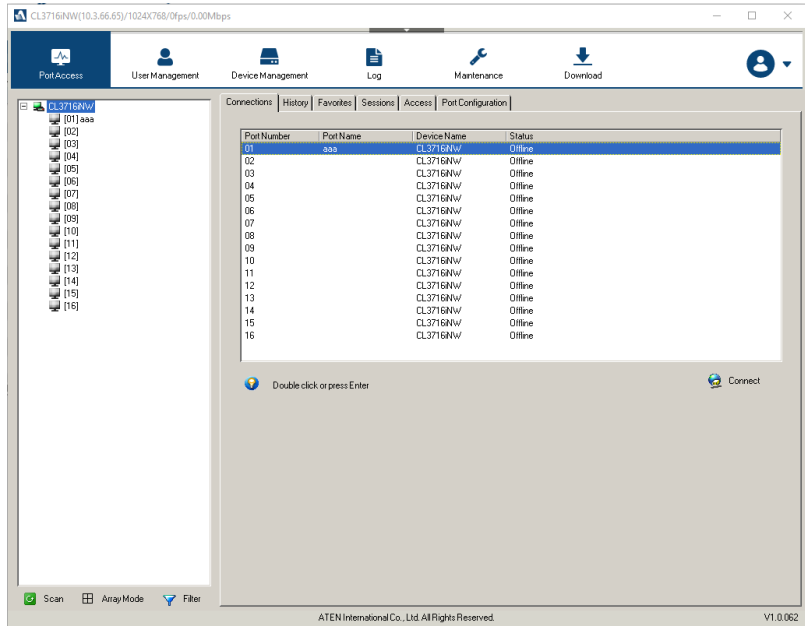

The following attributes are listed for each device:

- ◆ Port Number – the port's number on the switch.
- ◆ Port Name – if a name has been assigned to a port it displays here.
- ◆ Device Name – if a name has been assigned to the switch it displays here.
- ◆ Status – the current status of the port – online, or offline.

Note: The sort order of the information displayed can be changed by clicking the column headings.

You can access a port from the main panel either by double clicking anywhere on its line entry, or selecting it anywhere on its line entry and clicking **Connect** at the bottom right of the page.

Port Level

When a port is selected in the Sidebar, the *Connections* page changes to display the port connection and configuration options:

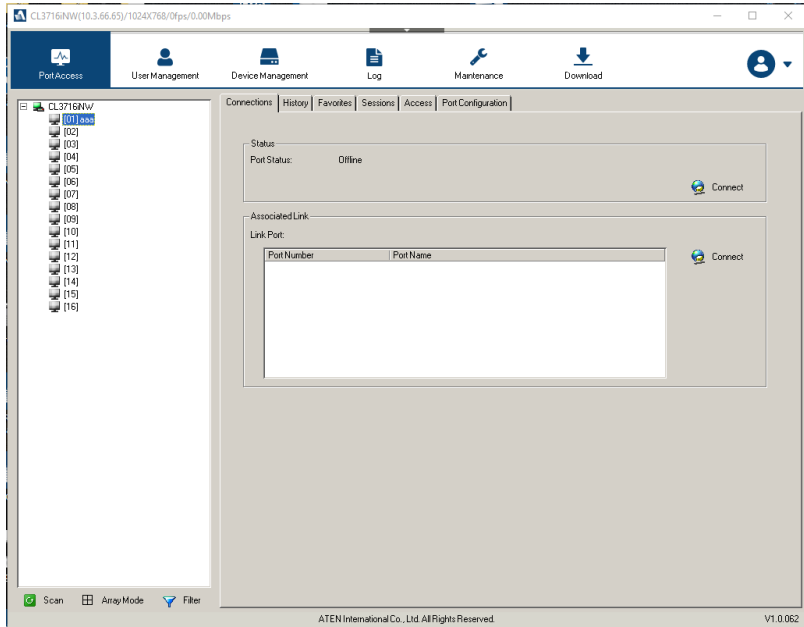

The screen is divided into three major panels, as described in the sections that follow.

Status

The Status Panel displays the port's current status information, including whether the port is online or offline, and if the port is mountable.

Click the **Connect** button to view the port display via the switch's built-in Win Viewer (when using Windows Internet Explorer), or Java Viewer (when using other web browsers).

Associated Links

The Associated Links panel displays ports that have been associated with the currently selected port. Associations are configured on the *Port Access* → *Port Configuration* → *Associated Links* page (see page 139 for details).

History

The History page provides a record of each time that a port was accessed. It provides quick access to the most recently used ports. You can access a port shown in the main panel by double clicking it.

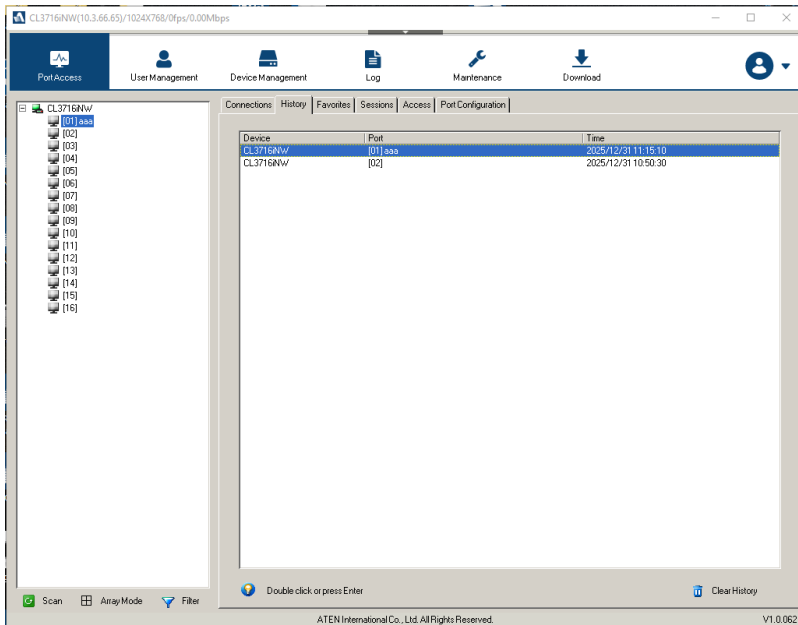

- ◆ If there are more entries than there is room on the screen, a scroll bar appears to let you scroll up and down to see the entire record.
- ◆ To clear the record and start over, click the *Clear History* button at the bottom right of the page.

Note: You can change the sort order of the information displayed by clicking the column headings.

Favorites

The *Favorites* page is similar to a bookmarks feature. Ports that you frequently access can be saved in a list here. Simply open this page and select the port – rather than hunting for it in the Sidebar. This feature is especially handy on large, crowded installations:

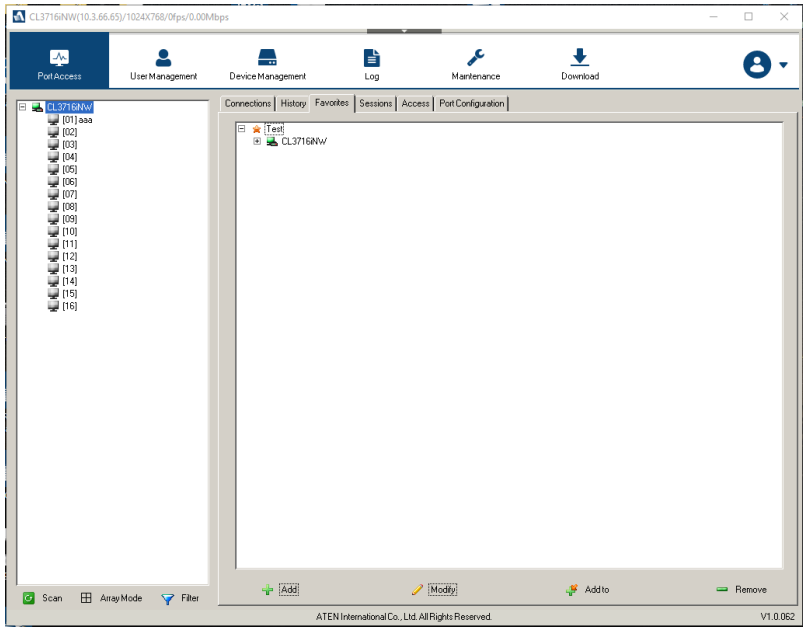

Adding a Favorite

To add a port to the favorites, do the following:

1. Right click in the main panel; click **Add Favorite**.

– or –

Click **Add** at the bottom left of the main panel.

An *Untitled Favorite* entry appears:

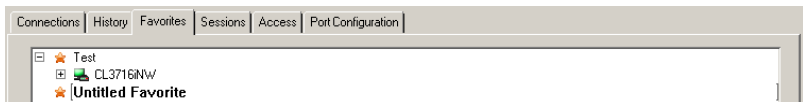

- This will be a container to hold your port entries. Click inside the text entry box to erase *Untitled Favorite* and key in an appropriate name, then click on any empty space in the main panel.

- To add a port:
Drag it from the Sidebar and drop it onto the container

– or –

Right Click on it in the Sidebar; select **Copy**. Right click on the container; select **Paste**.

– or –

Select the container in the main panel; select the port in the Sidebar; then click **Add to** at the bottom of the main panel.

The switch that the port belongs to is added to the container; the selected port is appended under the switch.

Note: To add multiple ports at the same time, hold the Shift or Ctrl key down while you make your Sidebar selections then drag or copy the entire group to the Favorites panel.

- Repeat step 3 for any other *Favorite* categories you wish to create

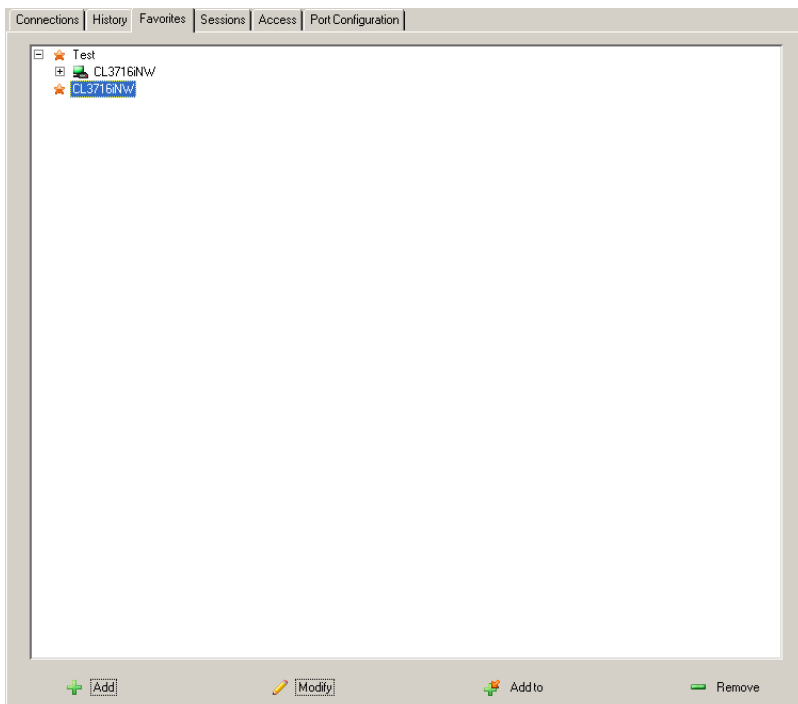

Note: Favorites can be selected for filtering in the Sidebar. See *Filter*, page 116 for details

Modifying a Favorite

- ◆ To modify a Favorite, or one of the items contained in it, right click on it, then select a choice from the popup menu that appears.
- ◆ To edit a Favorite's name:

Click on it once, wait a second, then click again. You can edit the name after the display changes to provide a text input box, This is the same procedure as the one described for port naming (see *Port Naming*, page 119).

– or –

Select the Favorite in the main panel, then click **Modify** at the bottom of the main panel.

Sessions

The *Session* page lets the administrator and users with User Management permissions see at a glance which users are currently logged into the LCD KVM over IP Switch, and provides information about each of their sessions.

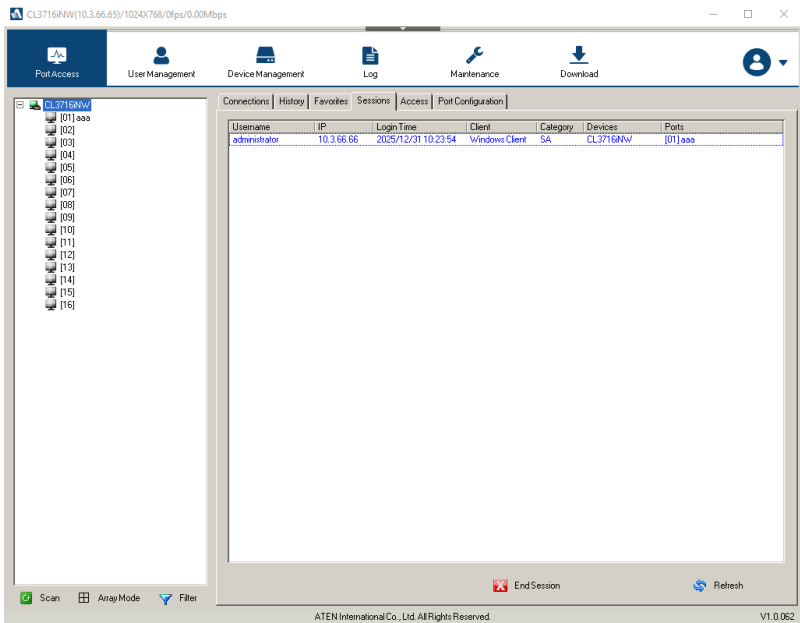

- Note:**
1. The Session page isn't available for ordinary users.
 2. Users with User Management permissions can only see the sessions of ordinary users
 3. The *Category* heading lists the type of user who has logged in: SA (Super Administrator); Admin (Administrator); Normal user (User).

The meanings of the headings at the top of the page are fairly straightforward. The *IP* heading refers to the IP address that the user has logged in from; the *Device* and *Port* headings show which device and port the user is currently accessing.

Note: The sort order of the information displayed can be changed by clicking the column headings.

This page also gives the administrator the option of forcing a user logout by selecting the user and clicking **End Session** at the bottom of the main panel.

Access

Administrators use the *Access* page to set user and group access and configuration rights for switches and ports.

Note: The *Access* page only appears for those users with User Management permissions. It isn't available for other users.

Device Level Browser GUI Interface

If a switch is chosen in the Sidebar, the Main panel looks similar to the one shown below:

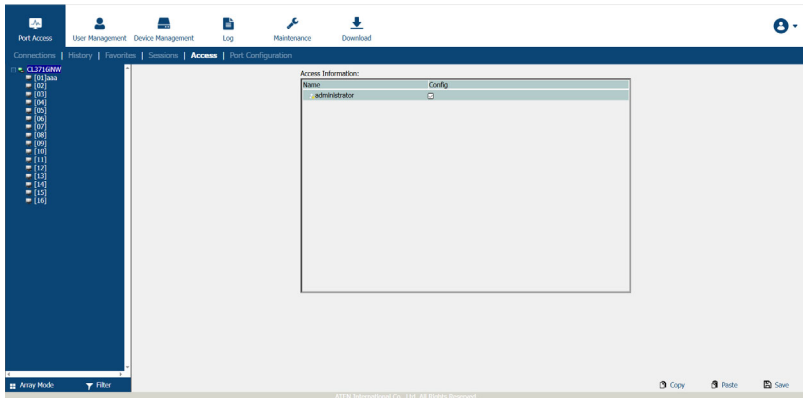

The main panel consists of two columns: *Name*, and *Config*:

- ◆ *Name* lists all the users and groups that have been created.
- ◆ *Config* indicates the users who have Configuration privileges. A check mark () indicates that the user has permission to make changes to the switch configuration settings (see Chapter 11, *Device Management*); an X means that the user is denied permission to make configuration changes. Click the icon to toggle permission for Administrators and Users (Super Administrators always have configuration privileges).
- ◆ The *Copy* and *Paste* buttons at the bottom of the main panel provide a shortcut method of assigning the permissions settings of one port to any of the other ports. To do so:
 1. Select the port whose permissions you want the other port(s) to follow.
 2. Click **Copy**.
 3. Select the port you want to receive the permissions.

4. Click **Paste**.



- ◆ When you have finished making your configuration changes, click **Save**.

Port Level Browser GUI Interface

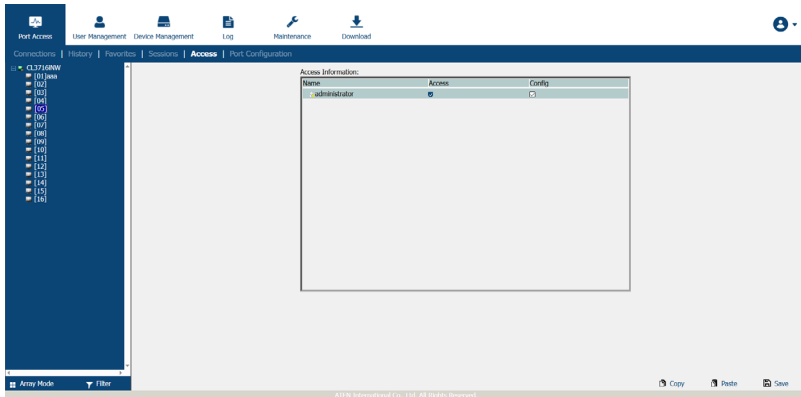
If a port is chosen in the Sidebar, the Main panel looks similar to the one shown below:



The port access settings are explained in the following table:

Setting	Description	
Name	Each port accessible to the user is listed under the <i>Names</i> column.	
Access	The Access column is where device access rights are set. To cycle through the choices, click the icon in the row that corresponds to the user you want to configure. The meanings of the icons are as follows	
		Full Access The user can view the remote screen and can perform operations on the remote server from his keyboard and monitor.
		View Only The user can only view the remote screen; he cannot perform any operations on it.
	No Access No access rights - the Port will not show up on the User's list on the Main Screen.	
Config	Sets or denies permission for the user to make changes to a port's configuration settings. A check mark (✓) indicates that the user has permission; an X means that the user does not have permission.	

Device Level AP GUI Interface

If a switch is chosen in the Sidebar, the Main panel looks similar to the one below:

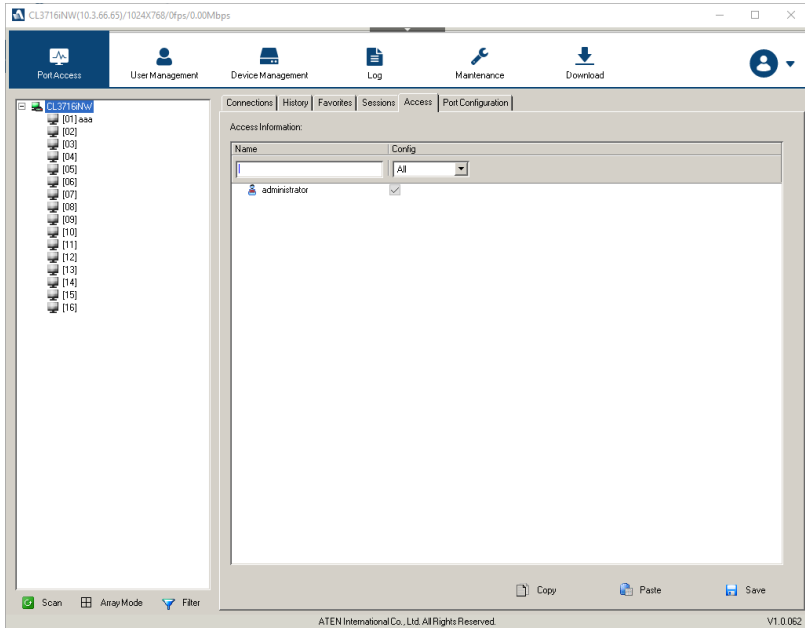

The page is essentially the same as the one for the Browser GUI (see page 129), with the exception that there are filters at the top of the columns. The filters allow you to expand or limit the scope of the users and groups that are displayed, as described in the following table:

Filter	Description
Name	<p>To filter on the User or Group name, key in the name, partial name or partial name, then press Enter. Only the Users and Groups whose names correspond to what you have keyed in appear in the list.</p> <p>Wildcards (? for single characters; * for multiple characters) and the keyword "or" are supported. E.g., h*ds would return hands and hoods; h?nd would return hand and hind, but not hard; h*ds or h*ks would return hands and hooks.</p>

Filter		Description
Config	All	All Users and Groups appear in the list.
	Permitted	Only Users and Groups with configuration permissions appear in the list.
	Restricted	Only Users and Groups that do not have configuration permissions appear in the list.

Port Level AP GUI Interface

If a port is chosen in the Sidebar, the Main panel looks similar to the one below:

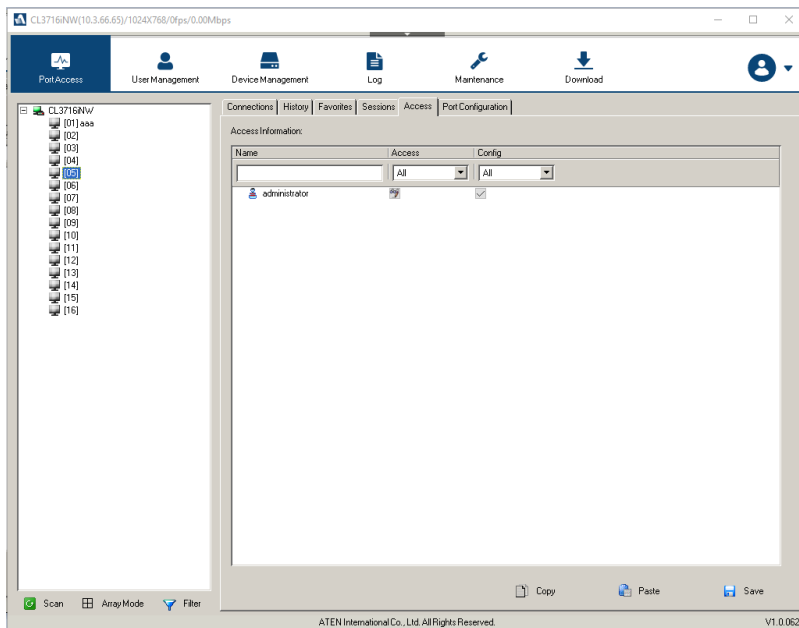

The page is essentially the same as the one for the Browser GUI (see page 130), with the exception that there are filters at the top of the columns. The filters allow you to expand or limit the scope of the users and groups that are displayed, as described in the following table:

Filter	Description
Name	To filter on the User or Group name, key in the name, partial name, or partial name and wild card (*) then press Enter . Only the Users and Groups whose names correspond to what you have keyed in appear in the list.

Filter		Description
Access	All	All Users and Groups appear in the list.
	Full Access	Only Users and Groups with Full Access permissions appear in the list.
	View Only	Only Users and Groups with View Only permissions appear in the list.
	No Access	Only Users and Groups with No Access permissions appear in the list.
Config	All	All Users and Groups appear in the list.
	Permitted	Only Users and Groups with Permitted Config permissions appear in the list.
	Restricted	Only Users and Groups with Restricted Config permissions appear in the list.

Saving Changes

Click the **Save** button at the lower right corner of the page to save any changes made on the Access page.

Port Configuration

Device Level

When a device is selected in the Sidebar, the only item available under Port Configuration is the Port Properties page with one field to configure: the *Occupy Timeout* setting:

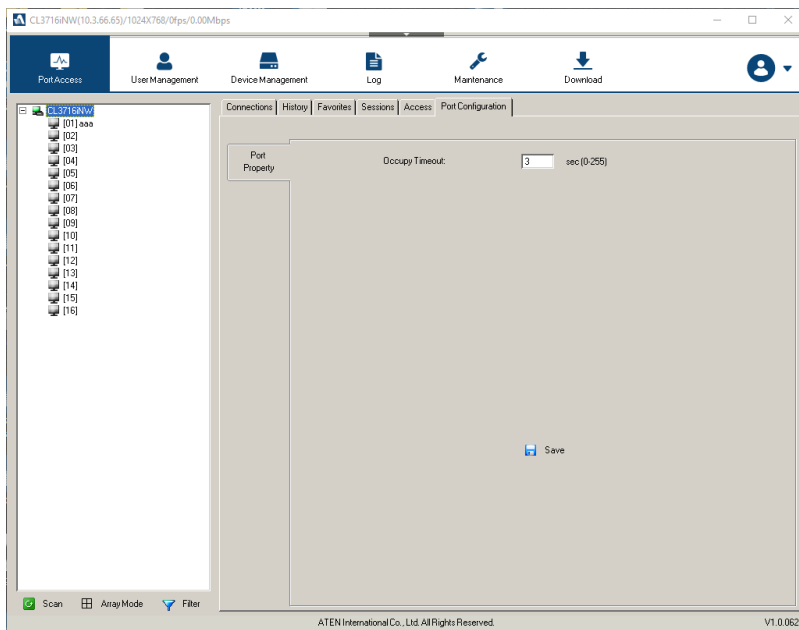

The Occupy Timeout field sets a time threshold for users on ports whose Access Mode has been set to Occupy (see *Access Mode*, page 138). If there is no activity from the user occupying the port for the amount of time set here, the user is timed out and the port is released. The first user to send keyboard or mouse input after the port has been released gets to occupy the port.

Input a value from 0 to 255 seconds. The default is 3 seconds. A setting of 0 causes the port to be released the instant there is no input.

Port Level

Port Properties

When a port is selected in the Sidebar, the Port Properties page looks similar to the one below:

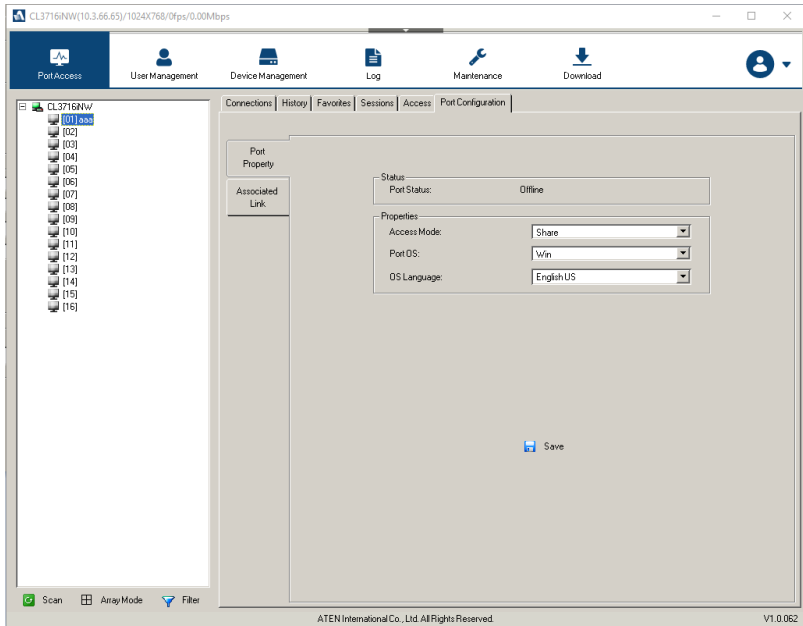

- ◆ The *Status* panel provides information as to whether or not the port is online or offline; the Adapter cable used to connect the server (or other device) to the port; and the Adapter's firmware level.
- ◆ The *Properties* panel allows you to make configuration settings for the selected port. An explanation of the Port Properties configuration fields is given on the next page, please refer to the table on page 138 for further details.

An explanation of the configuration fields is given in the table, below:

Field	Explanation
Access Mode	<p>Defines how the port is to be accessed when multiple users have logged on, as follows:</p> <p>Exclusive: The first user to switch to the port has exclusive control over the port. No other users can view the port. The <i>Timeout</i> function does not apply to ports which have this setting.</p> <p>Occupy: The first user to switch to the port has control over the port. However, additional users may view the port's video display. If the user who controls the port is inactive for longer than the time set in the <i>Timeout</i> box, port control is transferred to the first user to move the mouse or strike the keyboard.</p> <p>Share: Users simultaneously share control over the port. Input from the users is placed in a queue and executed chronologically. Under these circumstances, users can take advantage of the <i>Message Board</i>, which allows users to communicate with each other regarding control of the keyboard and mouse or keyboard, mouse, and video of a Share port (see <i>The Message Board</i>, page 100).</p>
Port OS	<p>Specifies the operating system that the server on the connected port is using. Choices are Win, Mac, Sun, and Other. The default is Win.</p>
OS Language	<p>Specifies the OS language being used by the server on the connected port. Drop down the list to see the available choices. The default is English US.</p>

When you have finished making your configuration changes, click **Save**.

Associated Links

The Associated Links page provides a method of associating other ports on the same switch to the selected port.

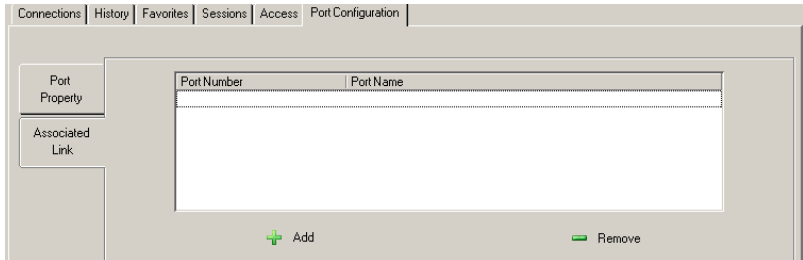

- ◆ To associate a port with the currently selected one, click **Add**. In the dialog box that appears, key in the port's number, then click **OK**. The port's number and name appear in the main panel.
- ◆ To remove an unwanted associated port, select it in the main panel, then click **Remove**.

Chapter 10

User Management

Overview (CL3708i / CL3716i Only)

When you select the *User Management* tab the screen comes up with the *Users* page displayed:

Browser GUI

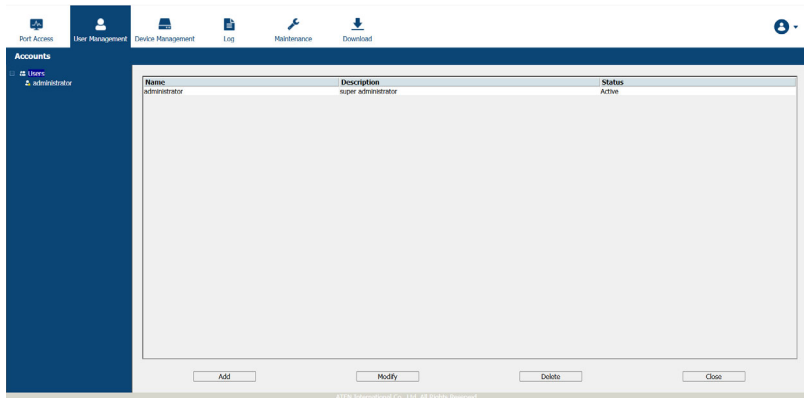

AP GUI

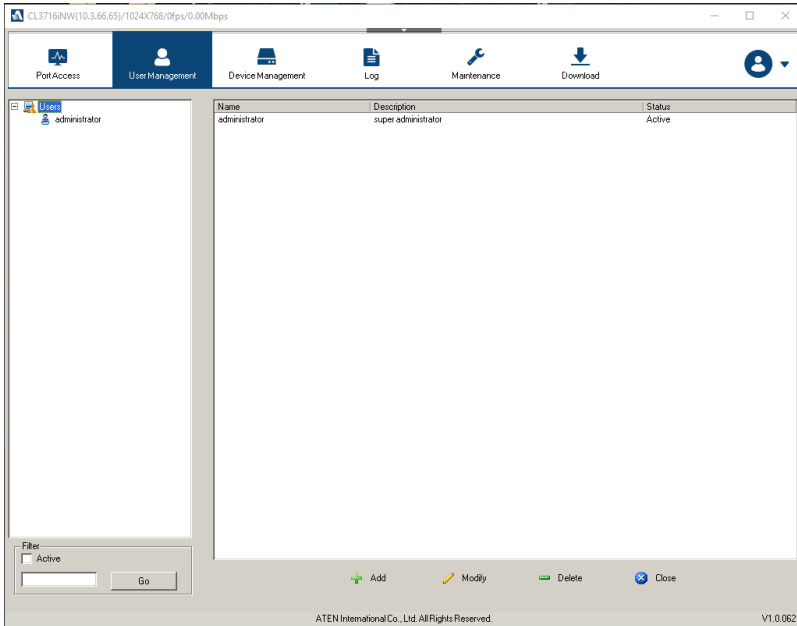

The page is organized into two main areas: the Sidebar at the left, and the large main panel at the right.

- ◆ Users and groups appear in the panel at the left of the page. The large panel at the right provides more detailed information at-a-glance for each.
 - ◆ The Browser GUI has separate menu bar entries for Accounts (Users) and Groups. Depending on the menu item selected, either Users or Groups are listed in the Sidebar.
 - ◆ The AP GUI doesn't have menu entries. Instead, Users and Groups are listed separately in the Sidebar
- ◆ In the Browser GUI, the sort order of the information displayed can be changed by clicking the main panel column headings.
- ◆ In the AP GUI, the section below the Sidebar list provides a filter that allows you to manage the list:



- ◆ Click to put a check in the *Active* checkbox to filter out any users whose accounts are not active.
- ◆ To only select Users or Groups that match a particular string, key it into the text box in front of the **Go** button, then click **Go**. Only Users or Groups that match the string will appear in the list.
Wildcards (? for single characters; * for multiple characters) and the keyword **or** are supported. E.g., h*ds would return hands and hoods; h?nd would return hand and hind, but not hard; h*ds or h*ks would return hands and hooks.
- ◆ The buttons below the main panel are used to manage users and groups, as shown in the sections that follow.

Users

The LCD KVM over IP switch supports three types of user, as shown in the table, below:

User Type	Role
Super Administrator	Access and manage ports and devices. Manage Users, and Groups. Configure the overall installation. Configure personal working environment.
Administrator	Access and manage authorized ports and devices. Manage Users and Groups. Configure personal working environment.
User	Access authorized ports and devices. Manage authorized ports and devices; configure personal working environment. Note: Users who have been given permission to do so, may also manage other users.

Adding Users

To add a user, and assign user permissions, do the following:

1. Select *Users* on the menu bar (Browser GUI)

– or –

Select *Users* in the Sidebar (AP GUI).

- Click **Add** at the bottom of the main panel. The User notebook opens, with the *User* tab selected:

The screenshot shows a web-based user management interface. At the top, there are two tabs: 'User' (selected) and 'Devices'. The main content area is a form with several sections:

- User Information:** Four text input fields for 'Username:', 'Password:', 'Confirm Password:', and 'Description:'.
- Role:** Three radio buttons: 'Super Administrator', 'Administrator', and 'User' (which is selected).
- Permissions:** A grid of checkboxes:
 - Device Management (unchecked)
 - Maintenance (unchecked)
 - Windows Client (checked)
 - Port Configuration (unchecked)
 - System Log (unchecked)
 - Java Client (checked)
 - User Management (unchecked)
 - View only (unchecked)
 - Force to Grayscale (unchecked)
- Status:** A group of checkboxes:
 - Disable account (unchecked)
 - Account never expires (selected)
 - Account expires on (radio button, followed by a text input field)
 - User must change password at next logon (unchecked)
 - User cannot change password (unchecked)
 - Password never expires (selected)
 - Password expires after (radio button, followed by a numeric input field containing '30')

At the bottom right of the form, there is a blue 'Save' button.

- Enter the required information in the appropriate fields. A description of each of the fields is given in the table below:

Field	Description
Username	From 1 to 16 characters are allowed depending on the Account Policy settings. See <i>Security Level</i> , page 177.
Password	From 0 to 32 characters are allowed depending on the Account Policy settings. See <i>Security Level</i> , page 177.

Field	Description
Confirm Password	To be sure there is no mistake in the password, you are asked to enter it again. The two entries must match.
Description	Additional information about the user that you may wish to include.
Role	<p>There are three categories: Super Administrator, Administrator and User. There is no limitation on the number of accounts that can be created in each category.</p> <ul style="list-style-type: none"> ◆ The Super Administrator is responsible for the overall installation configuration and maintenance; user management; and device and port assignments. The Super Administrator's permissions (see page 147) are automatically assigned by the system and cannot be altered. ◆ The default permissions for Administrators include everything except <i>Force to Grayscale</i>, but the permissions can be altered for each Administrator by checking or unchecking any of the permissions checkboxes. ◆ The default permissions for Users include the Win, Java, and SSH clients, but the permissions can be altered for each User by checking or unchecking any of the permissions checkboxes. <p>Note: Users who have been given User Management privileges cannot access or configure Groups.</p>

Field	Description
<p>Permissions</p> <p>For ordinary users, in addition to enabling <i>Device Management</i>, <i>Port Configuration</i>, and <i>Maintenance</i> permissions, the user must also be given those rights for each device and port that he will be allowed to manage. See <i>Device Assignment</i>, page 150 for details.</p>	<ul style="list-style-type: none"> ◆ Enabling <i>Device Management</i> allows a user to configure and control the settings for overall LCD KVM over IP switch operations (see <i>Device Management</i>, page 155). ◆ Enabling <i>Port Configuration</i> allows a user to configure and control the settings for individual ports (see <i>Port Configuration</i>, page 136). ◆ Enabling <i>User Management</i> allows a user to create, modify, and delete user and group accounts. ◆ Enabling <i>Maintenance</i> allows a user to perform all the Maintenance operations available under the Maintenance tab (see <i>Maintenance</i>, page 189). ◆ Enabling <i>System Log</i> allows a user to access the system log (see <i>Log</i>, page 183). ◆ Enabling <i>View Only</i> limits users to only being able to view the display of connected devices. They cannot control port access, nor can they input any keyboard or mouse signals to the devices they view. ◆ Enabling <i>Windows Client</i> allows a user to download the Windows Client AP software, and access the LCD KVM over IP switch with it, in addition to (or instead of) the browser access method. ◆ Enabling <i>Java Client</i> allows a user to download the Java Client AP software, and access the LCD KVM over IP switch with it, in addition to (or instead of) the browser access method. ◆ Enabling <i>Force to Greyscale</i> forces the remote display into gray scale view

Field	Description
Status	<p>Status allows you to control the user's account and access to the installation, as follows:</p> <ul style="list-style-type: none"> ◆ <i>Disable Account</i> lets you suspend a user's account without actually deleting it, so that it can be easily reinstated in the future. ◆ If you don't want to limit the time scope of the account, select <i>Account never expires</i>; if you do want to limit the amount of time that the account remains in effect, select <i>Account expires on</i>, and key in the expiration date. ◆ If you want to limit the time scope of the account, select <i>Account expires on</i>, and set the date and time allowed before the account expires. ◆ To require a user to change his password at the next logon, select <i>User must change password at next logon</i>. This can be used by the administrator to give the user a temporary password to log in for the first time, and then let the user set the password of his choice for future logins. ◆ To make a password permanent, so that the user cannot change it to something else, select <i>User cannot change password</i>. ◆ For security purposes, administrators may want users to change their passwords from time to time. <ul style="list-style-type: none"> ◆ If not, select <i>Password never expires</i>. This allows users to keep their current passwords for as long as they like. ◆ If so, select <i>Password expires after</i>, and key in the number of days allowed before the password expires. Once the time is up, a new password must be set.

4. At this point you can also assign the user's port access rights by selecting the *Devices* tab – the *Devices* page is discussed on page 150.

Note: Optionally, you can skip this step now to add more users and create groups, and come back to it later.

5. When your selections have been made click **Save**.
6. When the *Operation Succeeded* message appears, click **OK**.

7. Click **Users** in the Sidebar to return to the main screen. The new user appears in the Sidebar list and in the main panel, as well.
 - ◆ The Sidebar *Users* list can expand and collapse. If the list is expanded, click the minus symbol (–) next to the *Users* icon to collapse it; if it is collapsed there is a plus symbol (+) next to the icon. Click the plus symbol to expand it.
 - ◆ The icon for super administrators has two black bands; the icon for administrators has one red band.
 - ◆ The large main panel shows the user's name; the description that was given when the account was created; and whether the account is currently active or has been disabled.

Modifying User Accounts

To modify a user account, do the following:

1. In the Sidebar *User* list, click the user's name

– or –

In the main panel, select the user's name

2. Click **Modify**.
3. In the *User* page that comes up, make your changes, then click **Save**.

Note: The *User* page is discussed on page 144; the *Devices* page is discussed on page 150.

Deleting User Accounts

To delete a user account do the following:

1. In the main panel, select the user's name.
2. Click **Delete**.
3. Click **OK**.

Device Assignment

When a user logs in to the LCD KVM over IP switch, the interface comes up with the Port Access page displayed. All the ports that the user is permitted to access are listed in the Sidebar at the left of the page. Access permissions for those ports and the devices connected to them are assigned on a port-by-port basis from the *User* or *Group* list on the Sidebar of the User Management page.

Assigning Device Permissions From the User's Notebook

To assign a device permissions to a user from the *User's* notebook, do the following:

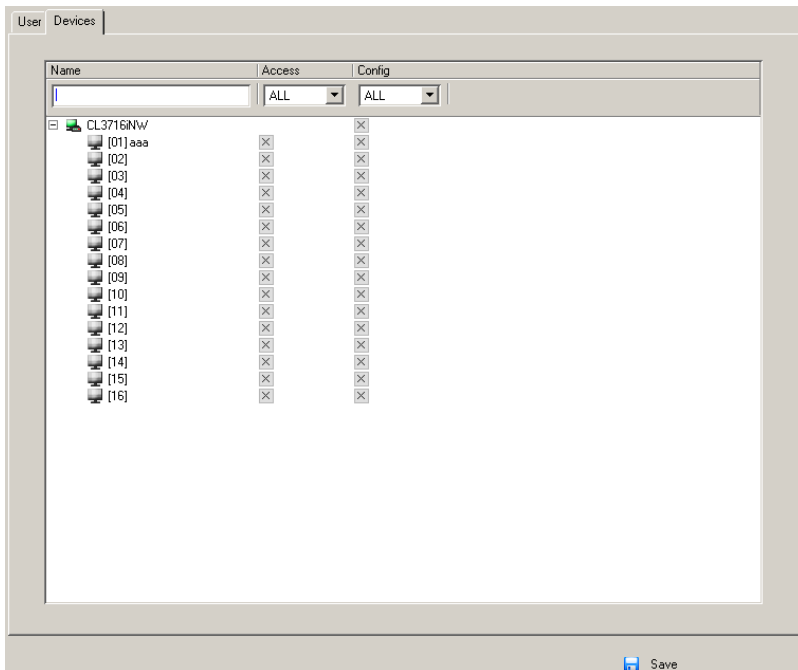

1. In the Sidebar *User* list, click the user's name
– or –
In the main panel, select the user's name.
2. Click **Modify**.
3. In the *User* notebook that comes up, select the *Devices* tab. A screen, similar to the one below, appears:



4. Make your permission settings for each port according to the information provided below:

Name: Each port accessible to the user is listed under the *Names* column.

Access: The *Access* column is where device access rights are set. Click the icon in the row that corresponds to the port you want to configure to cycle through the choices. The meanings of the icons are described in the table, below:

	Full Access	The user can view the remote screen and can perform operations on the remote server from his keyboard and monitor.
	View Only	The user can only view the remote screen; he cannot perform any operations on it.
	No Access	No access rights - the Port will not show up on the User's list on the Main Screen.

Config: The *Config* column is where a user's permission to make changes to a port's configuration settings are permitted/restricted. Click the icon in the row that corresponds to the port you want to configure to cycle through the choices.

A check mark () indicates that the user has permission to make changes to the port's configuration settings; an X means that the user is denied permission to make configuration changes.

5. When you have finished making your choices, click **Save**.
6. In the confirmation popup that appears, click **OK**.

Note: In any of the columns, you can use Shift-Click or Ctrl-Click to select a group of ports to configure. Clicking to cycle through the choices on any one of the selected ports causes all of them to cycle in unison.

Filters

There are three filters at the top of the columns that allow you to expand or limit the scope of the ports that are displayed in the *Name* column, as described in the following table:

Filter		Description
Name		To filter on the port name, key in the name then press Enter . Only the ports whose names correspond to what you have keyed in appear in the list. Wildcards (? for single characters; * for multiple characters) and the keyword or are supported. E.g., h*ds would return hands and hoods; h?nd would return hand and hind, but not hard; h*ds or h*ks would return hands and hooks.
Access	All	All ports appear in the list.
	Full Access	Only ports configured as Full Access ports appear in the list.
	View Only	Only ports configured as View Only ports appear in the list.
	No Access	Only ports configured as No Access ports appear in the list.
Config	All	All ports appear in the list.
	Permitted	Only ports configured as Permitted appear in the list.
	Restricted	Only ports configured as Restricted appear in the list.

Assigning Device Permissions From the Groups' Notebook

To assign a device permissions to a Group of users, do the following:

1. In the Sidebar *Groups* list, click the group's name

– or –

In the main panel, select the group's name.

2. Click **Modify**.
3. In the *Groups* notebook that comes up, select the *Devices* tab.
4. The screen that comes up is the same one that appears in the User's notebook. The only difference is that whatever settings you make apply to all members of the group instead of just one individual member.

Make your device assignments according to the information described under *Assigning Device Permissions From the User's Notebook*, page 150.

Chapter 11

Device Management

KVM Devices (CL3708i / CL3716i Only)

Device Information

The Device Management page opens with the top level LCD KVM over IP switch selected in the Sidebar and the *Device Information* item selected on the menu bar:

Browser GUI

The screenshot shows the Browser GUI interface. The top navigation bar includes icons for Port Access, User Management, Device Management (active), Log, Maintenance, and Download. Below the navigation bar, there are tabs for Device Information, Operating Mode, Network, ANMS, Security, and Date/Time. The main content area displays the following device information:

General	
Device Name:	CL3716NW
MAC Address:	00-10-74-04-20-04
Firmware Version:	V1.0.062.8a620251021
IP Address:	10.3.66.55
Subnet Mask:	255.255.255.0
Gateway:	10.3.66.254
Preferred DNS Server:	10.0.1.6
Alternate DNS Server:	10.0.1.7
IPv6 Address:	FE80:0:0:210:74FF:FE04:2004
IPv6 Subnet Prefix Length:	0

At the bottom of the interface, it says "ATEN International Co., Ltd. All Rights Reserved." and has a "Close" button.

AP GUI

The screenshot shows the AP GUI interface. The top navigation bar includes icons for Port Access, User Management, Device Management (active), Log, Maintenance, and Download. Below the navigation bar, there are tabs for Device Information, Operating Mode, Network, ANMS, Security, and Date/Time. The main content area displays the following device information:

General	
Device Name:	CL3716NW
MAC Address:	00-10-74-04-20-04
Firmware Version:	V1.0.062.8a620251021
IP Address:	10.3.66.55
Subnet Mask:	255.255.255.0
Gateway:	10.3.66.254
Preferred DNS Server:	10.0.1.6
Alternate DNS Server:	10.0.1.7
IPv6 Address:	FE80:0:0:210:74FF:FE04:2004
IPv6 Subnet Prefix Length:	0

At the bottom of the interface, it says "ATEN International Co., Ltd. All Rights Reserved." and has "Save" and "Close" buttons.

General

The *General* section of the Device Information page displays the name of the selected device, its firmware version and information about its network configuration.

Note: The AP GUI version presents the same information as the Browser version. Scroll through the list to see the additional entries.

Operating Mode

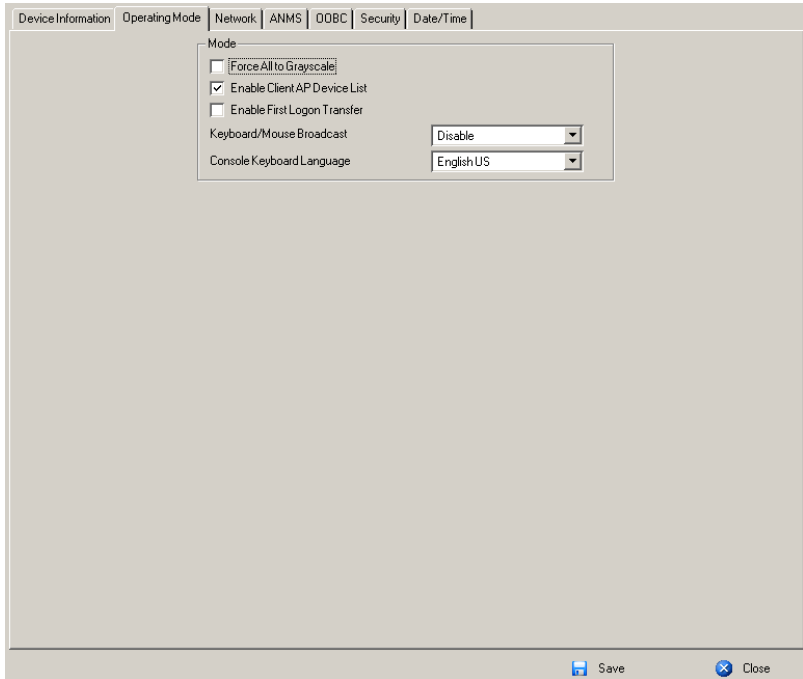

The Operating Mode page is used to set working parameters, as described below:

- ◆ If *Force all to grayscale* is enabled, the remote displays of all devices connected to the LCD KVM over IP switch are changed to grayscale. This can speed up I/O transfer in low bandwidth situations.
- ◆ If *Enable Client AP Device List* is enabled, the switch appears in the Server List when using the WinClient or Java Client AP (see *Windows Client AP Login*, page 69, and *Java Client AP Login*, page 73). If this option is not

enabled, the switch can still be connected to, but its name will not appear in the Server List.

- ◆ If *Enable First Logon Transfer* is enabled, only the first user on a bus can switch ports. Other users on the bus cannot switch ports unless there is a bus that is already connected to the port they would like to access, or there is a free bus available. (For details regarding users and buses.
- ◆ For *Keyboard/Mouse Broadcast*, drop-down the list to make your choice.
 - ◆ If you enable Keyboard Broadcast, your keystrokes will be duplicated on all the attached servers that currently appear in the Sidebar.
 - ◆ If you enable Mouse Broadcast, your mouse movements and clicks will be duplicated on all attached servers currently in the Sidebar.

Note: 1. On a KVM switch that is cascaded from the LCD KVM over IP switch, only one port can perform a Keyboard/Mouse broadcast at a time.

2. For Mouse Broadcast, you and all the servers must be running the same OS; all the monitors must have the same resolution; and all the screens must have an identical layout.

- ◆ The *Console Keyboard Language* setting lets you specify which keyboard mapping is being used by the Local Console keyboard. Drop down the list to make your choice.

Network

The Network page is used to specify the network environment.

Each of the elements on this page is described in the sections that follow.

IP Installer

Enabled
 View Only
 Disabled

Service Ports

Program:
 HTTP:
 HTTPS:

NIC Settings

IPv4 Settings

IP Address:

Obtain IP address automatically [DHCP]
 Set IP address manually [Fixed IP]

IP Address:

Subnet Mask:

Default Gateway:

DNS Server:

Obtain DNS server address automatically
 Set DNS server address manually

Preferred DNS server:

Alternate DNS server:

Network Transfer Rate: KBps

IPv6 Settings

IP Address:

Obtain IPv6 address automatically [DHCP]
 Set IPv6 address manually [Fixed IP]

IPv6 Address:

Subnet Prefix Length:

Default Gateway:

DNS Server:

Obtain DNS server address automatically
 Set DNS server address manually

Preferred DNS server:

Alternate DNS server:

IP Installer

The IP Installer is an external Windows-based utility for assigning IP addresses to the LCD KVM over IP switch.

Click one of the radio buttons to select *Enable*, *View Only*, or *Disable* for the IP Installer utility.

-
- Note:**
1. If you select *View Only*, you will be able to see the LCD KVM over IP switch in the IP Installer's Device List, but you will not be able to change the IP address.
 2. For security, we strongly recommend that you set this to *View Only* or *Disable* after each use.
-

Service Ports

As a security measure, if a firewall is being used, the Administrator can specify the port numbers that the firewall will allow. If a port other than the default is used, users must specify the port number as part of the IP address when they log in. If an invalid port number (or no port number) is specified, the LCD KVM over IP switch will not be found. An explanation of the fields is given in the table below:

Field	Explanation
Program	This is the port number for connecting with the WinClient ActiveX Viewer, WinClient AP, Java Client Viewer, Java Client AP, or via Virtual Media. The default is 9000.
HTTP	The port number for a browser login. The default is 80.
HTTPS	The port number for a secure browser login. The default is 443.

-
- Note:**
1. Valid entries for all of the Service Ports are from 1–65535.
 2. Service ports cannot have the same value. You must set a different value for each one.
 3. If there is no firewall (on an Intranet, for example), it doesn't matter what these numbers are set to, since they have no effect.
-

NIC Settings

- ◆ IPv4 Settings

- ◆ IP Address:

IPv4 is the traditional method of specifying IP addresses. The LCD KVM over IP switch can either have its IP address assigned dynamically (DHCP), or it can be given a fixed IP address.

- ◆ For dynamic IP address assignment, select the *Obtain IP address automatically* radio button. (This is the default setting.)
 - ◆ To specify a fixed IP address, select the *Set IP address manually* radio button and fill in the fields with values appropriate for your network.

Note: 1. If you choose *Obtain IP address automatically*, when the switch starts up it waits to get its IP address from the DHCP server. If it hasn't obtained the address after one minute, it automatically reverts to its factory default IP address (192.168.0.60.)

2. If the switch is on a network that uses DHCP to assign network addresses, and you need to ascertain its IP address.
-

- ◆ DNS Server

- ◆ For automatic DNS Server address assignment, select the *Obtain DNS Server address automatically* radio button.
 - ◆ To specify the DNS Server address manually, select the *Set DNS server address manually* radio button, and fill in the addresses for the Preferred and Alternate DNS servers with values appropriate for your network.

Note: Specifying the Alternate DNS Server address is optional.

- ◆ IPv6 Settings
 - ◆ IP Address:

IPv6 is the new (128-bit) format for specifying IP addresses. The LCD KVM over IP switch can either have its IPv6 address assigned dynamically (DHCP), or it can be given a fixed IP address.

 - ◆ For dynamic IP address assignment, select the *Obtain IP address automatically* radio button. (This is the default setting.)
 - ◆ To specify a fixed IP address, select the *Set IP address manually* radio button and fill in the fields with values appropriate for your network.
 - ◆ DNS Server
 - ◆ For automatic DNS Server address assignment, select the *Obtain DNS Server address automatically* radio button.
 - ◆ To specify the DNS Server address manually, select the *Set DNS server address manually* radio button, and fill in the addresses for the Preferred and Alternate DNS servers with values appropriate for your network.

Note: Specifying the Alternate DNS Server address is optional.

Network Transfer Rate

This setting allows you to tailor the size of the data transfer stream to match network traffic conditions by setting the rate at which the LCD KVM over IP switch transfers data between itself and the client computers. The range is from 4–99999 Kilobytes per second (KBps).

Finishing Up

After making any network changes, be sure *Reset on exit* on the *Device Management* → *System Operation* page (see *Reset on exit.*, page 198) has been enabled (there is a check in the checkbox), before logging out. This allows network changes to take effect without having to power the switch off and on.

ANMS

The ANMS (Advanced Network Management Settings) page is used to set up login authentication and authorization management from external sources. It is organized as a notebook with two tabs – each with a series of related panels, as described, below:

Event Destination

The screenshot shows the ANMS configuration interface. The 'Event Destination' tab is selected in the sidebar. The main configuration area is divided into several sections:

- SMTP Settings:**
 - Enable report from the following SMTP Server
 - SMTP Server: [Text Field]
 - Service Port: [Text Field] (value: 25)
 - My server requires secure connection (SSL)
 - My server requires authentication
 - Account Name: [Text Field]
 - Password: [Text Field]
 - From: [Text Field]
 - To: [Text Field]
- Log Server:**
 - Enable
 - MAC Address: [Text Field] (value: 000000000000)
 - Service Port: [Text Field] (value: 9001)
- SNMP Server:**
 - Enable SNMP Agent
 - Server IP: [Text Field]
 - Service Port: [Text Field] (value: 162)
- Syslog Server:**
 - Enable
 - Server IP: [Text Field]
 - Service Port: [Text Field] (value: 514)

At the bottom right of the window, there are 'Save' and 'Close' buttons.

◆ SMTP Settings

To have the LCD KVM over IP switch email reports from the SMTP server to you, do the following:

1. Enable the *Enable report from the following SMTP server*, and key in either the IPv4 address, IPv6 address, or domain name of the SMTP server.
2. If your server requires a secure SSL connection, put a check in the *My server requires secure connection (SSL)* checkbox.

3. If your server requires authentication, put a check in the *My server requires authentication* checkbox, and key in the appropriate account information in the *Account Name* and *Password* fields.
4. Key in the email address of where the report is being sent from in the *From* field.

Note: 1. Only one email address is allowed in the *From* field, and it cannot exceed 64 Bytes.

2. 1 Byte = 1 English alphanumeric character.

5. Key in the email address (addresses) of where you want the SMTP reports sent to in the *To* field.

Note: If you are sending the report to more than one email address, separate the addresses with a semicolon. The total cannot exceed 256 Bytes.

◆ **Log Server**

Important transactions that occur on the LCD KVM over IP switch, such as logins and internal status messages, are kept in an automatically generated log file.

- ◆ Specify the MAC address of the computer that the Log Server runs on in the *MAC address* field.
- ◆ Specify the port used by the computer that the Log Server runs on to listen for log details in the *Port* field. The valid port range is 1–65535. The default port number is 9001.

Note: The port number must differ than the one used for the *Program* port (see *Program*, page 160).

See Chapter 16, *The Log Server*, for details on setting up the log server. The Log File is discussed on page 183.

- ◆ **SNMP Server**

To be notified of SNMP server events, do the following:

1. Check *Enable SNMP Agent*.
2. Key in either the IPv4 address, IPv6 address, or domain name of the computer to be notified of SNMP trap events.
3. Key in the port number. The valid port range is 1–65535.

Note: The logs that are notified of SNMP server events are configured on the Notification Settings page under the Log tab. See *Log Notification Settings*, page 221 for details.

- ◆ **Syslog Server**

To record all the events that take place on LCD KVM over IP switches and write them to a Syslog server, do the following:

1. Check **Enable**.
2. Key in either the IPv4 address, IPv6 address, or domain name of the Syslog server.
3. Key in the port number. The valid port range is 1-65535.

Authentication

Device Information | Operating Mode | Network | ANMS | Security | Date/Time

Event Destination

Authentication

Disable Device Authentication

RADIUS Settings:

Enable

Preferred RADIUS Server IP:

Preferred RADIUS Service Port:

Alternate RADIUS Server IP:

Alternate RADIUS Service Port:

Timeout: sec

Retries:

Shared Secret (at least 6 characters):

AD/LDAP Settings:

Enable

Type

LDAP LDAPS

LDAP Server: Port:

Admin DN: Timeout: sec

Admin Name:

Password:

Search DN:

CC Management:

Enable

CC Server IP: CC Service Port:

Save Close

- ◆ **Disable Local Authentication**

Selecting this option disables login authentication on the LCD KVM over IP switch. The switch can only be accessed using LDAP, LDAPS, MS Active Directory, RADIUS or CC Management authentication.

- ◆ **RADIUS Settings**

To allow authentication and authorization for the LCD KVM over IP switch through a RADIUS server, do the following:

1. Check **Enable**.
2. Select Preferred or Alternate RADIUS server.
3. Fill in the IP addresses and service port numbers for the Preferred and Alternate RADIUS servers. You can use the IPv4 address, the IPv6 address or the domain name in the IP fields.
4. Select the *Authentication Type*.
5. In the *Timeout* field, set the time in seconds that the LCD KVM over IP switch waits for a RADIUS server reply before it times out.

6. In the *Retries* field, set the number of allowed RADIUS retries.
7. In the *Shared Secret* field, key in the character string that you want to use for authentication between the LCD KVM over IP switch and the RADIUS Server. A minimum of 6 characters is required.
8. On the RADIUS server, Users can be authenticated with any of the following methods:
 - ◆ Set the entry for the user as **su/xxxx**
Where *xxxx* represents the Username given to the user when the account was created on the LCD KVM over IP switch.
 - ◆ Use the same Username on both the RADIUS server and the LCD KVM over IP switch.
 - ◆ Use the same Group name on both the RADIUS server and the LCD KVM over IP switch.
 - ◆ Use the same Username/Group name on both the RADIUS server and the LCD KVM over IP switch.

In each case, the user's access rights are the ones assigned that were assigned when the User or Group was created on the LCD KVM over IP switch. (See *Adding Users*, page 144.)

- ◆ AD / LDAPS Authentication and Authorization Settings

To allow authentication and authorization via AD or LDAPS, the Active Directory's LDAP Schema must be extended so that an extended attribute name for the CL3708NX / CL3708iNW / CL3716NX / CL3716iNW – *iKVM34-userProfile* is added as an optional attribute to the person class.

To manually find out the attribute name of the CL3708NX / CL3708iNW / CL3716NX / CL3716iNW – *iKVM34-userProfile*, go to *Terminal* under *Maintenance* and execute a **get** command, see *PingHost*, page 197 for details.

In order to configure the LDAP server, you will have to complete the following procedures:

1. Install the Windows Server Support Tools.
2. Install the Active Directory Schema Snap-in.
3. Extend and update the Active Directory Schema.

To allow authentication and authorization for the LCD KVM over IP switch via LDAP / LDAPS, refer to the information in the table, below:

Item	Action
Enable	Put a check in the <i>Enable</i> checkbox to allow LDAP / LDAPS authentication and authorization.
Type	Click a radio button to specify whether to use LDAP or LDAPS.
LDAP Server IP and Port	<p>Select Preferred or Alternate LDAP Server and fill in the IP address and port number for the LDAP or LDAPS server.</p> <ul style="list-style-type: none"> ◆ You can use the IPv4 address, the IPv6 address or the domain name in the <i>LDAP Server</i> field. ◆ For LDAP, the default port number is 389; for LDAPS, the default port number is 636.
Admin DN	<p>Consult the LDAP / LDAPS administrator to ascertain the appropriate entry for this field. For example, the entry might look like this:</p> <p style="text-align: center;">ou=kn8132,dc=aten,dc=com</p>
Admin Name	Key in the LDAP administrator's username.
Password	Key in the LDAP administrator's password.
Search DN	Set the distinguished name of the search base. This is the domain name where the search starts for user names.
Timeout	Set the time in seconds that the LCD KVM over IP switch waits for an LDAP or LDAPS server reply before it times out.

On the LDAP / LDAPS server, Users can be authenticated with any of the following methods:

- ◆ With MS Active Directory schema.
- ◆ Without schema – Only the Usernames used on the LCD KVM over IP switch are matched to the names on the LDAP / LDAPS server. User privileges are the same as the ones configured on the switch.

- ◆ Without schema – Only Groups in AD are matched. User privileges are the ones configured for the groups he belongs to on the switch.
- ◆ Without schema – Usernames and Groups in AD are matched. User privileges are the ones configured for the User and the Groups he belongs to on the switch.

Note: For more information on configuring LDAP, you can download the full LDAP instructional manual from our website.

CC Management Settings

To allow authorization for the LCD KVM over IP switch through a CC (Control Center) server, check *Enable* and fill in the CC Server's IP address and Service port in the appropriate fields. You can use the IPv4 address, the IPv6 address or the domain name in the *CC Server IP* field.

Security

The Security page is divided into 7 main panels, as described in the sections that follow.

The screenshot shows the Security configuration page with the following panels and settings:

- Device Information**: Operating Mode, Network, ANMS, Security, Date/Time
- Login Failures**:
 - Enable
 - Allowed: 5 Timeout: 3 min
 - Lock Client PC Lock Account
- Filter**:
 - Enable IP Filter Include Exclude
 - Buttons: Add, Modify, Delete
 - Login String:
 - Enable MAC Filter Include Exclude
 - Buttons: Add, Modify, Delete
- Account Policy**:
 - Minimum Username Length: 6
 - Minimum Password Length: 6
 - Password Must Contain At Least:
 - One Upper Case
 - One Lower Case
 - One Number
 - Disable Duplicate Login
- Security Level**:
 - High Medium-high Medium
 - Custom:
 - Enable JGMP service
 - Enable HTTP session
 - Enable HTTPS session
 - TLS 1.2,1.3
 - Note: you can use both HTTP and HTTPS to login.
- Working Mode**:
 - Enable Multiuser Operation
 - Disable Authentication
- Host Header Validation**:
 - Enable
 - Allowed:
- Private Certificate**:
 - Private Key: Browse...
 - Certificate: Browse...
 - Buttons: Upload, Restore default

Buttons at the bottom: Save, Close

Login Failures

For increased security, the Login Failures section allows administrators to set policies governing what happens when a user fails to log in successfully.

The Login Failures panel configuration is as follows:

- Enable
- Allowed: 5 Timeout: 3 min
- Lock Client PC Lock Account

To set the Login Failures policy, check the *Enable* checkbox (the default is for Login Failures to be enabled). The meanings of the entries are explained in the table below:

Entry	Explanation
Allowed	Sets the number of consecutive failed login attempts that are permitted from a remote computer. The default is 5 times.
Timeout	Sets the amount of time a remote computer must wait before attempting to login again after it has exceeded the number of allowed failures. The default is 3 minutes.
Lock Client PC	<p>If this is enabled, after the allowed number of failures have been exceeded, the computer attempting to log in is automatically locked out. No logins from that computer will be accepted. The default is enabled.</p> <p>Note: This function relates to the client computer's IP. If the IP is changed, the computer will no longer be locked out.</p>
Lock Account	If this is enabled, after the allowed number of failures have been exceeded, the user attempting to log in is automatically locked out. No logins from the username and password that have failed will be accepted. The default is enabled.

Note: If Login Failures is not enabled, users can attempt to log in an unlimited number of times with no restrictions. For security purposes, we recommend that you enable this function and enable the lockout policies.

Filter

The screenshot shows a 'Filter' configuration window. It is divided into two main sections: IP Filter and MAC Filter. Each section includes an 'Enable' checkbox, 'Include' and 'Exclude' radio buttons, a list box for filter entries, and 'Add', 'Modify', and 'Delete' buttons. A 'Login String' text field is positioned between the two filter sections.

- ◆ IP and MAC Filtering

IP and MAC Filters control access to the LCD KVM over IP switch based on the IP and/or MAC addresses of the client computers attempting to connect. A maximum of 100 IP filters and 100 MAC filters are allowed. If any filters have been configured, they appear in the IP Filter and/or MAC Filter list boxes.

To enable IP and/or MAC filtering, **Click** to put a check mark in the *IP Filter Enable* and/or *MAC Filter Enable* checkbox.

- ◆ If the include button is checked, all the addresses within the filter range are allowed access; all other addresses are denied access.
- ◆ If the exclude button is checked, all the addresses within the filter range are denied access; all other addresses are allowed access.

- ◆ Adding Filters

To add an IP filter, do the following:

1. Click **Add**. A dialog box similar to the one below appears:

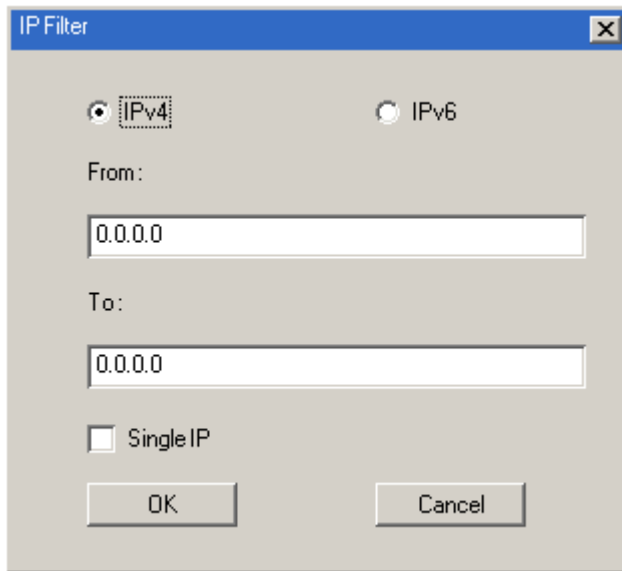

2. Specify whether you are filtering an IPv4 or IPv6 address.
3. Key the address you want to filter in the *From*: field.
 - ◆ To filter a single IP address, click to put a check in the *Single IP* checkbox.
 - ◆ To filter a continuous range of addresses, key in the end number of the range in the *To*: field.

Note: This description is for the AP GUI. The Browser GUI differs as follows:

1. It doesn't offer an IPv4 or IPv6 choice. It only has *From* and *To* fields for IPv4 filtering.
2. It doesn't have a checkbox to specify a single IP address. To filter a single IPv4 address, key the same address in both the *From* and *To* fields.

4. After filling in the address, click **OK**.
5. Repeat these steps for any additional IP addresses you want to filter.

To add a MAC filter, do the following:

1. Click **Add**. A dialog box similar to the one below appears:

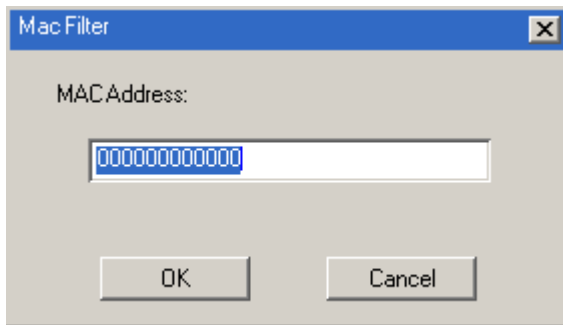

2. Specify the MAC address in the dialog box, then click **OK**.
 3. Repeat these steps for any additional MAC addresses you want to filter.
- ◆ **IP Filter / MAC Filter Conflict**

If there is a conflict between an IP filter and a MAC filter – in other words, if a computer's address is allowed by one filter but blocked by the other – then the blocking filter takes precedence (the computer's access is blocked).
 - ◆ **Modifying Filters**

To modify a filter, select it in the IP Filter or MAC Filter list boxes and click **Modify**. The Modify dialog box is similar to the Add dialog box. When it comes up, simply delete the old address(es) and replace it with the new one(s).
 - ◆ **Deleting Filters**

To delete a filter, select it in the IP Filter or MAC Filter list box and click **Delete**.

Login String

The *Login String* entry field lets the super administrator specify a login string (in addition to the IP address) that users must add to the IP address when they access the LCD KVM over IP switch with a browser.

For example, if *192.168.0.126* were the IP address, and *abcdefg* were the login string, then the user would have to key in:

```
192.168.0.126/abcdefg
```

-
- Note:**
1. Users must place a forward slash between the IP address and the string.
 2. If no login string is specified here, anyone will be able to access the LCD KVM over IP switch login page using the IP address alone. This makes your installation less secure.
-

The following characters are allowed in the string:

```
0-9 a-z A-Z ~ ! @ $ & * ( ) _ - = + [ ] .
```

The following characters are not allowed:

```
% ^ " : / ? # \ ' { } ; ' < > [Space]
```

Compound characters (É Ç ñ ... etc.)

For security purposes, we recommend that you change this string occasionally.

Account Policy

In the Account Policy section, system administrators can set policies governing usernames and passwords.

Account Policy

Minimum Username Length:

Minimum Password Length:

Password Must Contain At Least

One Upper Case

One Lower Case

One Number

Disable Duplicate Login

The meanings of the Account Policy entries are explained in the table below:

Entry	Explanation
Minimum Username Length	Sets the minimum number of characters required for a username. Acceptable values are from 1–16. The default is 6.
Minimum Password Length	Sets the minimum number of characters required for a password. Acceptable values are from 0–32. A setting of 0 means that no password is required. Users can login with only a Username. The default is 6.
Password Must Contain At Least	<p>Checking any of these items requires users to include at least one uppercase letter, one lowercase letter or one number in their password.</p> <p>Note: This policy only affects user accounts created after this policy has been enabled, and password changes to existing user accounts. Users accounts created before this policy was enabled, and there is no change to the existing passwords, are not affected.</p>
Disable Duplicate Login	Check this to prevent users from logging in with the same account at the same time.

Security Level

For increased security, you can check or uncheck the boxes to High, Medium-high, Medium or Custom security features.

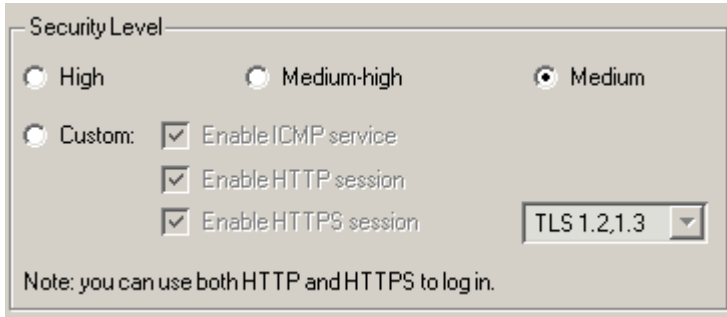

Security Level

High
 Medium-high
 Medium

Custom:
 Enable ICMP service
 Enable HTTP session
 Enable HTTPS session

TLS 1.2,1.3

Note: you can use both HTTP and HTTPS to login.

1. High (Disable all services except: SSHv2, HTTPS(TLS v1.2))
2. Medium-high (Enables SSHv2, redirect HTTP to HTTPS, HTTPS(TLS v1.2), ICMP)
3. Medium (Enables SSHv2, redirect HTTP to HTTPS, HTTPS(TLS v1.0, 1.1, 1.2), SNMP Agent, ICMP) **(Default)**
4. Custom: Click to check the following security options you wish to apply:
 - ◆ Enable ICMP service
 - ◆ Enable HTTP session
 - ◆ Enable HTTPS session (Select between “TLS 1.3”, “TLS 1.2, 1.3”, “TLS 1.0, 1.1, 1.2, 1.3”.)

Working Mode

Working Mode

Enable Multiuser Operation

Disable Authentication

An explanation of the Mode items is given in the table, below:

Item	Explanation
Enable Multiuser Operation	Enabling <i>Multiuser operation</i> permits up to 32 users to log in at the same time to share the remote bus. If not enabled, only one user can log in at a time. The default is Enabled.
Disable Authentication	If <i>Disable Authentication</i> is checked, no authentication procedures are used to check users attempting to log in. Users gain Administrator access to the LCD KVM over IP switch simply by entering combination of username and password. Note: Enabling this setting creates an extremely dangerous result as far as security goes, and should only be used under very special circumstances.

Host Header Validation

Host Header Validation

Enable

Allowed:

For enhanced security with the web servers and applications, enable the Host Header Validation and specify the allowed hosts.

Private Certificate

When logging in over a secure (SSL) connection, a signed certificate is used to verify that the user is logging in to the intended site. For enhanced security, the *Private Certificate* section allows you to use your own private encryption key and signed certificate, rather than the default ATEN certificate.

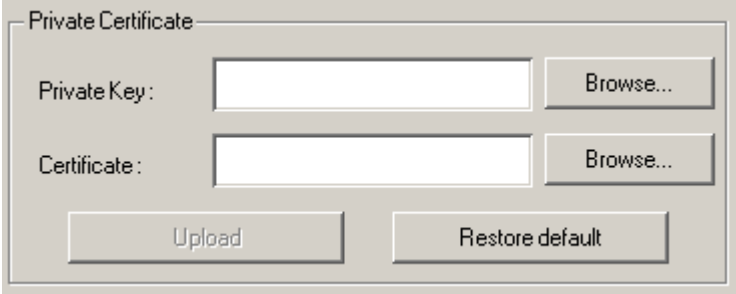
A screenshot of a 'Private Certificate' configuration dialog box. The dialog has a title bar 'Private Certificate'. It contains two rows of input fields. The first row is labeled 'Private Key:' and has a text input field followed by a 'Browse...' button. The second row is labeled 'Certificate:' and has a text input field followed by a 'Browse...' button. At the bottom of the dialog, there are two buttons: 'Upload' and 'Restore default'.

There are two methods for establishing your private certificate: generating a self-signed certificate; and importing a third-party certificate authority (CA) signed certificate.

- ◆ **Generating a Self-Signed Certificate**

If you wish to create your own self-signed certificate, a free utility – `openssl.exe` – is available for download over the web.

- ◆ **Obtaining a CA Signed SSL Server Certificate**

For the greatest security, we recommend using a third party certificate authority (CA) signed certificate. To obtain a third party signed certificate, go to a CA (Certificate Authority) website to apply for an SSL certificate. After the CA sends you the certificate and private encryption key, save them to a convenient location on your computer.

- ◆ **Importing the Private Certificate**

To import the private certificate, do the following:

1. Click **Browse** to the right of *Private Key*; browse to where your private encryption key file is located; and select it.
2. Click **Browse** to the right of *Certificate*; browse to where your certificate file is located; and select it.
3. Click **Upload** to complete the procedure.

-
- Note:** 1. Clicking **Restore Default** returns the device to using the default ATEN certificate.
2. Both the private encryption key and the signed certificate must be imported at the same time.
-

Date/Time

The Date/Time dialog page sets the LCD KVM over IP switch time parameters:

The screenshot shows the 'Date/Time' configuration window. At the top, there are tabs: 'Device Information', 'Operating Mode', 'Network', 'ANMS', 'Security', and 'Date/Time'. The 'Date/Time' tab is selected.

Time Zone: A dropdown menu is set to '(GMT+12:00) Eniwetok Kwajalein'. Below it is an unchecked checkbox for 'Daylight Savings Time'.

Date: A calendar for December 2025 is displayed. The date '30' is selected and highlighted in blue.

Time: The time is set to '18 : 20 : 56'. A 'Set' button is located to the right of the time input.

Network Time: This section has an unchecked checkbox for 'Enable auto adjustment'. Below it, there are two 'Preferred time server' and 'Alternate time server' dropdown menus, both set to 'AU|ntp1.cs.mu.OZ.AU'. Each dropdown has an unchecked checkbox for 'Preferred custom server IP' and 'Alternate custom server IP' respectively. At the bottom, there is an 'Adjust time every' field set to '1' days and an 'Adjust Time Now' button.

At the bottom right of the dialog, there are 'Save' and 'Close' buttons.

Set the parameters according to the information below.

Time Zone

- ◆ To establish the time zone that the LCD KVM over IP switch is located in, drop down the *Time Zone* list and choose the city that most closely corresponds to where it is at.
- ◆ If your country or region employs Daylight Saving Time (Summer Time), check the corresponding checkbox.

Date

- ◆ Select the month from the drop down listbox.
- ◆ Click < or > to move backward or forward by one year increments.
- ◆ In the calendar, click on the day.
- ◆ To set the time, use the 24 hour HH:MM:SS format.
- ◆ Click **Set** to save your settings.

Network Time

To have the time automatically synchronized to a network time server, do the following:

1. Check the *Enable auto adjustment* checkbox.
2. Drop down the time server list to select your preferred time server
– or –
Check the *Preferred custom server IP* checkbox, and key in either the IPv4 address, IPv6 address, or domain name of the time server of your choice.
3. If you want to configure an alternate time server, check the *Alternate time server* checkbox, and repeat step 2 for the alternate time server entries.
4. Key in your choice for the number of days between synchronization procedures.
5. If you want to synchronize immediately, click **Adjust Time Now**.

Chapter 12

Log

Overview (CL3708i / CL3716i Only)

The LCD KVM over IP switch logs all the events that take place on it. To view the contents of the log, click the *Log* tab. The device's Log Information page, similar to the one below, appears:

Browser GUI

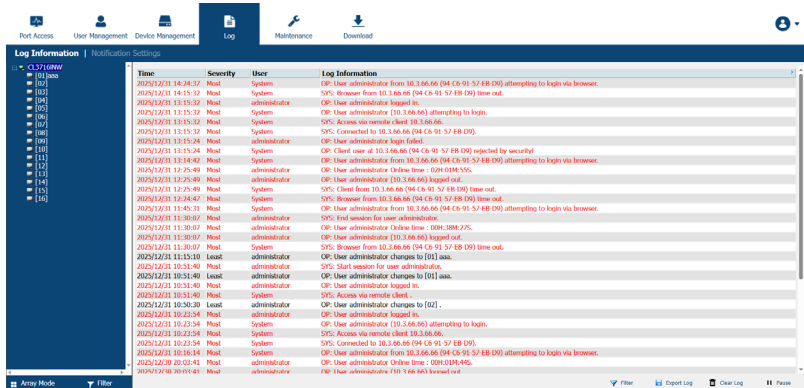

AP GUI

The screenshot displays the ATEN AP GUI interface. The top navigation bar includes icons for Port Access, User Management, Device Management, Log (selected), Maintenance, and Download. The main content area is titled 'Log' and shows a list of events with columns for Time, Severity, User, and Log Information. The left sidebar shows a tree view with 'CL3716NW' selected and a sub-item '[01]aaa'. At the bottom, there are controls for Scan, Airaj Mode, Filter, Pause, Clear Log, Export Log, and Filter. The footer contains 'ATEN International Co., Ltd. All Rights Reserved.' and 'V1.0.062'.

Time	Severity	User	Log Information
2025/12/31 14:24:37	Most	System	DP: User administrator from 10.3.66.66 [94-C6-91-57-EB-D9] attempting to login via browser
2025/12/31 14:15:32	Most	System	SYS: Browser from 10.3.66.66 [94-C6-91-57-EB-D9] time out.
2025/12/31 13:15:32	Most	administrator	DP: User administrator logged in.
2025/12/31 13:15:32	Most	System	DP: User administrator [10.3.66.66] attempting to login
2025/12/31 13:15:32	Most	System	SYS: Access via remote client 10.3.66.66.
2025/12/31 13:15:32	Most	System	SYS: Connected to 10.3.66.66 [94-C6-91-57-EB-D9].
2025/12/31 13:15:24	Most	administrator	DP: User administrator login failed.
2025/12/31 13:15:24	Most	System	DP: Client user at 10.3.66.66 [94-C6-91-57-EB-D9] rejected by security!
2025/12/31 13:14:42	Most	System	DP: User administrator from 10.3.66.66 [94-C6-91-57-EB-D9] attempting to login via browser.
2025/12/31 12:25:49	Most	administrator	DP: User administrator Online time : 02h 01M 55S.
2025/12/31 12:25:49	Most	administrator	DP: User administrator [10.3.66.66] logged out.
2025/12/31 12:25:49	Most	System	SYS: Client from 10.3.66.66 [94-C6-91-57-EB-D9] time out.
2025/12/31 12:24:47	Most	System	SYS: Browser from 10.3.66.66 [94-C6-91-57-EB-D9] time out.
2025/12/31 11:45:31	Most	System	DP: User administrator from 10.3.66.66 [94-C6-91-57-EB-D9] attempting to login via browser.
2025/12/31 11:30:07	Most	administrator	SYS: End session for user administrator.
2025/12/31 11:30:07	Most	administrator	DP: User administrator Online time : 00h 38M 27S.
2025/12/31 11:30:07	Most	administrator	DP: User administrator [10.3.66.66] logged out.
2025/12/31 11:30:07	Most	System	SYS: Browser from 10.3.66.66 [94-C6-91-57-EB-D9] time out.
2025/12/31 11:15:10	Least	administrator	DP: User administrator changes to [01]aaa
2025/12/31 10:51:40	Most	administrator	SYS: Start session for user administrator.
2025/12/31 10:51:40	Least	administrator	DP: User administrator changes to [01]aaa
2025/12/31 10:51:40	Most	administrator	DP: User administrator logged in.
2025/12/31 10:51:40	Most	System	SYS: Access via remote client.
2025/12/31 10:50:30	Least	administrator	DP: User administrator changes to [02].
2025/12/31 10:23:54	Most	administrator	DP: User administrator logged in.
2025/12/31 10:23:54	Most	System	DP: User administrator [10.3.66.66] attempting to login.
2025/12/31 10:23:54	Most	System	SYS: Access via remote client 10.3.66.66.
2025/12/31 10:23:54	Most	System	SYS: Connected to 10.3.66.66 [94-C6-91-57-EB-D9].
2025/12/31 10:16:14	Most	System	DP: User administrator from 10.3.66.66 [94-C6-91-57-EB-D9] attempting to login via browser.
2025/12/30 20:03:41	Most	administrator	DP: User administrator Online time : 00h 01M 44S.
2025/12/30 20:03:41	Most	administrator	DP: User administrator [10.3.66.66] logged out.
2025/12/30 20:01:57	Most	administrator	DP: User administrator logged in.
2025/12/30 20:01:57	Most	System	DP: User administrator [10.3.66.66] attempting to login.
2025/12/30 20:01:57	Most	System	SYS: Access via remote client 10.3.66.66.
2025/12/30 20:01:57	Most	System	SYS: Connected to 10.3.66.66 [94-C6-91-57-EB-D9].

Log Information

The Log Information page displays events that take place on the LCD KVM over IP switch, and provides a breakdown of the time, the severity, the user, and a description of each one. You can change the sort order of the display by clicking on the column headings.

The log file tracks a maximum of 512 events. When the limit is reached, the oldest events get discarded as new events come in. The purpose of the buttons at the bottom of the page are described in the following table:

Button	Explanation
Pause	Clicking <i>Pause</i> stops the display of new events. When the display is paused the button changes to <i>Resume</i> . Click Resume to start displaying events again.
Clear Log	Clicking <i>Clear Log</i> clears the log file.
Export Log	Clicking <i>Export Log</i> lets you save the contents of the log to a file on your computer.
Filter	Clicking <i>Filter</i> allows you to search for particular events by date or by specific words or strings, as described in the next section.

Filter

Filter lets you narrow the log event display to ones that occurred at specific times; ones containing specific words or strings; or ones involving specific users. When you access this function, the log filter dialog box appears at the bottom of the page:

Display Options

Time: Start Date/Time... End Date/Time... Today Only

Information: User Device Time

Priority: Least Less Most

A description of the filter items is given in the table, below:

Item	Description
Time	<p>This feature lets you filter for events that occurred at specific times, as follows:</p> <p>Today Only: Only the events for the current day are displayed.</p> <p>Device Time: Shows the events according to the time configure on the switch.</p> <p>Start Date/Time: Filters for events from a specific date and time to the present. Put a check in the checkbox to bring up a calendar. Set the date and time that you want the filtering to start from. All events from the Start date/time to the present are displayed.</p> <p>For the Web Browser interface, after checking Start Date/Time, you have to click inside the text box in order to bring up the calendar. When you have made your calendar choices, click the A icon at the lower right of the calendar panel.</p> <p>End Date/Time: Filters for events from a specific date and time to a specific date and time. First select the Start Date/Time (described above); check End Date/Time to set the ending date and time.</p> <p>For the Web Browser interface, after checking End Date/Time, you have to click inside the text box in order to bring up the calendar. When you have made your calendar choices, click the A icon at the lower right of the calendar panel.</p>
Information	<p>Filters for a particular word or string. Key the word or string into the <i>Information</i> text box. Only events containing that word or string are displayed. Wildcards (? for single characters; * for multiple characters) and the keyword or are supported. E.g., h*ds would return hands and hoods; h?nd would return hand and hind, but not hard; h*ds or h*ks would return hands and hooks.</p>

Item	Description
User	<p>Filters for specific users. First put a check in the <i>User</i> checkbox; then key in the user's Username; then click Apply. Only events containing that Username are displayed.</p> <p>Note: If the <i>User</i> checkbox is not checked here in the Filter panel, the entire User column does not appear in the main panel.</p>
Severity	<p>Filters based on the severity rating of the event. Least events appear in black; Less events appear in blue; Most events appear in red.</p> <p>First put a check in the <i>Severity</i> checkbox; then check the severity options you want to filter for (you can check more than one item). Only events that match the severity ratings you specified appear in the display.</p> <p>Note: If the <i>Severity</i> checkbox is not checked here in the Filter panel, the entire Severity column does not appear in the main panel.</p>
Apply	Click to apply the filter choices.
Reset	Click this button to clear the entries in the dialog box and start with a clean slate.
Exit	Click this button to exit the log filter function.

Log Notification Settings

The Notification Settings page lets you decide which events trigger a notification, and how the notification are sent out:

The screenshot shows a web interface titled "Notification Settings" with a "Log" tab. It contains a table with the following columns: "Event", "SNMP", "SMTP", and "SysLog". The table lists various events, each with a checkmark (X) in the columns for the notification methods it is enabled for. A "Save" button is located at the bottom right of the table area.

Event	SNMP	SMTP	SysLog
[-] Authentication events			
Login	X	X	X
Login fail	X	X	X
User locked	X	X	X
IP address locked	X	X	X
Logout	X	X	X
End Session	X	X	X
Browser Viewer started	X	X	X
Browser Viewer ended	X	X	X
[-] KVM Viewer events			
Viewer switch port	X	X	X
[-] Device events			
Modify Port Configuration	X	X	X
Add user	X	X	X
User information modified	X	X	X
Delete user	X	X	X
Operation settings modified	X	X	X
Network settings modified	X	X	X
ANMS settings modified	X	X	X
Notification settings modified	X	X	X
Security settings modified	X	X	X
Time settings modified	X	X	X
IP changed	X	X	X
Log Server connection failed	X	X	X
Certificate uploaded	X	X	X
Default certificate restored	X	X	X
Invalid IP access	X	X	X
Invalid MAC access	X	X	X
NTP succeeded	X	X	X
NTP failed	X	X	X
Log deleted	X	X	X
Device FW Upgrade succeeded	X	X	X

Notifications can be sent via SNMP trap, SMTP email, written to the SysLog file, or any combination of the three. A check mark (✓) indicates that notification of the event is enabled for the method specified in the column heading; an X indicates that notification is not enabled.

Note: In any of the columns, you can use Shift-Click or Ctrl-Click to select a group of events. Clicking to enable/disable any one of them causes all of them to change in unison.

Chapter 13

Maintenance

Overview (CL3708i / CL3716i Only)

The *Maintenance* function is used to upgrade firmware; backup and restore configuration and account information; ping network devices; and restore default values.

Browser GUI

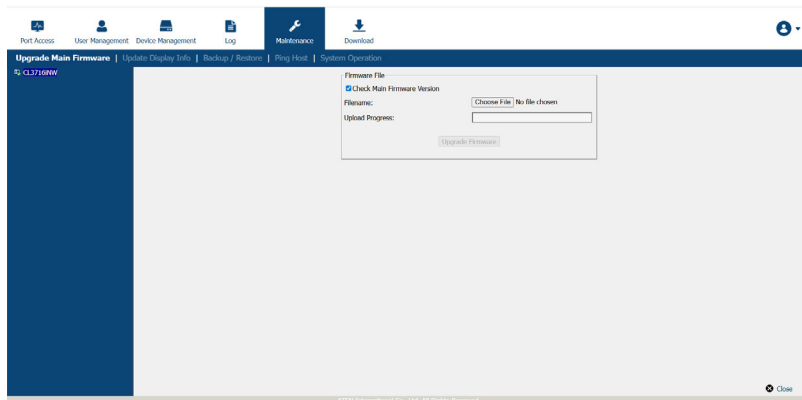

AP GUI

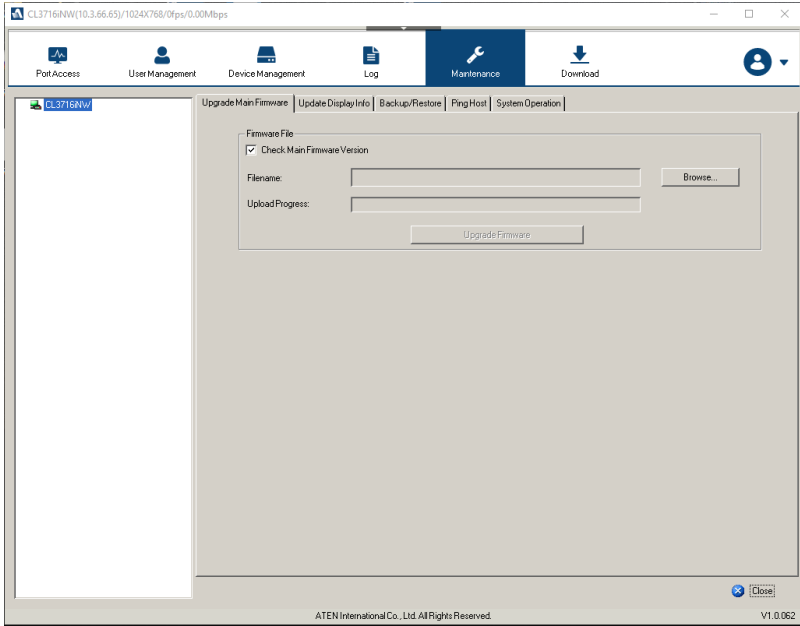

Main Firmware Upgrade

In addition to upgrading the LCD KVM over IP switch's main firmware, this function can also be used to upgrade any PoN units and Blade Servers deployed on the installation. As new versions of the firmware become available, they can be downloaded from our website. Check the website regularly to find the latest information and packages.

To upgrade the main firmware, do the following:

1. Download the new firmware file (switch, PoN or blade server module), to your computer.
2. Log in to the LCD KVM over IP switch; and click the *Maintenance* tab. The Maintenance tab opens to the *Upgrade Main Firmware* page:

3. Click **Browse**; navigate to the directory that the new firmware file is in and select the file.
4. Click **Upgrade Firmware** to start the upgrade procedure.
 - ◆ If you enabled *Check Main Firmware Version* the current firmware level is compared with that of the upgrade file. If the current version is equal to or higher than the upgrade version, a popup message appears, to inform you of the situation and stops the upgrade procedure.
 - ◆ If you didn't enable *Check Main Firmware Version*, the upgrade file is installed without checking what its level is.
 - ◆ As the upgrade proceeds, progress information is shown in the *Progress* bar.
 - ◆ Once the upgrade completes successfully, the switch resets itself.
5. Log in again, and check the firmware version to be sure it is the new one.

Note: To recover from a “failed upgrade” situation, see *Recovering from Failed Firmware Upgrade*, page 192.

Recovering from Failed Firmware Upgrade

Should the switch's main firmware upgrade procedure fail, and the switch becomes unusable, follow the steps below to resolve the problem:

1. Power off the switch.
2. Press and hold the reset button in (see *reset button*, page 11).
3. While holding the reset button in, power the switch back on.

This causes the switch to use the original factory installed main firmware version. Once the switch is operational, you can try upgrading the main firmware again by logging on to the KVM over IP switch via web browser (see *Main Firmware Upgrade*, page 191).

Update Display Info

The *Update Display Info* page allows you to view and update the local monitor's EDID information and update it onto the display. The EDID information tells the server's video card about the hardware of the display it is connected to; in this case the monitor connected to the KVM console.

Browser GUI

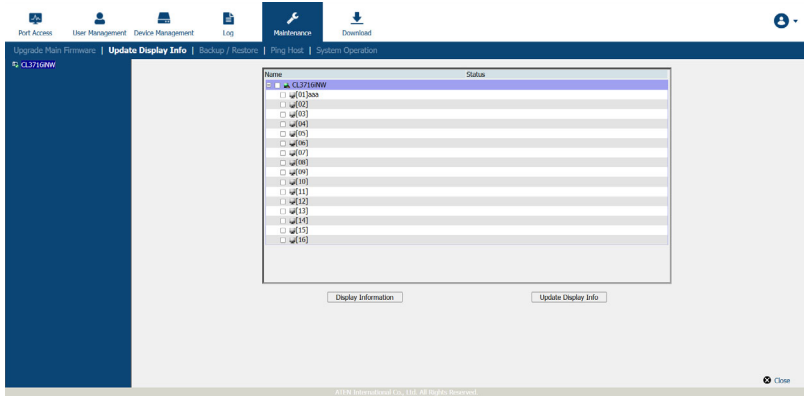

AP GUI

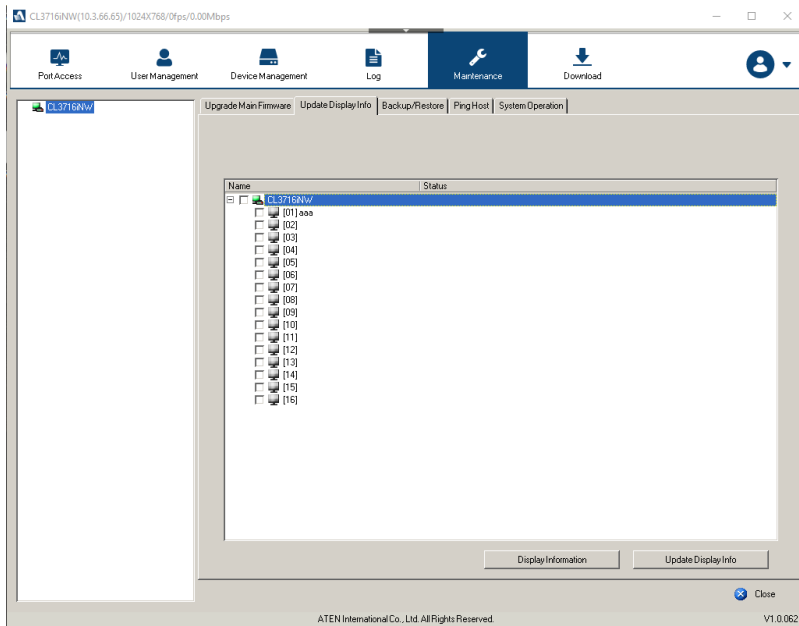

Item	Description
Display Information	Displays the display information.
Update Display Info	Clicks to select a preferred resolution and click Update to update it onto the display.

Backup/Restore

Selecting the Backup/Restore menu item gives you the ability to back up the switch's configuration and user profile information:

The screenshot shows a web-based interface for backup and restore operations. It is split into two main panels. The top panel, labeled 'Backup', contains a 'Password:' text input field and a 'Backup' button below it. The bottom panel, labeled 'Restore', contains a 'Filename:' text input field with a 'Choose...' button to its right, an 'Upload progress:' progress bar, another 'Password:' text input field, and three radio buttons: 'Select All' (selected), 'User Account', and 'User Select'. Below these is an 'Options' section with a grid of checkboxes: 'Device Information', 'ANMS', 'Operating Mode', 'Account', 'Network', 'Security', and 'Date/Time', all of which are checked. A 'Restore' button is located at the bottom of the interface.

Backup

To backup the device's settings do the following:

1. In the *Password* field, key in a password for the file.

Note: 1. Setting a password is optional. If you do not set one, the file can be restored without specifying a password.

2. If you do set a password, make a note of it, since you will need it to be able to restore the file.
-

2. Click **Backup**.
3. When the browser asks what you want to do with the file, select *Save to disk*; then save it in a convenient location.

Restore

To restore a previous backup, do the following:

1. Click **Browse**; navigate to the file and select it.

Note: If you renamed the file, you can leave the new name. There is no need to return it to its original name.

2. If you set a password when you created the file, key it in the *Password* field.
3. Select as many of the options that are presented as you wish to restore.
4. Click **Restore**.

After the file is restored, a message appears to inform you that the procedure succeeded.

PingHost

PingHost allows you to ping a device's IP address by entering the hostname or IP address, and view or configure options.

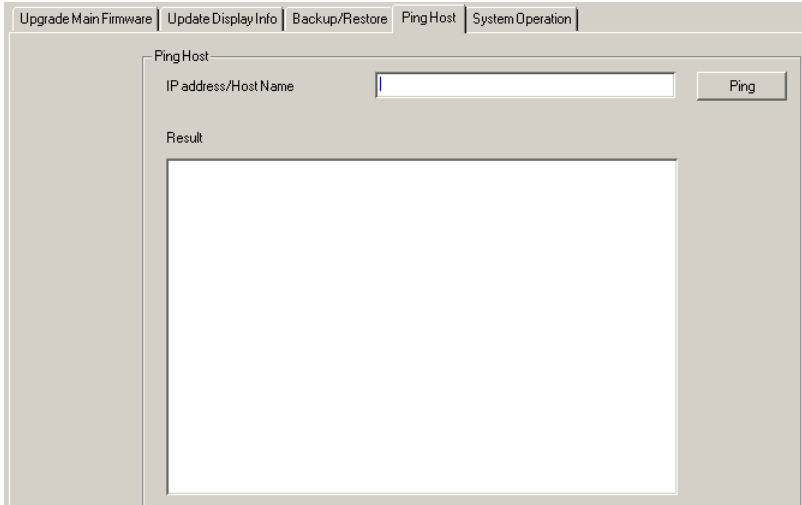

Available commands include:

- ◆ ENBLERC4 => Enable RC4 cipher.
- ◆ ENABLESSLV2 => Enables SSLv2 protocol.
- ◆ ENABLESSLV3 => Enables SSLv3 protocol.
- ◆ ENABLETLSV1.0 => Enables/disables TLSv1.0 protocol.
- ◆ ENABLETLSV1.1 => Enables/disables TLSv1.1 protocol.
- ◆ GET => Gets current configuration.
- ◆ HELP => Provides Help information for commands.
- ◆ SETLDAPMEMBER => Sets new value for ldap member.
- ◆ SETLDAPMEMBEROF => Sets new value for ldap memberof.
- ◆ SETPROMPT => Sets prompt string.
- ◆ SETSSLCIPHER => Sets SSL cipher strength.

Restore Values

The Restore Values page lets you restore certain configuration changes that were made to the LCD KVM over IP switch back to their original factory default values.

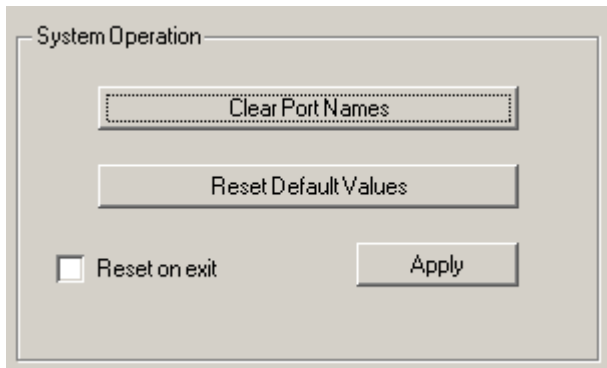

The functions performed on this page are as follows:

Clear Port Names:

Clicking this button removes names that have been assigned to the ports

Restore Default Values:

Clicking this button undoes all Customization page changes that have been made to the LCD KVM over IP switch (except for the Port Names), as well as the Network Transfer Rate (on the Network page), and returns the parameters to the original factory default settings.

Reset on exit:

Place a check here and click **Apply** to have the LCD KVM over IP switch reset itself and implement all the new settings when you log out. (Following the reset, wait approximately 30 to 60 seconds before logging back in.)

If you change the switch's IP Address (see *Network*, page 159), the checkbox is automatically checked and the KVM switch will reset when you log out. If you clear the check mark before logging out, the changed IP settings will be ignored and the original IP address settings will remain in effect.

Note: Even though the changed IP settings are ignored, they still remain in the network settings fields. Which means that the next time you open this page the *Reset on exit* checkbox will automatically be enabled, and when the switch

resets, the new IP settings that you thought you discarded will become the ones used by the switch. To avoid this problem, you should go back to the network settings page and be sure that the IP settings that appear in the fields are the ones you want to use.

Chapter 14

Download

Overview (CL3708i / CL3716i Only)

Download is used to download stand-alone AP versions of the Windows Client, the Java Client, and the Log Server:

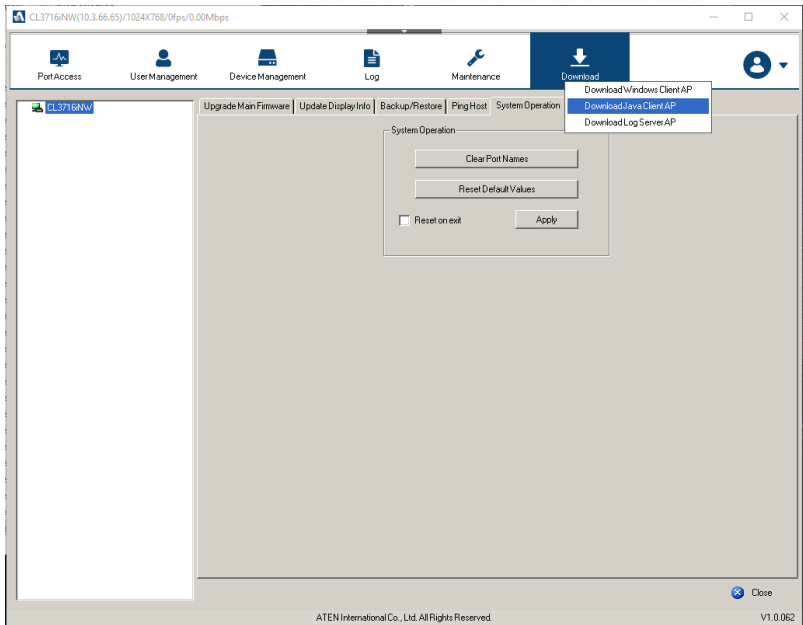

Click the program you want to download; save it to a convenient location on your hard disk, and run it from there.

Chapter 15

Port Operation

Overview (CL3708i / CL3716i Only)

After you have successfully logged in (*Logging In*, page 67), the LCD KVM over IP switch opens to the Port Access tab's Connections page, with the first LCD KVM over IP switch selected in the sidebar:

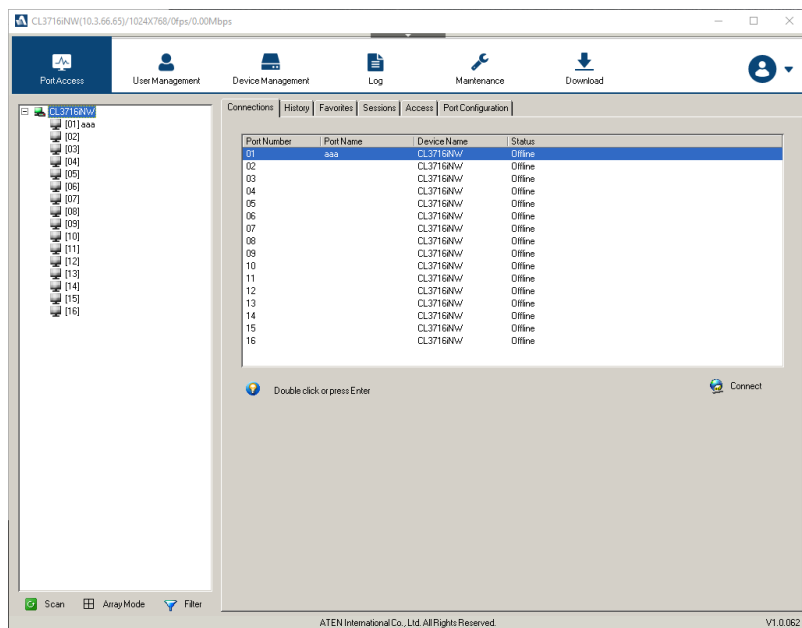

- Note:**
1. The WinClient and Java Client AP programs have a hidden Control Panel at the upper center of the screen that becomes visible when you mouse over it. The Browser version's Control Panel only appears after you switch to a port. The Control Panel is discussed on *The Control Panel*, page 87.
 2. See *KVM Devices and Ports – Connections Page*, page 121 for details about the Port Access *Connections* page.
-

Connecting to a Port

All the devices, ports, and outlets that a user is permitted to access are listed in the Sidebar at the left of the page.

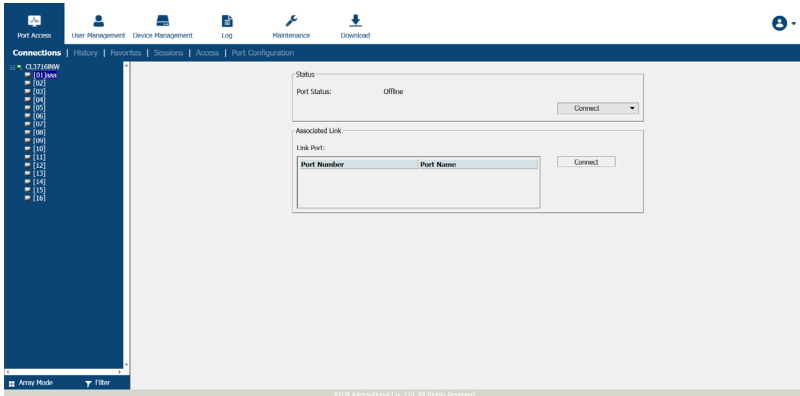

When connecting to a port, you can choose the *Viewer* automatically or manually.

Automatic selection: Double click the port (on the sidebar) or click **Connect** after selecting a port.

- ◆ The system automatic selects the preferred viewer from the *Viewer* option in the *User Preferences* page. Refer to *Viewer Preference* on page 82 for more information.

Manual selection: Click the drop-down menu on the right of the **Connect** button and select the preferred viewer.

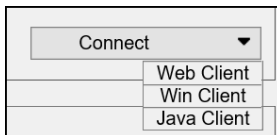

Once connected, its screen displays on your monitor, and your keyboard and mouse input affects the remote server:

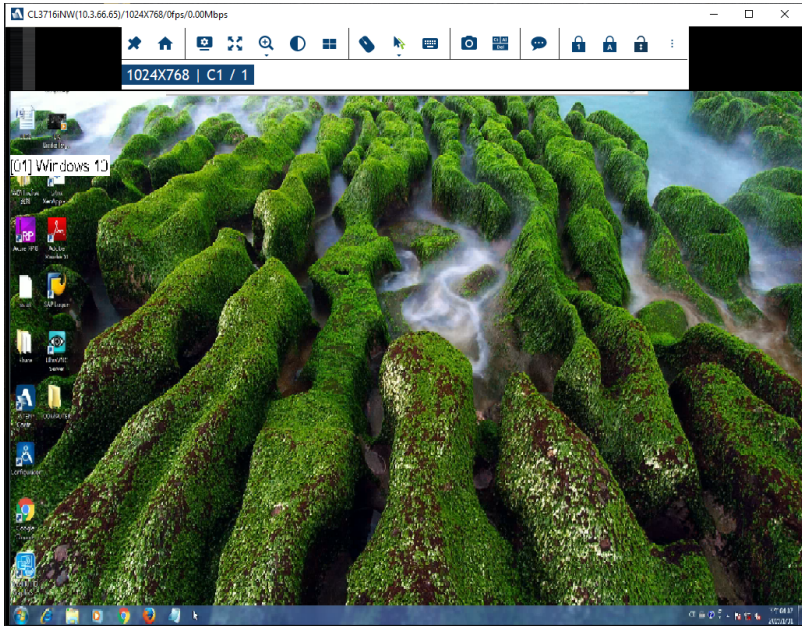

The Port Toolbar

The LCD KVM over IP switch's interface provides a toolbar to help you with port switching operations from within the captured port. To bring up the toolbar, tap the OSD hotkey (Scroll Lock or Ctrl), twice. The toolbar appears at the upper left corner of the screen:



Depending on the settings that were selected for ID Display (see page 80), the Port Number and/or the Port Name display at the right of the toolbar. The meanings of the toolbar icons are given in a table on page 207.









When the toolbar displays mouse and keyboard input has no effect on the server connected to the port. To carry out operations on the server, close the toolbar by clicking its **X** icon.

To return to the Port Access *Connections* page, either click the appropriate icon (see *The Toolbar Icons*, page 207), or tap the OSD hotkey again.

-
- Note:**
1. You can adjust the toolbar transparency (see *Video Settings*, page 91).
 2. The toolbar functions and icons are also incorporated in the Control Panel. If you choose to enable them in the Control Panel (see *Customize Control Panel Configuration*, page 105), you can disable the Toolbar (see *Sessions*, page 128 for details). To recall the Port Access *Connections* page when there is no Toolbar, simply tap the OSD hotkey twice.
-

The Toolbar Icons

The meanings of the toolbar icons are explained in the table below.

Icon	Purpose
	Click to skip to the first accessible port on the entire installation, without having to recall the Port Access page.
	Click to skip to the first accessible port previous to the current one, without having to recall the Port Access page.
	Click to begin Auto Scan Mode. The LCD KVM over IP switch automatically switches among the ports that were selected for Auto Scanning with the <i>Filter</i> function (<i>Filter</i> , page 116). This allows you to monitor their activity without having to switch among them manually.
	Click to skip from the current port to the next accessible one, without having to recall the Port Access page.
	Click to skip from the current port to the last accessible port on the entire installation, without having to recall the Port Access page.
	Click to recall the Port Access page.
	Click to close the toolbar.
	Click to invoke Panel Array Mode (see <i>Panel Array Mode</i> , page 211).

Toolbar Hotkey Port Switching

When the toolbar displays, you can use hotkeys to provide KVM focus to a port directly from the keyboard. The LCD KVM over IP switch provides the following hotkey features:

- ◆ Going directly to a port by keying in its port number and clicking **Enter**.
- ◆ Auto Scanning
- ◆ Skip Mode Switching

The hotkeys are: **A** and **P** for Auto Scanning; and the **Arrow Keys** for Skip Mode.

-
- Note:**
1. In order for hotkey operations to take place, the toolbar must be visible (see *The Port Toolbar*, page 206).
 2. To use the keys designated as hotkeys (i.e. A, P, etc.) for normal, non-hotkey purposes, you must first close the toolbar.
 3. For issues affecting multiple user operation in Auto Scan Mode, see *Multiuser Operation*, page 214.
-

Auto Scanning

The Scan function automatically switches among all the ports that are accessible to the currently logged on user at regular intervals, so that the user can monitor their activity automatically. Users can also limit the number of ports scanned with the Filter function of the Sidebar. See *KVM Devices and Ports – Connections Page*, page 121, and *Filter*, page 116, for further details.

- ◆ Setting the Scan Interval:

The amount of time Auto Scan dwells on each port is set with the *Scan Duration* setting (see *Scan Duration*, page 80).

- ◆ Invoking Auto Scan

To start Auto Scanning, with the toolbar showing, tap the **A** key. The Auto Scan function cycles through the ports in order – starting from the first port on the installation. An appears in front of the Port ID Display to indicate that the port is being accessed under Auto Scan Mode.

- ◆ Pausing Auto Scan

While you are in Auto Scan Mode, you can pause the scanning in order to keep the focus on a particular server by pressing **P**. During the time that Auto Scanning is paused, the **S** in front of the Port ID blinks On and Off.

Pausing when you want to keep the focus on a particular server can be more convenient than exiting Auto Scan Mode because when you *Resume* scanning, you start from where you left off. If, on the other hand, you were to exit and then restart Auto Scan Mode, the scanning would start over from the very first server on the installation.

To *Resume* Auto Scanning after a pause, press any key except [Esc] or the [Spacebar]. Scanning continues from where it left off.

- ◆ Exiting Auto Scan

While Auto Scan Mode is in effect, ordinary keyboard functions are suspended. You must exit Auto Scan Mode in order to regain normal control of the keyboard. To exit Auto Scan Mode press [Esc] or the [Spacebar]. Auto Scanning stops when you exit Auto Scan Mode.

Skip Mode

Skip Mode allows you to switch ports in order to monitor the servers manually. You can dwell on a particular port for as long or as little as you like - as opposed to Auto Scanning, which automatically switches after a fixed interval. The Skip Mode hotkeys are the four Arrow keys. Their operation is explained in the table below:

Arrow	Action
←	Skips from the current port to the first accessible port previous to it.
→	Skips from the current port to the first accessible port that comes after it.
↑	Skips from the current port to the very first accessible port on the installation.
↓	Skips from the current port to the very last accessible port on the installation.

Recalling the Port Access Page

To dismiss the toolbar and bring back the Port Access page, do one of the following:

- ◆ Tap the OSD hotkey once.
- ◆ From the toolbar, click the icon that recalls the Port Access page (see *The Toolbar Icons*, page 207).

The toolbar closes, and the Port Access Page appears.

Hotkey Summary Table

The following table presents a summary of the OSD hotkey actions after you have accessed a port. See *Sessions*, page 128 to set the OSD hotkey.

To...		Do This...
Open the Toolbar		Tap the OSD hotkey twice
Open the Port Access Page	The Toolbar is open	Tap the OSD hotkey once
	The Toolbar is not open	Tap the OSD hotkey three times

Panel Array Mode

Clicking the toolbar's *Panel* icon invokes Panel Array Mode. Under this mode, the screen divides into a grid of up to 64 panels:

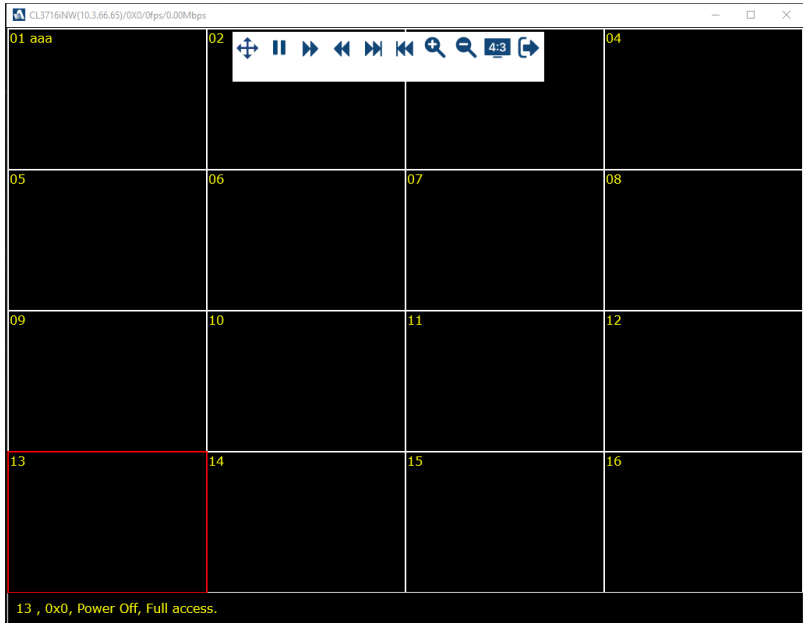











- ◆ Each panel represents one of the switch's ports beginning with Port 1 at the upper left, and going from left to right; top to bottom.
- ◆ The number of panels in the array can be selected by clicking the **Show More Ports**, and **Show Fewer Ports** symbols on the panel array toolbar (see the following page for an explanation of the panel array toolbar).
- ◆ When the Array is first invoked, it scans through each of the ports that were selected for Auto Scanning with the *Filter* function (see *Filter*, page 116). As it scans, the border of the panel that has the focus becomes highlighted.
- ◆ Only ports that are accessible to the user are displayed. For ports that are not accessible, the panel is blank.
- ◆ If the server connected to a port is on line, its screen displays in its panel, otherwise the panel is blank.
- ◆ Mousing over a panel displays information about the port (port name, online status, port access status, and resolution).

- ◆ You can access a server connected to a port by moving the mouse pointer over its panel and clicking. You switch to the server exactly as if you had selected it from the Port Access page.

Panel Array Toolbar

The panel array toolbar provides shortcut navigation and control of the panel array. The toolbar can be dragged anywhere on the screen. Mousing over an icon brings up a “tooltip” that provides a short description of the icon’s function. The icon functions are described in the table below:

Control	Description
	Click and drag to move the toolbar. Note: This icon is only available with the Windows Clients. To move the Java Client toolbars, click on any empty space and drag.
	Pause panel scanning, leaving the focus on the panel that currently has it.
	Move back four panels.
	Move to the previous panel.
	Move to the next panel.
	Move ahead four panels.
	Show More Ports: Increase the number of panels in the array.
	Show Fewer Ports: Decrease the number of panels in the array.
	Toggle 4/3 aspect ratio.
	Exit Panel Array mode.

Note: When Panel Array Mode is being used by one of the members of the bus, independent bus switching does not work. For rules of multiple user operation and bus usage in Panel Array Mode, see *Multiuser Operation*, page 214.

Multuser Operation

The LCD KVM over IP switch supports multuser operation. When multiple users simultaneously access the switch from client computers, the rules of precedence that apply are shown in the following table:

Operation	Rule
General	The switches utilize a single shared bus implementation - although they support local and remote login at the same time, they do not support independent operation. If a local user logs in while a remote user has already opened a session, the local user sees the same screen that the remote user is working on.
Auto Scan Mode	<p>If a user has invoked Auto Scan Mode (see page 208), and then another user logs on, at first the new user sees the GUI Main Page – but as soon as he accesses any port, he automatically enters Auto Scan Mode (since he is sharing the bus with the original user).</p> <p>Any user can halt Auto Scan Mode by recalling the GUI Main Page. When this occurs, Auto Scan Mode stops and all the other users on the bus are switched to the port that was being accessed when Auto Scan Mode stopped.</p>
Panel Array Mode	<ul style="list-style-type: none"> ◆ If a user has invoked Panel Array Mode (see page 211), and then another user logs on, the new user sees the GUI Main Page – but as soon as he accesses any port, he automatically enters Panel Array Mode (since he is sharing the bus with the original user). ◆ Panel Array Mode continues until the original user stops it. (Administrators can override Panel Array Mode, however.) ◆ Only the user who starts Panel Array Mode can use the Skip Mode (see page 209), function. ◆ Only the user who starts Panel Array Mode can switch ports. Other users automatically switch to the ports that the original user selects. However, if one of the other users does not have access rights to the port that the original user switches to, that user will not be able to view the port. ◆ Individual users can increase or decrease the number of panels they wish to view in Panel Array Mode; however, the picture quality may decrease as the number of panels increases.

Chapter 16

The Log Server

The Windows-based Log Server is an administrative utility that records all the events that take place on selected LCD KVM over IP switches and writes them to a searchable database. This chapter describes how to install and configure the Log Server.

Installation (CL3708i / CL3716i Only)

1. Log into the LCD KVM over IP switch (*Logging In*, page 67).
2. Click the *Download* tab and download the Log Server AP program.
3. Go to the location on your hard disk that you downloaded the Log Server program to, and double click its icon (*LogSetup.exe*) to bring up the Windows Client Connection Screen:

Note: If the browser cannot run the file, save it to disk, instead, and run the file from your disk.

The Log Server installation screen appears:

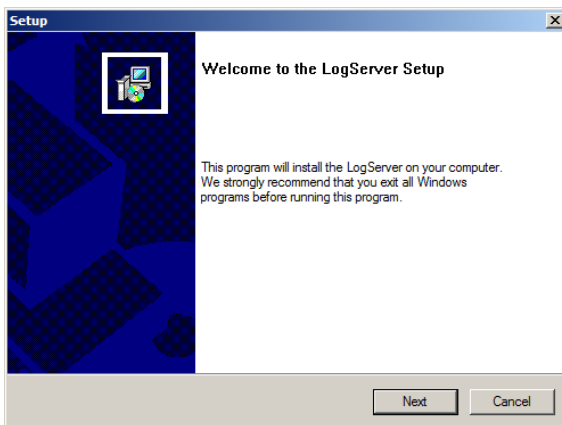

4. Click **Next**. Then follow the on-screen instructions to complete the installation and have the Log Server program icon placed on your desktop.

Starting Up

To start the Log Server, either double click the program icon, or key in the full path to the program on the command line. The first time you run it, a screen similar to the one below appears:

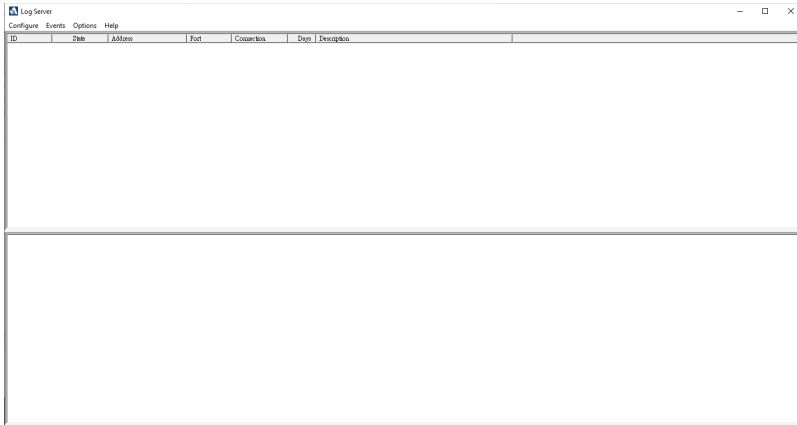

-
- Note:**
1. The MAC address of the Log Server computer must be specified in the *ANMS* settings.
 2. The Log Server requires the Microsoft Jet OLEDB 4.0 driver- if the program doesn't start.
-

The screen is divided into three components:

- ◆ A *Menu Bar* at the top
- ◆ A panel that will contain a list of Matrix KVM switches in the middle.
- ◆ A panel that will contain an *Events List* at the bottom

Each of the components is explained in the sections that follow.

The Menu Bar

The Menu bar consists of four items:

- ◆ Configure
- ◆ Events
- ◆ Options
- ◆ Help

These are discussed in the sections that follow.

Note: If the Menu Bar appears to be disabled, click in the List window to enable it.

Configure

The Configure menu contains three items: Add; Edit; and Delete. They are used to add new units to the List; edit the information for units already on the list; or delete units from the list.

- ◆ To add a unit to the list, click **Add**.
- ◆ To edit or delete a listed unit, first select the target in the List window, then open this menu and click **Edit** or **Delete**.

When you choose *Add* or *Edit*, a dialog box, similar to the one below, appears:

Add a Server [X]

Address:

Port:

Enable username/password authentication

Username:

Password:

Description:

Limit: Days

Enable automatic export for every Days

Save to:

A description of the fields is given in the table, below:

Field	Explanation
Address	This can either be the IP address of the computer the Log Server is running on, or its DNS name.
Port	The port number that was assigned to the Log Server under <i>Device Management</i> .
Enable username/ password authentication	Check this box to enable username and password authentication, and fill in the required fields.
Description	This field is provided so that you can put in a descriptive reference for the unit to help identify it.
Limit	This specifies the number of days that an event should be kept in the Log Server's database. Events that exceed the amount of time specified here can be removed with the Maintenance function.
Enable automatic export for every	Check this box and enter the number of Days to pass before the log server automatically exports a log file. Click Browser to select the directory where you want the log file saved to.

Fill in or modify the fields, then click **OK** to finish.

Events

The Events Menu has two items: *Search* and *Maintenance*.

Search:

Search allows you to search for events containing specific words or strings.

When you access this function, a screen, similar to the one below, appears:

A description of the items is given in the table, below:

Item	Description
New search	This is one of three radio buttons that define the scope of the search. If it is selected, the search is performed on all the events in the database for the selected unit.
Search last results	This is a secondary search performed on the events that resulted from the previous search.
Search excluding last results	This is a secondary search performed on all the events in the database for the selected unit excluding the events that resulted from the previous search.

Item	Description
Server List	Matrix KVM switches are listed according to their IP address. Select the unit that you want to perform the search on from this list. You can select more than one unit for the search. If no units are selected, the search is performed on all of them.
Priority	Sets the level for how detailed the search results display should be. <i>Least</i> is the most general; <i>Most</i> is the most specific. Least results appear in black; Less results appear in blue; Most results appear in red.
Start Date	Select the date that you want the search to start from. The format follows the YYYY/MM/DD convention, as follows: 2009/11/04
Start Time	Select the time that you want the search to start from. The format follows the HH:MM:SS convention.
End Date	Select the date that you want the search to end at.
End Time	Select the time that you want the search to end at.
Pattern	Key in the pattern that you are searching for here. The multiple character wildcard (%) is supported. E.g., h%ds would match hands and hoods.
Results	Lists the events that contained matches for the search.
Search	Click this button to start the search.
Print	Click this button to print the search results.
Export	Click this button to save the search results to file.
Exit	Click this button to exit the Log Server.

Maintenance:

This function allows the administrator to perform manual maintenance of the database, such as erasing specified records before their expiration time is up.

Options

Network Retry allows you to set the number of seconds that the Log Server should wait before attempting to connect if its previous attempt to connect failed. When you click this item, a dialog box similar to the one below, appears:

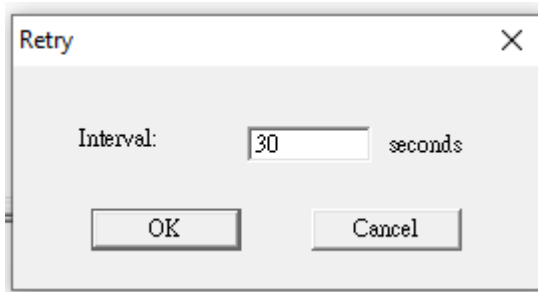

Key in the number of seconds, then click **OK** to finish.

Help

From the Help menu, click Contents to access the online Windows Help file. The help file contains instructions about how to setup, operation and troubleshoot the Log Server.

The Log Server Main Screen

Overview

The Log Server Main Screen is divided into two main panels.

- ◆ The upper (List) panel lists all of the units that have been selected for the Log Server to track.
- ◆ The lower (Event) panel displays the tick information for the currently selected unit. (If there are more than one unit, the selected unit is the one that is highlighted).
- ◆ To select a unit in the list, simply click on it.

The List Panel

The List panel contains six fields:

Field	Explanation
ID	Provides the list of devices which have been added to the log server. Use the checkbox to select devices for which you want to view logs.
State	Displays whether the Log Server records the ticks for this unit, or not. If the ID checkbox is checked, the field displays <i>Recording</i> , and the ticks are recorded. If the ID checkbox is not checked, the field displays <i>Paused</i> , and the ticks are not recorded. Note: Even though a unit is not currently the one selected, if its ID checkbox is checked, the Log Server will still record its ticks.
Address	This is the IP Address or DNS name that was given to the unit when it was added to the Log Server.
Port	This is the Access Port number assigned to the unit.
Connection	<ul style="list-style-type: none"> ◆ If the Log Server is connected to the unit, this field displays <i>Connected</i>. ◆ If the Log Server is not connected, this field displays <i>Waiting</i>. This means that the Log Server's MAC address has not been set properly. It needs to be set on the <i>Device Management Date/Time</i> page.
Days	This field displays the number of days that the unit's log events are to be kept in the Log Server's database before expiration.

Field	Explanation
Description	This field displays the descriptive information given for the unit when it was added to the Log Server.

The Event Panel









The lower panel displays log events for the currently selected unit. Note that if there are more than one units, even though they aren't currently selected, if their *Recording* checkbox is checked, the Log Server records their log events and keeps them in its database.

Chapter 17

Keyboard Emulation

Mac Keyboard







The PC compatible (101/104 key) keyboard can emulate the functions of the Mac keyboard. The emulation mappings are listed in the table below.

PC Keyboard	Mac Keyboard
[Shift]	Shift
[Ctrl]	Ctrl
	
[Ctrl] [1]	
[Ctrl] [2]	
[Ctrl] [3]	
[Ctrl] [4]	
[Alt]	Alt
[Print Screen]	F13
[Scroll Lock]	F14
	=
[Enter]	Return
[Backspace]	Delete
[Insert]	Help
[Ctrl] 	F15

Note: When using key combinations, press and release the first key (Ctrl), then press and release the activation key.

Sun Keyboard

The PC compatible (101/104 key) keyboard can emulate the functions of the Sun keyboard when the control key [Ctrl] is used in conjunction with other keys. The corresponding functions are shown in the table below.

PC Keyboard	Sun Keyboard
[Ctrl] [T]	Stop
[Ctrl] [F2]	Again
[Ctrl] [F3]	Props
[Ctrl] [F4]	Undo
[Ctrl] [F5]	Front
[Ctrl] [F6]	Copy
[Ctrl] [F7]	Open
[Ctrl] [F8]	Paste
[Ctrl] [F9]	Find
[Ctrl] [F10]	Cut
[Ctrl] [1]	
[Ctrl] [2]	
[Ctrl] [3]	
[Ctrl] [4]	
[Ctrl] [H]	Help
	Compose
	

Note: When using key combinations, press and release the first key (Ctrl), then press and release the activation key.

Chapter 18

The Firmware Upgrade Utility

Introduction (CL3708 / CL3716 Only)

The purpose of the Windows-based Firmware Upgrade Utility is to provide an automated process for upgrading all CL3708 / CL3716 switches in an installation. The program comes as part of a Firmware Upgrade Package that is specific for each device.

As new firmware versions become available, new firmware upgrade packages are posted on our website. Check the website regularly to find the latest information and packages.

Downloading the Firmware Upgrade Package

To download the firmware upgrade package:

1. From a computer that is not part of your KVM installation go to our ATEN website and choose the model name that relates to your device. A list of available firmware upgrade packages appears.
2. Choose the firmware upgrade package that you wish to install (usually the most recent) and download it to your computer.

Preparation

To prepare for the firmware upgrade, do the following:

1. Use the *firmware upgrade cable* provided with this unit to connect a COM port via an ATEN UC232A USB to RS-232 Adapter on your computer to the *firmware upgrade port* of your CL3708 / CL3716. Please contact your ATEN deal for UC232A product information.

Note: Slide your firmware upgrade switch to Normal position for upgrade.

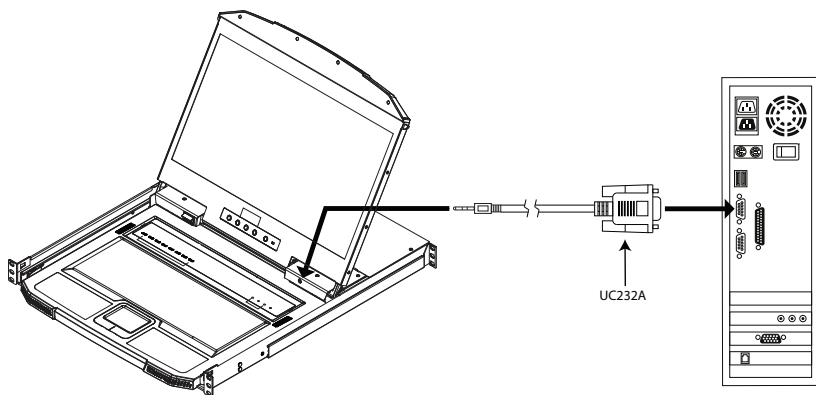

2. Shut down all the computers on the KVM installation.
3. From your KVM switch console, login to the OSD as the administrator (see page 31) and select the **F4 ADM** function.
4. Scroll down to FIRMWARE UPGRADE. Press **[Enter]**, then press **[Y]** to invoke *Firmware Upgrade Mode* (see page 41)

Starting the Upgrade

To upgrade the firmware:

1. Run the downloaded firmware upgrade package file either by double-clicking the file icon, or by opening a command line and entering the full path to it.

The *Firmware Upgrade Utility* welcome screen appears:

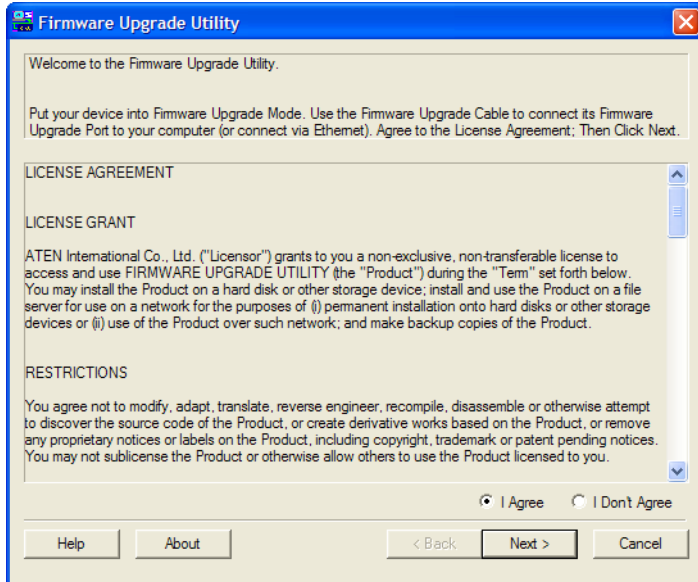

Note: The screens shown in this section are for reference only. The wording and layout of the actual screens put up by the Firmware Upgrade Utility may vary slightly from these examples.

2. Read and *Agree* to the License Agreement (enable the I Agree radio button).
3. Click **Next** to continue. The *Firmware Upgrade Utility* main screen appears. The devices capable of being upgraded are listed in the *Device List* panel:

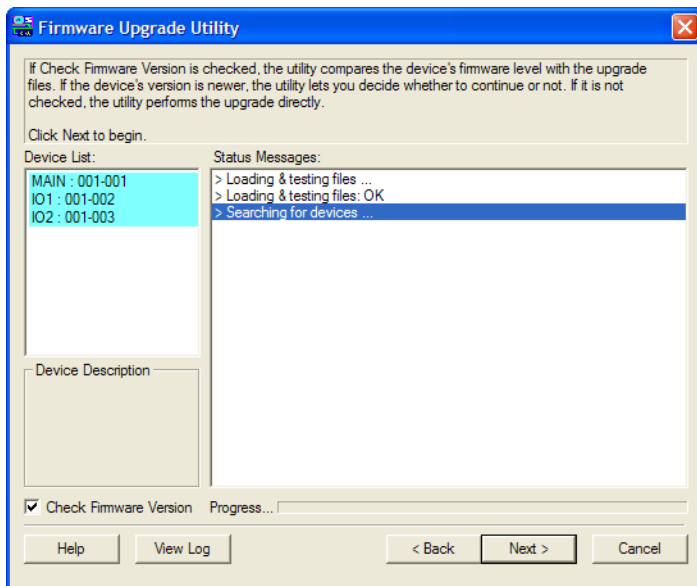

4. Click **Next** to perform the upgrade.

If you enabled *Check Firmware Version*, the Utility compares the device's firmware level with that of the upgrade files. If it finds that the device's version is higher than the upgrade version, it brings up a dialog box informing you of the situation and gives you the option to continue or cancel.

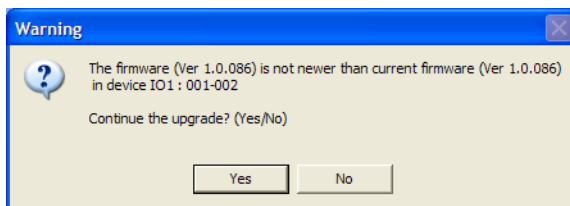

If you didn't enable *Check Firmware Version*, the Utility installs the upgrade files without checking whether they are a higher level, or not.

As the upgrade proceeds, status messages appear in the *Status Messages* panel, and the progress toward completion is shown on the *Progress* bar.

Upgrade Succeeded

After the upgrade has completed, a screen appears to inform you that the procedure was successful.

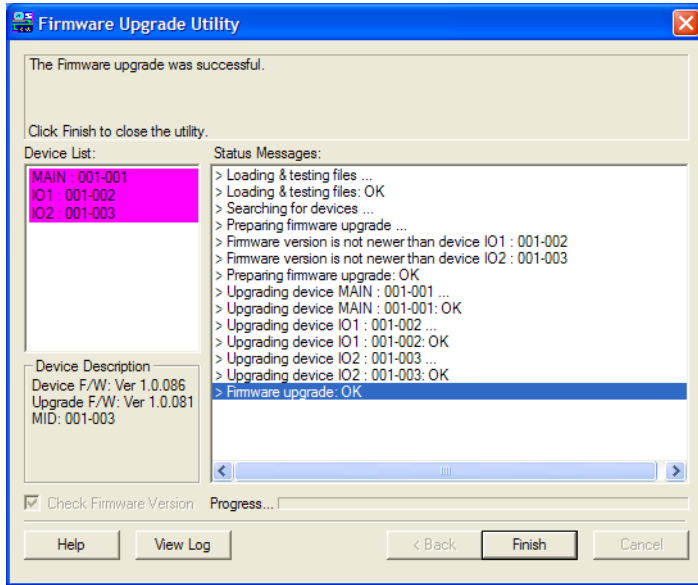

Click **Finish** to close the *Firmware Upgrade Utility*.

Upgrade Failed

If the firmware upgrade fails (*Upgrade Succeeded* screen does not appear), you can recover the situation.

Possible reasons for firmware upgrade failure are:

- ◆ When a firmware upgrade was manually aborted.
- ◆ When the unit's firmware becomes corrupted for some reason and you are unable to operate it.
- ◆ When a firmware upgrade procedure is interrupted.
- ◆ When a firmware upgrade procedure fails.

To recover a failed firmware upgrade, do the following:

1. Power off the unit.
2. Connect the *firmware upgrade cable* to its *firmware upgrade port*.
3. Slide the *firmware upgrade switch* to the **Recover** position.
4. Power the unit back on and repeat the upgrade procedure (see *Starting the Upgrade* on page 229).
5. After the unit has been successfully upgraded, power it off, and slide the *firmware upgrade switch* back to the **Normal** position.
6. Power the unit back on again.

Safety Instructions

General

- ◆ This product is for indoor use only.
- ◆ Read all of these instructions. Save them for future reference.
- ◆ Follow all warnings and instructions marked on the device.
- ◆ Do not place the device on any unstable surface (cart, stand, table, etc.). If the device falls, serious damage will result.
- ◆ Do not use the device near water.
- ◆ Do not place the device near, or over, radiators or heat registers.
- ◆ The device cabinet is provided with slots and openings to allow for adequate ventilation. To ensure reliable operation, and to protect against overheating, these openings must never be blocked or covered.
- ◆ The device should never be placed on a soft surface (bed, sofa, rug, etc.) as this will block its ventilation openings. Likewise, the device should not be placed in a built in enclosure unless adequate ventilation has been provided.
- ◆ Never spill liquid of any kind on the device.
- ◆ Unplug the device from the wall outlet before cleaning. Do not use liquid or aerosol cleaners. Use a damp cloth for cleaning.
- ◆ The device should be operated from the type of power source indicated on the marking label. If you are not sure of the type of power available, consult your dealer or local power company.
- ◆ The device is designed for IT power distribution systems with 230V phase-to-phase voltage.
- ◆ To prevent damage to your installation it is important that all devices are properly grounded.
- ◆ The device is equipped with a 3-wire grounding type plug. This is a safety feature. If you are unable to insert the plug into the outlet, contact your electrician to replace your obsolete outlet. Do not attempt to defeat the purpose of the grounding-type plug. Always follow your local/national wiring codes.

- ◆ Do not allow anything to rest on the power cord or cables. Route the power cord and cables so that they cannot be stepped on or tripped over.
- ◆ If an extension cord is used with this device make sure that the total of the ampere ratings of all products used on this cord does not exceed the extension cord ampere rating. Make sure that the total of all products plugged into the wall outlet does not exceed 15 amperes.
- ◆ To help protect your system from sudden, transient increases and decreases in electrical power, use a surge suppressor, line conditioner, or un-interruptible power supply (UPS).
- ◆ Position system cables and power cables carefully; Be sure that nothing rests on any cables.
- ◆ Never push objects of any kind into or through cabinet slots. They may touch dangerous voltage points or short out parts resulting in a risk of fire or electrical shock.
- ◆ Do not attempt to service the device yourself. Refer all servicing to qualified service personnel.
- ◆ If the following conditions occur, unplug the device from the wall outlet and bring it to qualified service personnel for repair.
 - ◆ The power cord or plug has become damaged or frayed.
 - ◆ Liquid has been spilled into the device.
 - ◆ The device has been exposed to rain or water.
 - ◆ The device has been dropped, or the cabinet has been damaged.
 - ◆ The device exhibits a distinct change in performance, indicating a need for service.
 - ◆ The device does not operate normally when the operating instructions are followed.
- ◆ Only adjust those controls that are covered in the operating instructions. Improper adjustment of other controls may result in damage that will require extensive work by a qualified technician to repair.
- ◆ Avoid circuit overloads. Before connecting equipment to a circuit, know the power supply's limit and never exceed it. Always review the electrical specifications of a circuit to ensure that you are not creating a dangerous condition or that one doesn't already exist. Circuit overloads can cause a fire and destroy equipment.

Rack Mounting

- ◆ Before working on the rack, make sure that the stabilizers are secured to the rack, extended to the floor, and that the full weight of the rack rests on the floor. Install front and side stabilizers on a single rack or front stabilizers for joined multiple racks before working on the rack.
- ◆ Always load the rack from the bottom up, and load the heaviest item in the rack first.
- ◆ Make sure that the rack is level and stable before extending a device from the rack.
- ◆ Do not overload the AC supply branch circuit that provides power to the rack. The total rack load should not exceed 80 percent of the branch circuit rating.
- ◆ Make sure that all equipment used on the rack – including power strips and other electrical connectors – is properly grounded.
- ◆ Ensure that proper airflow is provided to devices in the rack.
- ◆ Ensure that the operating ambient temperature of the rack environment does not exceed the maximum ambient temperature specified for the equipment by the manufacturer
- ◆ Do not step on or stand on any device when servicing other devices in a rack.
- ◆ **Caution:** Slide/rail (LCD KVM) mounted equipment is not to be used as a shelf or a work space.



Technical Support

International

- ◆ For online technical support – including troubleshooting, documentation, and software updates: <http://support.aten.com>
- ◆ For telephone support, see *Telephone Support*, page iv:

North America

Email Support		support@aten-usa.com
Online Technical Support	Troubleshooting	http://www.aten-usa.com/ support
	Documentation	
	Software Updates	
Telephone Support		1-888-999-ATEN ext 4988 1-949-428-1111

When you contact us, please have the following information ready beforehand:

- ◆ Product model number, serial number, and date of purchase.
- ◆ Your computer configuration, including operating system, revision level, expansion cards, and software.
- ◆ Any error messages displayed at the time the error occurred.
- ◆ The sequence of operations that led up to the error.
- ◆ Any other information you feel may be of help.

Specifications

CL3708

Function		CL3708NW	CL3708NX
Computer Connections	Direct	8	
	Max.	128 (via cascade)	
Port Selection		OSD, Hotkey, Pushbutton	
Connectors	KVM Ports	8 x HDMI Female 8 x USB Type-B Female	
	Firmware Upgrade	1 x 3.5 mm Audio Jack Female (Black)	
	Power	1 x IEC 60320/C14	
	External Mouse Port	1 x USB Type-A Female (Front)	
	External Console Ports	1 x HDMI Female 2 x USB Type-A Female	
Switches	Port Selection	8 x Pushbuttons	
	Rest	1 x Semi-recessed Pushbutton	
	Firmware Upgrade	1 x Slide Switch	
	Power	1 x Rocker Switch	
	LCD Control	4 x Pushbuttons	
	LCD Power	1 x LED Pushbutton	
LEDs	Online	8 (Orange)	
	Selected	8 (Green)	
	Power	1 x KVM Console (Dark Green) 1 x LCD (Orange)	
	Lock	1 x Num Lock (Green) 1 x Caps Lock (Green) 1 x Scroll Lock (Green)	
	LED Illumination Light	1 x LED Illumination Light	

Function		CL3708NW	CL3708NX
Panel Specs	LCD Module	18.5" TFT-LCD	
	Resolution	1920 x 1080 @60 Hz	1366 x 768 @ 60 Hz
	Response Time	20 ms	5 ms
	Viewing Angle	178° (H), 178° (V)	170° (H), 160° (V)
	Pixel Pitch	0.213 mm x 0.213 mm	0.3 mm x 0.3 mm
	Supported Color	16.77M colors	16.77 M Colors
	Contrast Ratio	1000:1	
	Luminance	350 cd/m ²	450 cd/m ²
Video	Input Video Resolution	up to 1920 x 1200 @ 60Hz; 1920 x 1080 @ 60 Hz, DDC2B	Up to 1920 x 1200 @ 60 Hz; 1366 x 768 @ 60Hz
	Second Console	1920 x 1200 @ 60 Hz	1920 x 1200 @ 60 Hz
Scan Interval		1–255 secs	
Emulation	Keyboard / Mouse	USB	
Maximum Input Power Rating		100-240V AC; 50-60 Hz; 1 A	
Power Consumption		AC110V:25.5W:126BTU/h AC220V:26.1W:129BTU/h	

Note:

- ◆ The measurement in Watts indicates the typical power consumption of the device with no external loading.
- ◆ The measurement in BTU/h indicates the power consumption of the device when it is fully loaded.

Environmental	Operating Temp.	0 – 40 °C
	Storage Temp	-20 – 60 °C
	Humidity	0–80% RH, Non-condensing
Physical Properties	Housing	Metal + Plastic
	Rail Type	Single Rail
	Weight	10.59 kg (23.33 lb)
	Dimensions (L x W x H)	48.06 x 63.10 x 4.28 cm (18.92 x 24.84 x 1.69 in)
	Body Dimensions (L x W x H)	44.92 x 58.4 x 4.28 cm (17.69 x 22.99 x 1.69 in)
	Note: The specified body dimensions do not include the dimensions of the I/O ports, handles, and mounting brackets.	

CL3716

Function		CL3716NW	CL3716NX
Computer Connections	Direct	16	
	Max.	256 (via cascade)	
Port Selection		OSD, Hotkey, Pushbutton	
Connectors	KVM Ports	16 x HDMI Female 16 x USB Type-B Female	
	Firmware Upgrade	1 x 3.5 mm Audio Jack Female (Black)	
	Power	1 x IEC 60320/C14	
	External Mouse Port	1 x USB Type-A Female (Front)	
	External Console Ports	1 x HDMI Female 2 x USB Type-A Female	
Switches	Port Selection	16 x Pushbuttons	
	Rest	1 x Semi-recessed Pushbutton	
	Firmware Upgrade	1 x Slide Switch	
	Power	1 x Rocker Switch	
	LCD Control	4 x Pushbuttons	
	LCD Power	1 x LED Pushbutton	
LEDs	Online	16 (Orange)	
	Selected	16 (Green)	
	Power	1 x KVM Console (Dark Green) 1 x LCD (Orange)	
	Lock	1 x Num Lock (Green) 1 x Caps Lock (Green) 1 x Scroll Lock (Green)	
	LED Illumination Light	1 x LED Illumination Light	
Panel Specs	LCD Module	18.5" TFT-LCD	
	Resolution	1920 x 1080 @60 Hz	1366 x 768 @ 60 Hz
	Response Time	20 ms	5 ms
	Viewing Angle	178° (H), 178° (V)	170° (H), 160° (V)
	Pixel Pitch	0.213 mm x 0.213 mm	0.3 mm x 0.3 mm
	Supported Color	16.77M colors	16.77 M Colors
	Contrast Ratio	1000:1	
	Luminance	350 cd/m ²	450 cd/m ²

Function		CL3716NW	CL3716NX
Video	Input Video Resolution	up to 1920 x 1200 @ 60Hz; 1920 x 1080 @ 60 Hz, DDC2B	Up to 1920 x 1200 @ 60 Hz; 1366 x 768 @ 60Hz
	Second Console	1920 x 1200 @ 60 Hz	1920 x 1200 @ 60 Hz
Scan Interval		1–255 secs	
Emulation	Keyboard / Mouse	USB	
Maximum Input Power Rating		100-240V AC; 50-60 Hz; 1 A	
Power Consumption		AC110V:25.5W:126BTU/h AC220V:26.1W:129BTU/h	

Note:

- ◆ The measurement in Watts indicates the typical power consumption of the device with no external loading.
- ◆ The measurement in BTU/h indicates the power consumption of the device when it is fully loaded.

Environmental	Operating Temp.	0 – 40 °C
	Storage Temp	-20 – 60 °C
	Humidity	0–80% RH, Non-condensing
Physical Properties	Housing	Metal + Plastic
	Rail Type	Single Rail
	Weight	10.59 kg (23.33 lb)
	Dimensions (L x W x H)	48.06 x 63.10 x 4.28 cm (18.92 x 24.84 x 1.69 in)
	Body Dimensions (L x W x H)	44.92 x 58.4 x 4.28 cm (17.69 x 22.99 x 1.69 in)
	Note: The specified body dimensions do not include the dimensions of the I/O ports, handles, and mounting brackets.	

CL3708iNW / CL3716iNW

Function		CL3708iNW	CL3716iNW
Computer Connections	Direct	8	16
	Max.	8	16
Port Selection		OSD, Hotkey, Pushbutton	
Connectors	KVM Ports	8 x HDMI Female 8 x USB Type-B Female	16 x HDMI Female 16 x USB Type-B Female
	Firmware Upgrade	1 x 3.5 mm Audio Jack Female (Black)	
	Power	1 x IEC 60320/C14	
	External Mouse Port	1 x USB Type-A Female (Front)	
	External Console Ports	1 x HDMI Female 2 x USB Type-A Female	
	LAN Port	1 x RJ-45 Female	
Switches	Port Selection	8 x Pushbuttons	16 x Pushbuttons
	Rest	1 x Semi-recessed Pushbutton	
	Firmware Upgrade	1 x Slide Switch	
	Power	1 x Rocker Switch	
	LCD Control	4 x Pushbuttons	
	LCD Power	1 x LED Pushbutton	
LEDs	Online	8 (Orange)	16 (Orange)
	Selected	8 (Green)	16 (Green)
	Power	1 x KVM Console (Dark Green) 1 x LCD (Orange)	
	Lock	1 x Num Lock (Green) 1 x Caps Lock (Green) 1 x Scroll Lock (Green)	
	LED Illumination Light	1 x LED Illumination Light	

Function		CL3708iNW	CL3716iNW
Panel Spec	LCD Module	18.5" TFT-LCD	
	Resolution	1920 x 1080 @ 60 Hz	
	Response Time	20 ms	
	Viewing Angle	178° (H), 178° (V)	
	Pixel Pitch	0.213 mm x 0.213 mm	
	Supported Color	16.77 M Colors	
	Contrast Ratio	1000 : 1	
	Luminance	350 cd/m ²	
Video	Remote	1920 x 1200 @ 60 Hz	
	Input Video Resolution	Up to 1920 x 1200 @ 60 Hz	
	Second Console	1920 x 1200 @ 60 Hz	
Scan Interval		1–255 secs	
Emulation	Keyboard / Mouse	USB	
Maximum Input Power Rating		100-240V AC; 50-60 Hz; 1 A	
Power Consumption		AC110V:35.2W:171 BTU/h	AC110V:42.1W:20 4BTU/h
		AC220V:35.7W:17 4BTU/h	AC220V:41.7W:20 2BTU/h
		Note: <ul style="list-style-type: none"> ◆ The measurement in Watts indicates the typical power consumption of the device with no external loading. ◆ The measurement in BTU/h indicates the power consumption of the device when it is fully loaded. 	
Environmental	Operating Temp.	0 – 40 °C	
	Storage Temp	-20 – 60 °C	
	Humidity	0–80% RH, Non-condensing	

Function		CL3708iNW	CL3716iNW
Physical Properties	Housing	Metal + Plastic	
	Rail Type	Single Rail	
	Weight	10.96 kg (24.14 lb)	
	Dimensions (L x W x H)	48.06 x 63.10 x 4.28 cm (18.92 x 24.84 x 1.69 in)	
	Body Dimensions (L x W x H)	44.92 x 58.4 x 4.28 cm (17.69 x 22.99 x 1.69 in)	
	Note: The specified body dimensions do not include the dimensions of the I/O ports, handles, and mounting brackets.		

Maximum Number of Controlled Computers

The following tables show the maximum number of computers a CL3708 / CL3716 unit can control when installed with varying numbers of 8-port or 16-port switches.

CL3708

No. of Switches	No. of Controllable Computers	
	8-port Switches	16-port Switches
1	8	8
2	15	23
3	22	38
4	29	53
5	36	68
6	43	83
7	50	98
8	57	113
9	64	128

CL3716

No. of Switches	No. of Controllable Computers	
	8-port Switches	16-port Switches
1	16	16
2	23	31
3	30	46
4	37	61
5	44	76
6	51	91
7	58	106
8	65	121
9	72	136
10	79	151
11	86	166
12	93	181
13	100	196
14	107	211
15	114	226
16	121	241
17	128	256

Clear Login Information

If you are unable to perform an Administrator login (because the Username and Password information has become corrupted or you have forgotten it, for example) you can clear the login information with the following procedure.

Note: Performing this procedure also returns all settings to their defaults.

To clear the login information (and return all settings to their defaults), do the following:

1. Power off the LCD KVM over IP switch and remove its housing.
2. Use a jumper cap to short the mainboard jumper labeled **J19**.
3. Power on the LCD KVM over IP switch.
4. When the front panel LEDs flash, power off the LCD KVM over IP switch.
5. Remove the jumper cap from **J19**.
6. Close the housing and start the LCD KVM over IP switch.

After power on the unit, you can use the default login Username and Password to log in.

Supported KVM Switches

The CL3708 / CL3716 is compatible with a number of ATEN Rack KVM and Cat 5 KVM switches. For a list of compatible models, please refer to the Compatible Products section on the product web page.

OSD Factory Default Settings

The factory default settings are as follows:

Setting	Default
OSD Hotkey	[Scroll Lock] [Scroll Lock]
Port ID Display Position	Upper Left Corner
Port ID Display Duration	3 Seconds
Port ID Display Mode	Port Number plus Port Name
Scan Duration	5 Seconds
Scan-Skip Mode	All
Screen Blanker	0 (Disabled)
Logout Timeout	0 (Disabled)
Beeper	Y (Activated)
Accessible Ports	F (Full) For all Users on all Ports

Troubleshooting

Operation problems can be due to a variety of causes. The first step in solving them is to make sure that all cables are securely attached and seated completely in their sockets.

In addition, updating the product's firmware may solve problems that have been discovered and resolved since the prior version was released. If your product is not running the latest firmware version, we strongly recommend that you upgrade. See *The Firmware Upgrade Utility*, page 227, for upgrade details.

Symptom	Possible Cause	Action
Erratic behavior.	Unit not receiving enough power.	Check that the power adapter that was supplied with the unit is plugged in and functioning properly.

ATEN Warranty Policy

The warranty policy may vary by product category and region of purchase. For details, please visit ATEN's official website, select your purchase counties/regions and then go to the Support Center, or contact your local ATEN sales representative for further assistance.

© Copyright 2026 ATEN® International Co., Ltd.
Released: 27 March 2026 1:58 pm

ATEN and the ATEN logo are registered trademarks of ATEN International Co., Ltd. All rights reserved.
All other brand names and trademarks are the registered property of their respective owners.